



Ultimate supercharged engines

Process to add a ULT supercharged engine in the engine list

&

Monitoring of such engines



Tables of Contents

History	3
FOREWORD	4
1. Process overview.....	5
Time schedule	6
2. Reminder of the main points of the current technical regulations related to ULT supercharged engines (Art. 285 of the Appendix J)	7
3. Paperwork: engine description and engine performance layout	8
a. The engine technical form.....	8
b. The mandatory sensors positioning form	10
c. The engine performance evaluation data	11
i. Performance targets.....	11
ii. Datasheet and engine performance evaluation.....	12
4. Engine performance evaluation test	14
a. Test location	14
b. Planning, timing and schedule	15
c. Electronics installation	15
d. Car preparation	16
e. Fuel	17
f. Costs	18
5. FIA passport.....	19
a. New vehicle or car without FIA technical passport.....	19
b. Modified/ updated vehicle with a FIA technical passport	19
6. Racing and monitoring	20
a. Description of the device	20
b. Availability and costs	20
c. Monitoring of the PBoost.....	21
d. Calculated Max PBoost values.....	23
e. Technical support on the field.....	23
APPENDIX I –LIST OF ULT SUPERCHARGED ENGINES.....	24



History

Date/ Release	Changes
2020/10/01	Creation – 1st release
2020/11/20	(...)
2020/12/30	(...)
2021/01/22	(...)
2021/10/15	(...)
2022/01/20	<ul style="list-style-type: none"> • 3.a – Update of the engine technical form template -> V04b • 3.c – Update of the data sheet -> V. 20.01.2022 • 6.e – Update of the Magneti Marelli PO -> full season V09 • 6.e – Clarification regarding the MM track support charge
2022/04/06	<ul style="list-style-type: none"> • 2.b – Clarification of the maximum cylinder capacity of the engines + minimum associated weight • 3.c.i – Specification of the correction factor formula used for engine performance measurements. • 3.c.ii - Update of the curves list & datasheet • 4.a&b – Update of Test location • 4.b – Update of the references to the dbc. File (CC_2020_v4.6) + FIA Datalogger kit User Guide • 4.f – Contact details for invoicing • 6.a - Update of the FIA Datalogger kit User Guide (v1.8) • 6.e – Update of the Magneti Marelli Purchase Order form ver10
2022/06/17	<ul style="list-style-type: none"> • 3.a – Update of the engine technical form template -> V20220509
2023/03/20	<ul style="list-style-type: none"> • Various updates related to the eligibility of Diesel engines & list of engine list is now an appendix of this document, and not part of the Sporting Regs anymore • 2 – simplification and update • 3.a – Clarification of the need of a technical inspection, and associated requirements • 3.a – Technical form template V01_20221214 + guide_20221122 • 3.c – Update of the petrol engine reference power curve (–30kW compare to 2022) + Diesel engine reference power curve • 3.c.ii – Datasheet template for Diesel engines v20221013 • 4.a – Precision about dyno test address • 4.c – Suppression of the possibility to install the FIA datalogging kit prior to the test, in FIA facilities • 4.d – Precisions regarding the sealing of the engine used for the dyno test • 5.d – Correction & update • 6.a – Update of the Marelli User Guide: v1.9_20221212 • 6.b – Update of the Marelli PO: ver11 + description of the main changes • 6.c – Update of the PBoost control strategy (For Diesel engines) • 6.d – Update of the definition of the Max Pboost values, depending on the ULT class the engine is installed in • Appendix I – ULT Supercharged Engine List – 20221231 (previously app. VIII of the Sporting Regs)



2023/04/20	<ul style="list-style-type: none"> • 3.a – Precision related to parts needed to measure the intake manifold total volume • Appendix I – ULT Supercharged Engine List – 20230420: Update of the Max PBoost ratios + Lambda minimum value for TOYOTA 2021-002 engine
2023/12/21	<ul style="list-style-type: none"> • 3.b – Upgrade of the Sensor Positioning form -> V20231221 • 3.c.ii – Clarification regarding Lambda values • 3.b – Specification of a minimum time to submit any sensor positioning modification. • 4.d – Specification of a minimum diameter of sealing wire • 6.b – Marelli PO 2024 • 6.b – Update of the 2023 W2RC MLS System Layout: v5 • 6.c – Update of the PBoost strategy control diagram • 6.d – Update of the PBoost monitoring strategy – No PBoost correction f(PBaro) anymore, for all vehicle classes • Appendix I – ULT Supercharged Engine List – 20231221
2024/06/28	<ul style="list-style-type: none"> • Foreword – update/ refresh of the link to the FIABOX folder • 3.a – Update of the engine technical form template -> V02-20240628 • 3.c.ii – Addition of one power curve at Tmanifold = 30°C. • 4.f – Addition of cost penalty in case of test postponement • 6.a – Update of the .dbc file: FIA_CC_v9.dbc • 6.b – Update of the 2024 W2RC MLS System Layout: v6 • App. I – better quality (readable) – no change
2024/08/16	<ul style="list-style-type: none"> • 3.a – Correction of the engine technical form template -> V02-20240808 • 3.c.ii – Correction related to the Injection timing angle • 4.d – Update of the cost of a set of hub adaptors • 6.a - Update of the .dbc file: FIA_CC_v11.dbc • Appendix I – ULT Supercharged Engine List – 20240816

The modifications with respect with to the last published version of this document, are highlighted in blue.

FOREWORD

All files and documents included in this document and related to the ULT turbocharged engines regulations are available from FIABOX thanks to the following link:

<https://fiabox.fia.com/views/public/lienPublic.xhtml?id=8741&hash=ba728461ca8d0ebe9a53b2a2a8db3f6c118643d3>



1. Process overview

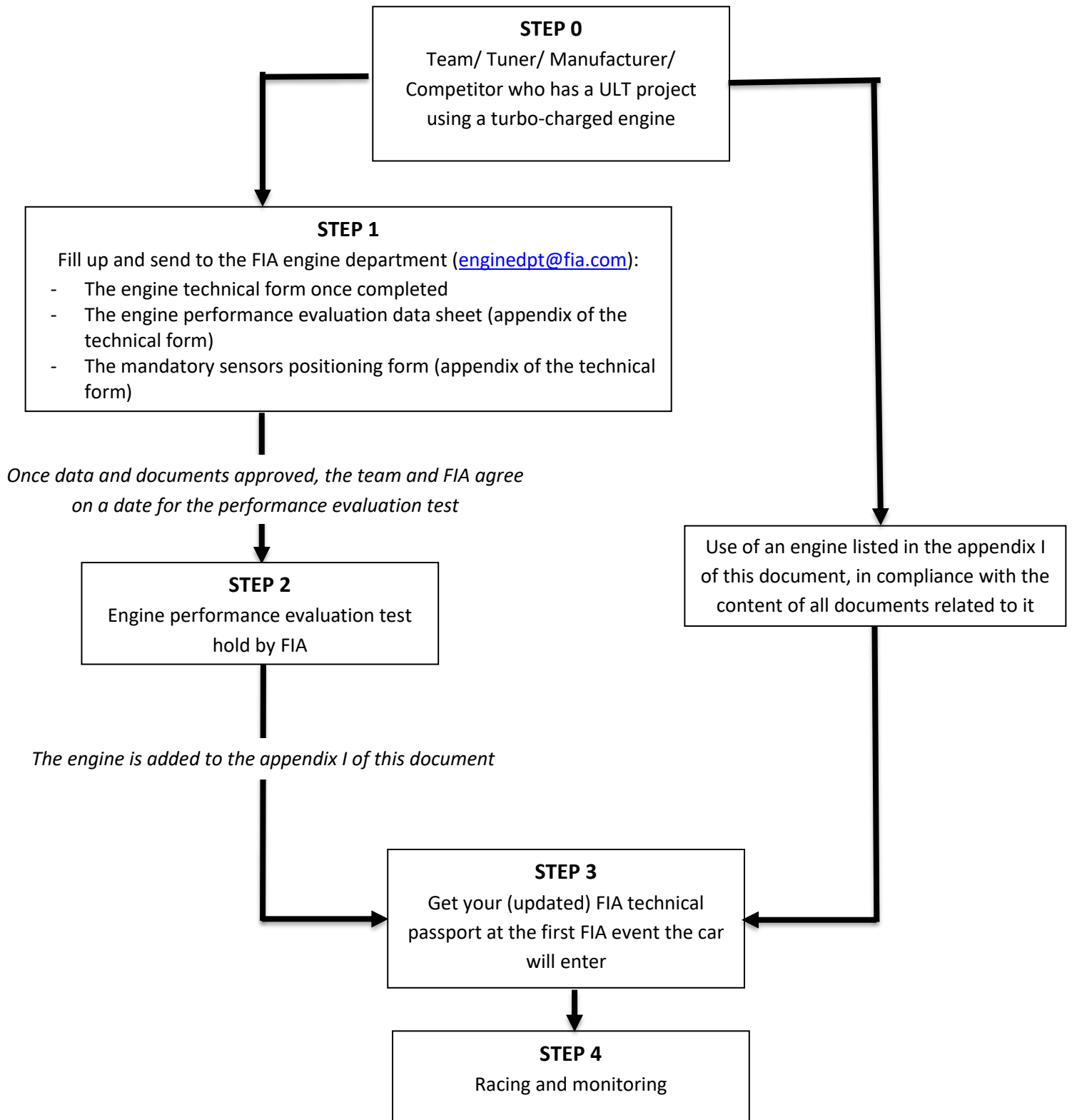



Time schedule

It is strongly recommended to get in touch with the FIA technical department as early as possible.

=> **The following schedule must be respected.**

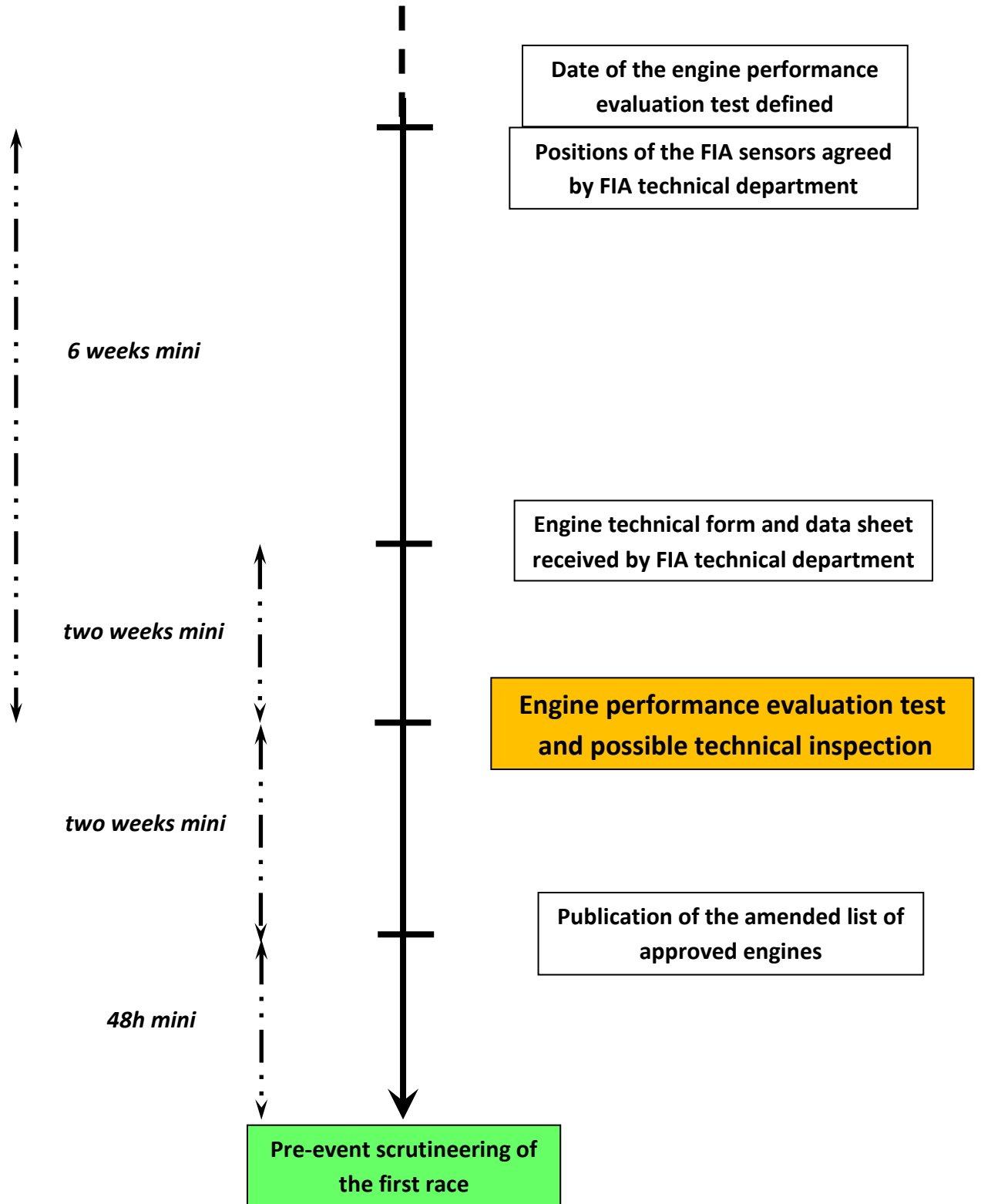



2. Reminder of the main points of the current technical regulations related to ULT supercharged engines (Art. 285 of the Appendix J)

The base engine must derive from the engine of a car able to be homologated in Group A, GT (2012 GT homologation regulations) or T2.

Its maximum cylinder capacity, before application of the multiplication coefficient, is:

- 4000cm³ for petrol engines
- Free for Diesel engines

Most of the parts of the base engine must remain standard; the following parts can be replaced, according to the requirements of the art. 285-5:

- Flywheel
- Conrod shell bearings
- Cylinder head and chain covers
- Valve springs
- Belt(s), chain(s), pulley(s) and pinion(s)
- Spark plugs, generally speaking, looms, ECU & datalogger
- Injectors and injector rail(s)
- Fuel pumps, water pump(s), hydraulic pumps
- Intake manifold
- Exhaust manifold(s)
- Turbocharger(s)
- Lubrication system: oil pump, oil filter housing, radiator, oil/water exchanger, lines, thermostat, sump and pump strainers
- Intercooler(s)
- Water radiator(s), thermostat, fan(s)
- Sensors and actuators

The FIA data logging system must be fitted on the car. It includes the following sensors which have to be fitted in FIA-approved locations:

- Crankshaft position (engine speed rpm)
- Pressure upstream of the intake system
- Temperature upstream of the intake system
- Supercharging pressure
- Temperature inside the intake manifold
- Lambda sensor(s)



Several information must be sent from the ECU to the FIA Datalogger via CAN line, provided the associated sensors are fitted on the car – cf Art. 6.a and the relevant .dbc files.

Performance wise, no turbo restrictor but the following parameters must always comply with the figures specified in the Appendix I of this document:

- Maximum supercharging pressure ratio (to atmospheric pressure)
- Lambda minimum
- Fuel especially if an Advanced Sustainable fuel is used

As specified in the art. 285.5.1.3.4 of the Appendix J, all the vehicles fitted with a turbocharged petrol engine or a turbocharger Diesel engine without restrictor (cf art. 285-5.1.3.3.b) must be fitted with FIA data logging system. See art. 6.

3. Paperwork: engine description and engine performance layout

As first steps of the process, the team/ tuner/ manufacturer or competitor has to provide the following documents and data:

- The engine technical form
- The mandatory sensors positioning form (appendix of the technical form)
- The engine performance evaluation data sheet (appendix of the technical form)

a. The engine technical form

Any engine declaration will be associated to an engine technical form.

The engine technical form will specify all identification references related to the standard base engine and some basic figures and describe all the equipment fitted on it and likely affecting the performance of the engine. They are listed here below:

All equipment fitted on the base engine and likely affecting the performance of the powertrain

- Throttle body(ies)
- Intake manifold(s) – as defined in art. 281-2.3.4
- Intercooler(s) if located in the intake manifold(s)
- Fuel injectors
- Cylinder head cover(s)
- Exhaust manifold(s)
- Turbocharger(s)
- Wastegate actuator(s)
- Exhaust line
- Flywheel
- Sparkplug(s)
- Pressure relief valve if any

All the parts listed here above will be checked during a technical inspection, that will be performed at FIA Valleiry, before or after the engine performance evaluation test.



The team/ tuner/ manufacturer is requested to make all these parts available for this inspection, without dismantling even partly, the engine that will be fitted in the vehicle used for the engine performance evaluation test.

Any useful plates and plugs needed to close the intake manifold parts and indeed measure its volume must also be provided for this inspection.

This engine will be sealed during this test and will be then consider as the reference base standard engine. Seal(s) must not be broken or removed without the approval of the FIA technical department. See art. 4.d.

Thus, the FIA would be able to take the opportunity of a future rebuild of this engine to check it more deeply.

Here is the template of this technical form, and the associated guidelines:

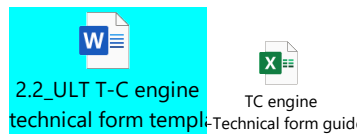



b. The mandatory sensors positioning form

As an appendix of the engine technical form, the team/ tuner/ manufacturer or competitor has to submit for approval the locations of the mandatory sensors.

Thus, the following form has to be filled up and submit:



FIA Sensor
Positioning - CC Bo

No modification is allowed without any preliminary approval of the FIA Technical Department.

Any modification of an already published FIA Sensor Positioning form must be submitted at least 6 weeks prior to the first FIA event the change could be applied.



c. The engine performance evaluation data

i. Performance targets

The FIA engine department has built target engine power curves, respectively for turbocharged petrol and Diesel engines as follows:

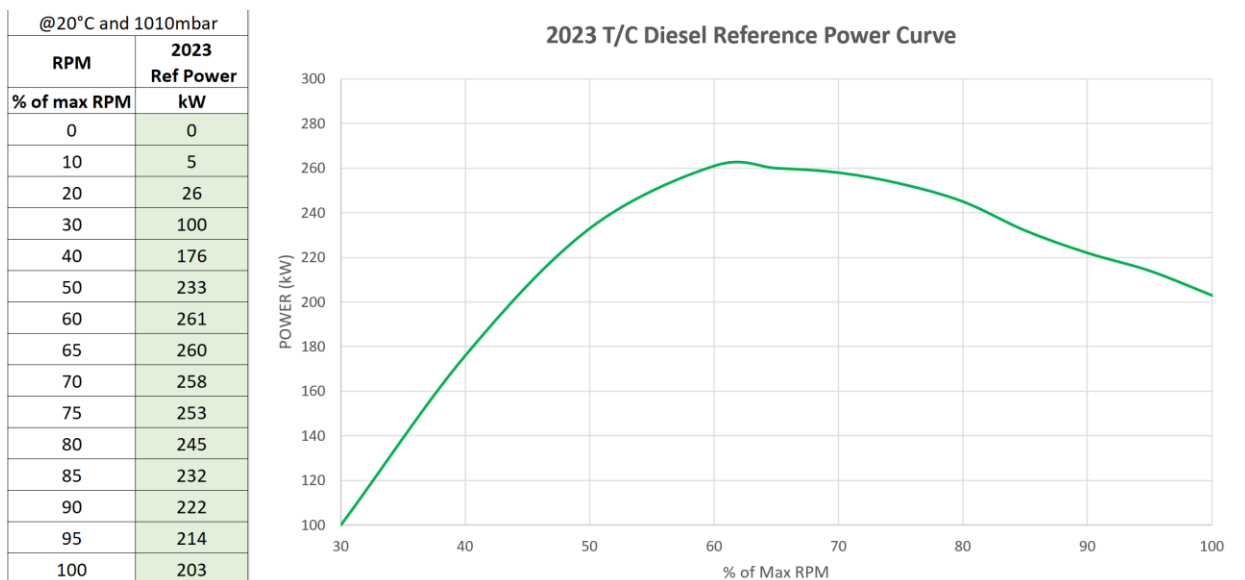
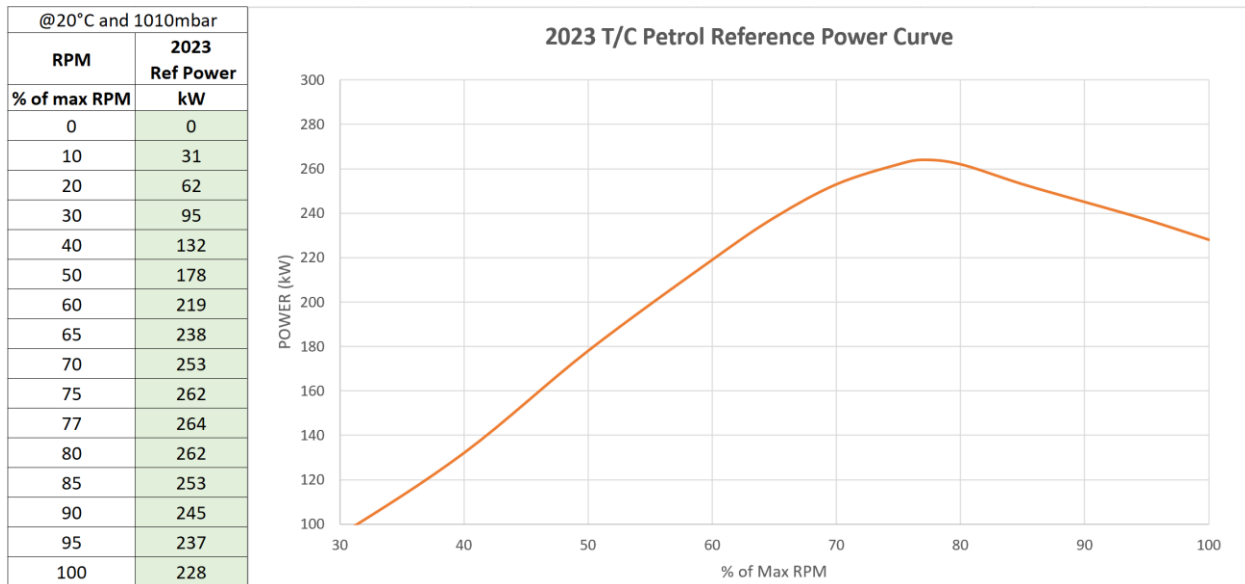

The power is measured at engine output. During the test, the losses (from transmission and rolling) will be measured thanks to a coast down measurement.

The levels of power shown here above have to be considered as a maximum within the measurement conditions set as follows:

- Inlet air temperature: 20°C



- Ambient air pressure: 1010mbar
- Intake manifold air temperature: 50°C
- Water temperature: 90°C

The max rpm level is the one the rev limiter will be set, whatever it is compared with the original/ standard one of the base engine.

Please note that the correction factor to be used during the FIA engine performance measurement process is the following one:

$$FCOT_{TURBO} = \left(\frac{Pref - P_{vap_ref}}{Pref - \left[6,1121 \cdot \exp \left\{ \left(18,678 - \frac{T_{atmo}}{234,5} \right) \cdot \frac{T_{atmo}}{T_{atmo} + 257,14} \right\} \cdot \frac{Hatmo}{100} \right]} \right)^{1,169} \cdot \left(\frac{T_{manifold} + 273}{T_{manifold_ref} + 273} \right)$$

With : Pref = 1010mbar, P_{vap_ref} = 12mbar, and T_{manifold_ref} = 50°C

The fuel used to perform such measurements has to:

- comply with Appendix J Art.252-9.1 (petrol fuel), Art. 252-9.2 (Diesel fuel) or Art. 252-9.3
- If petrol fuel, has a RON level of minimum 101

ii. Datasheet and engine performance evaluation

The team/ tuner/ manufacturer or competitor has to provide the Excel file below, called “datasheet”, dully filled once after the following test bench measurements have carried out:

1. Curve matching FIA requested performance,
2. Curve with PBoost level corresponding to FIA requested performance **-40mbar**,
3. Curve with PBoost level corresponding to FIA requested performance **+40mbar**,
4. Curve with PBoost level corresponding to FIA requested performance **-80mbar**,
5. Curve with PBoost level corresponding to FIA requested performance **+80mbar**,
6. Curve with PBoost level corresponding to FIA requested performance **-120mbar**,
7. Curve matching FIA requested performance, with AirT° intake manifold @ 40° (instead of 50), by adjusting the PBoost compared to the curve at 50°C above.
8. Curve matching FIA requested performance, with AirT° intake manifold @ 30° (instead of 50), by adjusting the PBoost compared to the curve at 50°C above.



Cross-Country Diesel Engine Performance E



Cross-Country Petrol Engine Performance E

All measurements must be performed:

- With the same fuel, that is to say complying with Appendix J Art.252-9.1 or 252-9.2 and/ or 252-9.3,
- With a RON level of minimum 101 (for petrol fuel)
- @ water T° = 90°C
- @ air intake manifold T° = 50°C (except for curves n°7 and n°8)



The setting of all other parameters, especially cam timings, ignition advance angle (petrol engines), injection timing angle (**Diesel Petrol** engines) and Lambda level, is assumed to be the best possible ones.

In other words, any modification of the values of these parameters will lead to a loss of performance.

The Lambda figures have to be considered at full load only (throttle opening allowing to achieve the maximum performance of the engine for a given rpm).

The optimum Lambda level, which will be set for all curves of the data sheet, will be considered as the minimum one afterwards. It is understood that this level corresponds to stationary values, and that in dynamic there may be fluctuations.

Also, the value indicated in the engine list will correspond to the minimum value across the engine speed range.

The same fuel which will have been used to perform these measurements will have to be provided for the FIA engine performance tests.

In the case of the use of an Advanced Sustainable Fuel, compliant with the art. 252-9.3.2, additional measurements using a fuel complying with the art. 252-9.1 with a RON level of minimum 101 may be requested to be performed.

In addition to these curves' measurement figures, we ask you to provide:

- Some basic dimensions of your vehicle
- **All** ignition correction mapping tables (petrol engines)
- **All** injection correction mapping tables (Diesel engines)
- The VVT mapping tables
- The mapping tables of any other actuator that can affect the way the engine could perform.

The data sheet dully filled has to be submitted to the FIA engine department not later than 15 days before the scheduled engine performance evaluation test.

For any further question regarding the datasheet and the associated measurement tests, feel free to write to the following email addresses: enginedpt@fia.com & electronicdpt@fia.com.



4. Engine performance evaluation test

a. Test location

The test will be hold at:

Zone les terres de l'Army
20, impasse des Champs
74350 Allonzier-la-Caille,
FRANCE

Road accesses from:

- South/ Annecy on the right-hand side
- North/ Geneva on the left-hand side.

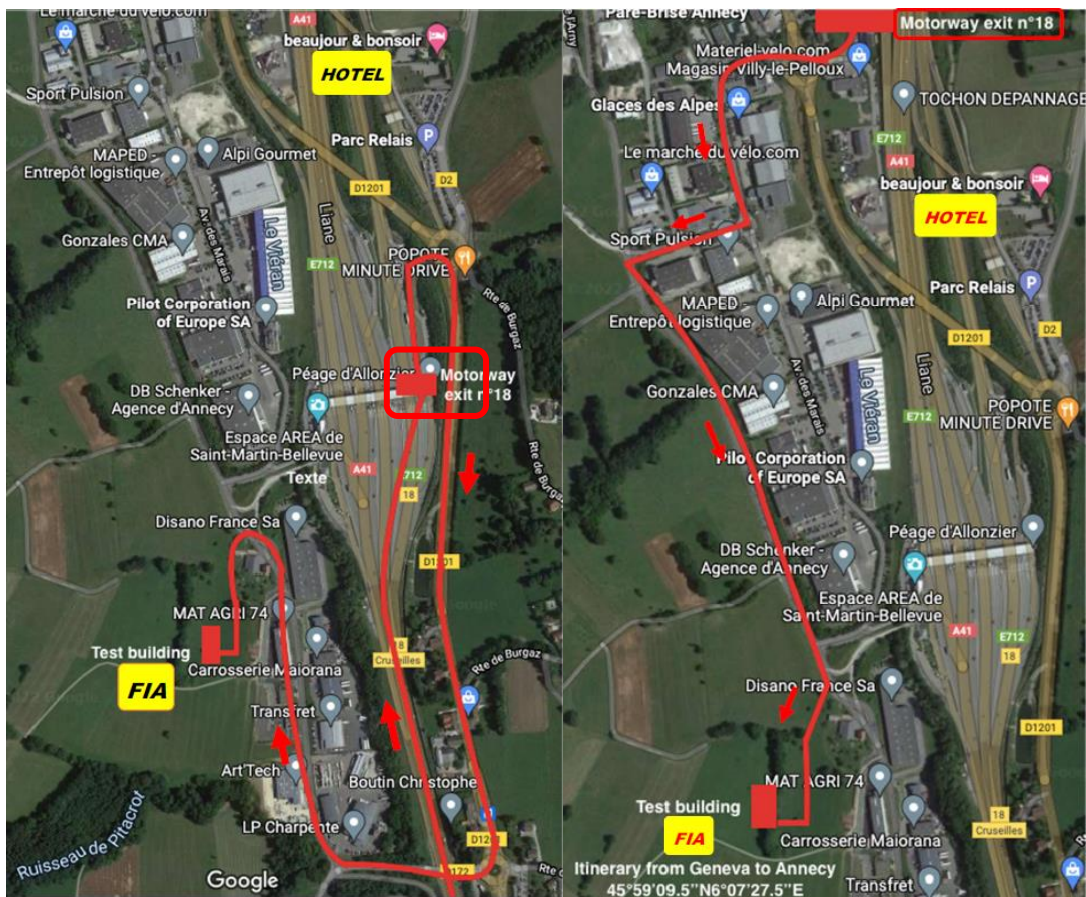

The test will be done in a building that is dedicated for the test. However, please note that this facility is part of a public area.

The trucks will be parked inside the building.



b. Planning, timing and schedule

- The car is expected on site **at 8:00 am latest** in the morning the day of the test.
- It is possible to bring a truck into TRANSFRET facility and to unload the car there. To ensure a smooth operation, thanks for informing us ahead of time on the dimension of the truck.
- If your truck needs to arrive a day earlier, it is possible to park it into TRANSFRET facility or at the FIA site in Valleiry, about 30kms away. You will just have to make sure of the possible opening hours with Daniel Fasano (dfasano-consultant@fia.com)
- We will provide food at midday, so please provide the number of people present at noon at least 7 days before the date of the tests.

c. Electronics installation

A FIA data logger, loom and sensors will have to be installed on the car prior to the test. The content of the FIA data logger kit and the characteristics and dimensions of each component are described in the data logger user guide.

FIA will also collect the channels via the CAN bus from the car ECU, as described in the *FIA_CC_2020_v4.6.dbc* file enclosed in the document *FIA TELEMETRY User Guide_CrossCountry_MLS_v1.9_20221212.doc* enclosed further.



d. Car preparation

- Engine spec:

The engine spec has to be exactly the one described in the engine technical form.

Pboost setups: As it will be requested by FIA, following the analysis of the datasheet.

Before the end of the performance evaluation test, the engine will be sealed by the FIA.

For this purpose, the team/ tuner/ manufacturer is requested to have drilled holes of $\varnothing 2\text{mm}$ in:

- At least 2 screws used to fix the oil sump to the engine block,
- Either 2 bolts to fix each cylinder head cover to each cylinder head, or 1 bolt and the cylinder head,
- All sealing wires must be in place. The diameter of the wire must not be smaller than 0,6mm.

Furthermore, the engine block will be identified using a marking sticker.

The FIA reserve the right to request any additional seal that may be considered useful.

- Bodywork:

We need the car to arrive without any front, rear or lower side bodywork. Ideally with no doors either. Also remove bodywork around the exhaust for side exhausts if any.

The less body parts will be fitted on the car, the easiest and quickest the test will be performed.

- Cooling:

We need to understand the cooling layout of your car. Thus, thanks for providing a few photos of the front of your car (without front bodywork) with arrows indicating location of the coolers.

Thanks for providing and bringing adapters for coolers entry ducts that are not located in front of the car (to fit on a 250mm diameter duct) similar to parts shown hereafter.





- Hub adapters:

We need adapters to be fitted to your hubs in replacement to your wheels.

The drawing of the dyno part that your adapter will have to fit on, can be found hereafter. We ask you to produce these adapters and to bring them at the tests.

Thanks for sharing with us the drawings of your adapters before producing them.

The drawing “for customer” is for info only. These parts will be provided.



MRFLBA01000A - MRFLBA00000A -
for customer.pdf NEUTRAL FLANGE C/

However, a full set of adapters could also be directly ordered for an approximate price of 3000€ w/out VAT (contact: enginedpt@fia.com). It must be ordered not later than 2 weeks before the scheduled test.

- Minimum vertical ride height:

If the vertical distance between the axis of both front and rear hubs and the lowest point of the car is lower than 300mm, the team has to warn the FIA technical department at least 3 weeks before the test date, as wedges will be needed to lift the dynos.

e. Fuel

The fuel(s) to be used for this test has to:

- comply with Appendix J Art.252-9.1 (petrol fuel), Art. 252-9.2 (Diesel fuel) or Art. 252-9.3
- If petrol fuel, has a RON level of minimum 101
- be exactly the one used for the measurements performed to fill the datasheet.

Thus, it has to be provided by the team/ tuner/ manufacturer or competitor together with the filling devices. 120L of each fuel quality, is usually enough to cover all the tests.

Please note that for commodity **it is possible to send the fuel in advance** to the test location. The contact for delivery is : Daniel Fasano, TRANSFRET, Zone les terres de l'Army, **20, impasse des Champs** 74350 ALLONZIER-LA-CAILLE, FRANCE.

NB: before sending the barrels, please ensure the transporter is able to unload his truck alone.

Also, fuel samples for further analysis could be taken at any time during the test.



f. Costs

The cost of the test will be invoiced to the team/ tuner/ manufacturer or competitor.

Thus, you will need to provide us (enginedpt@fia.com) your contact details (table here below) in order to invoice you the costs of the engine performance evaluation tests, together with the possible engine technical inspection.

Company Name	
Legal Address	
VAT Number	
Contact Person	
Email address	
Telephone	

If you need us to mention any Purchase Order number of the final invoice, thanks for providing it within the same time.

Once the date has been booked, any postponement requested by the manufacturer/ team will induce some extra costs following the following rules:

- Total cost will increase by 30% if the FIA is advised between 5 weeks and 2 weeks prior to the initial date of the engine performance evaluation test,
- Total cost will increase by 50% if the FIA is advised less than 2 weeks prior to the initial date of the test.

For any further question regarding the engine performance evaluation tests, feel free to write to the following email addresses: enginedpt@fia.com & electronicdpt@fia.com..

At that point of the process and thanks to the feedback of both the content of the datasheet and the measurements performed during the engine performance evaluation test, the engine as described in the technical form can be added in the appendix I of this document.

In this appendix, the maximum turbo pressure levels $f(\text{rpm})$, defined by the FIA technical department will be specified, together with the Lambda value which will be considered as the minimum value (in full load conditions), and the fuel associated to them if relevant.



5. FIA passport

Depending on the car, 2 possibilities:

a. New vehicle or car without FIA technical passport

The process described in the article 8.3 of the Cross-Country Rally Sporting Regulations has to be followed.

b. Modified/ updated vehicle with a FIA technical passport

The existing technical passport will be updated by the FIA technical delegate at the pre-event scrutineering of the first FIA event the modified car will be entered.

No pre-inspection by an ASN delegate will be needed.

The passport number and the identification stickers will remain on the roll cage.



6. Racing and monitoring

As specified in the art. 285.5.1.3.4 of the Appendix, the monitoring of the performance and the compliance with the working conditions stated in the appendix I of this document will be performed thanks to the FIA data logger together with the mandatory sensors and their associated looms.

a. Description of the device

The Data Logger User Guide here below describes:

- The content of the FIA data logger kit
- The dimensional and technical characteristics of each components
- The way each component has to be installed in the car
- The CAN line specification
- The mandatory CAN Packet data to be published by competitor in the .dbc file v4.6 (also here embedded)

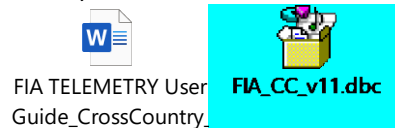

For any question about the datalogger, thanks for writing to the following email address: electronicdpt@fia.com.

b. Availability and costs

The lease conditions of a data logger kits for the FIA events of the Cross-Country World Cup/ Championship will be charged to the team/ competitor.

Each team/ tuner/ manufacturer or competitor who needs a FIA data logger kit, have to send his request to crosscountry@marelli.com, with W2RC-MM@marelli.com and electronicdpt@fia.com in copy, **at least 3 weeks before the date the device is needed** by the team, either for race events or test purpose.

See the PO form to fill up and to be sent as requested.



General lease term and conditions are also specified in there.



Please find here after some remarks and precisions:

- MLS data logger and Marelli main loom, can only be leased, for a single race, together with the rest of the kit, or for a full season
- However, a team/ tuner/ manufacturer or competitor may produce its own dedicated main loom. If so, it must be compliant with the following layout and can't be used before the prior agreement of the FIA (electronicdpt@fia.com)



2024_W2RC_MLS_System_Layout_v6.xlsx

- All sensors and accessories may be purchased from Marelli

c. Monitoring of the PBoost

The engine performance will be monitored on the behalf of the FIA on FIA Cross Country events. The compliance with the article 285-5.1.3 of the Appendix J, accordingly with the values of max PBoost ratio specified in the appendix I of this document, will be checked at any time thanks to the FIA data logging device.

The way the engine Pboost will be compared to the maximum legal Pboost is described in the algorithm presented here after.

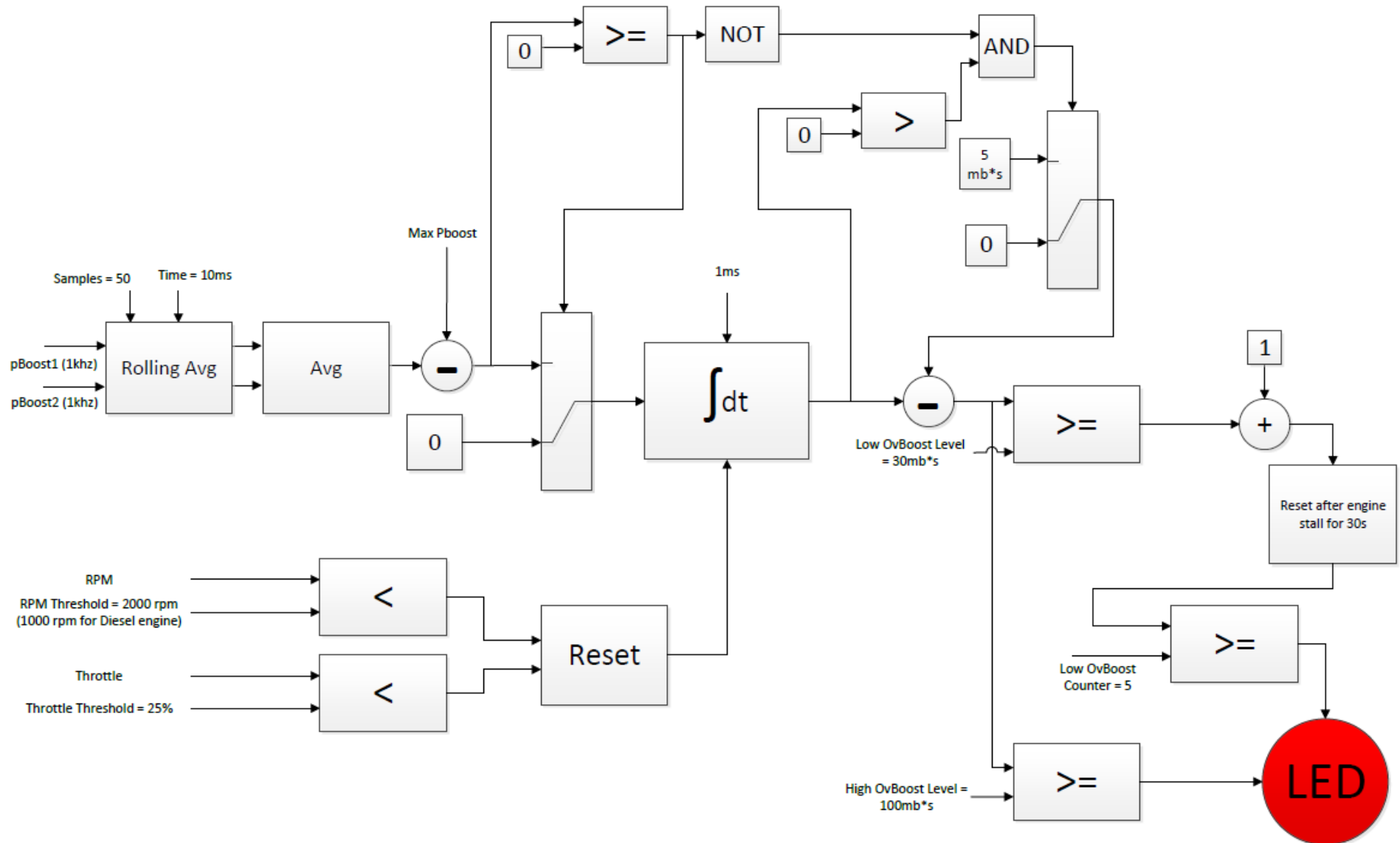

"REMINDERS: Any FIA opinions given above are advisory in nature and do not constitute Technical or Sporting Regulations. All the content of the present document is strictly private & confidential and for the exclusive use of the FIA ."

08/08/2024



d. Calculated Max PBoost values

Whatever the class of the ULT group vehicle is entered, the *Max Pboost* value does not depend on the altitude and barometric pressure and is calculated as follows:

$$\text{Max Pboost(rpm)} = \text{Max PBoost ratio(rpm)} \times 1,010$$

With pressures in bar

e. Technical support on the field

If any, the cost of the track support will be shared in between all the competitors whose the vehicles will be fitted with a FIA datalogger (kit).



APPENDIX I – LIST OF ULT SUPERCHARGED ENGINES

Date of registration of the engine	T/C petrol engine number		Tuner		Base engine				Fuel				Data Sheet					
22/12/2020	2020-001		PRODRIVE		FORD 3.5L GTDI V6 ECOBOOST				Any fuel compliant with Art. 252-9.1				2020-001_252-9.1_20201123					
Engine rpm	2500	2750	3000	3250	3500	3750	4000	4250	4500	4750	5000	5250	5500	5750	6000	6250	6500	
Pboost ratio Max (-) ⁽¹⁾	1,53	1,58	1,63	1,65	1,67	1,68	1,69	1,69	1,68	1,67	1,65	1,59	1,53	1,47	1,42	1,38	1,33	
Declared minimum Lambda	0,93																	
05/10/2021	2020-001		PRODRIVE		FORD 3.5L GTDI V6 ECOBOOST				CORYTON 102RON S90 7.50x				2020-001_CORYTON_20210928					
Engine rpm	2500	2750	3000	3250	3500	3750	4000	4250	4500	4750	5000	5250	5500	5750	6000	6250	6500	
Pboost ratio Max (-) ⁽¹⁾	1,63	1,69	1,76	1,78	1,79	1,79	1,79	1,78	1,78	1,76	1,75	1,68	1,60	1,53	1,47	1,40	1,33	
Declared minimum Lambda	0,93																	
07/04/2023	2021-002		TOYOTA		TOYOTA V35A-FTS				Any fuel compliant with Art. 252-9.1				2020-002_252-9.1_20230919					
Engine rpm	2500	2750	3000	3250	3500	3750	4000	4250	4500	4750	5000	5250	5500	5750	6000	6250	6500	6750
Pboost ratio Max (-) ⁽¹⁾	1,48	1,57	1,67	1,74	1,79	1,82	1,83	1,83	1,83	1,82	1,81	1,78	1,69	1,59	1,49	1,39	1,31	1,27
Declared minimum Lambda	0,88																	
07/04/2023	2021-002		TOYOTA		TOYOTA V35A-FTS				REPSOL RTL_T23707				2020-002_REPSOL RTL_20230919					
Engine rpm	2500	2750	3000	3250	3500	3750	4000	4250	4500	4750	5000	5250	5500	5750	6000	6250	6500	6750
Pboost ratio Max (-) ⁽¹⁾	1,50	1,59	1,70	1,76	1,80	1,82	1,83	1,82	1,81	1,80	1,79	1,76	1,69	1,61	1,52	1,43	1,36	1,32
Declared minimum Lambda	0,88																	
27/10/2021	2021-003		GCK		FORD 3.5L GTDI V6 ECOBOOST				ETS RENEWABLAZE 102 E20 R70				2020-003_ETS RENEWABLAZE_20211224					
Engine rpm	2500	2750	3000	3250	3500	3750	4000	4250	4500	4750	5000	5250	5500	5750	6000	6250	6500	
Pboost ratio Max (-) ⁽¹⁾	1,45	1,51	1,57	1,60	1,64	1,68	1,70	1,72	1,73	1,72	1,71	1,65	1,59	1,54	1,50	1,50	1,49	
Declared minimum Lambda	0,90																	
21/04/2022	2022-004		NWM		FORD 3.5L GTDI V6 ECOBOOST				Any fuel compliant with Art. 252-9.1				2020-004_252-9.1_20231129					
Engine rpm	2500	2750	3000	3250	3500	3750	4000	4250	4500	4750	5000	5250	5500	5750	6000	6250	6500	
Pboost ratio Max (-) ⁽¹⁾	1,56	1,62	1,65	1,66	1,67	1,70	1,74	1,79	1,81	1,77	1,73	1,65	1,56	1,50	1,43	1,37	1,34	
Declared minimum Lambda	0,89																	
19/12/2022	2022-005		BMW MOTOREN GmbH		BMW N57D30 S1				Any fuel compliant with Art. 252-9.2 or HVO fuel				2022-005_252-9.2 & HVO_20221122					
Engine rpm	1500	1750	2000	2250	2500	2750	3000	3250	3500	3750	4000	4250	4500	4750	5000			
Pboost ratio Max (-) ⁽¹⁾	3,10	3,70	4,35	4,35	4,35	4,35	4,28	3,98	3,66	3,37	3,14	2,94	2,80	2,72	2,67			
Declared minimum Lambda	1,06																	
19/12/2022	2022-006		BMW MOTOREN GmbH		BMW N57D30 S1				Any fuel compliant with Art. 252-9.2 or HVO fuel				2022-006_252-9.2 & HVO_20221122					
Engine rpm	1500	1750	2000	2250	2500	2750	3000	3250	3500	3750	4000	4250	4500	4750	5000			
Pboost ratio Max (-) ⁽¹⁾	3,10	3,70	4,35	4,35	4,35	4,35	4,28	3,98	3,66	3,37	3,14	2,94	2,80	2,72	2,67			
Declared minimum Lambda	1,06																	



Date of registration of the engine	T/C petrol engine number		Tuner		Base engine				Fuel				Data Sheet				
21/12/2022	2022-007		Century Racing		Audi/VW V6 2,9 DECA				Any fuel compliant with Art. 252-9.1				2022-007_252-9.1_20221124				
Engine rpm	2500	2750	3000	3250	3500	3750	4000	4250	4500	4750	5000	5250	5500	5750	6000	6250	6500
Pboost ratio Max (-) ⁽¹⁾	1,86	2,01	2,11	2,18	2,22	2,25	2,26	2,27	2,27	2,25	2,21	2,11	2,00	1,91	1,82	1,72	1,65
Declared minimum Lambda		0,89															
Date of registration of the engine	T/C petrol engine number		Tuner		Base engine				Fuel				Data Sheet				
10/10/2023	2023-008		MP SPORT		FORD 3.5L GTDI V6 ECOBOOST				Any fuel compliant with Art. 252-9.1				2023-008_252-9.1_20230920				
Engine rpm	2500	2750	3000	3250	3500	3750	4000	4250	4500	4750	5000	5250	5500	5750	6000	6250	6500
Pboost ratio Max (-) ⁽¹⁾	1,48	1,54	1,58	1,62	1,65	1,68	1,70	1,71	1,72	1,73	1,71	1,63	1,52	1,44	1,39	1,33	1,30
Declared minimum Lambda		0,89															
Date of registration of the engine	T/C petrol engine number		Tuner		Base engine				Fuel				Data Sheet				
08/08/2024	2024-009		OffRoadSport		BMW B58B30B				Any fuel compliant with Art. 252-9.1				2024-009_252-9.1_20240808				
Engine rpm	2500	2750	3000	3250	3500	3750	4000	4250	4500	4750	5000	5250	5500	5750	6000	6250	6500
Pboost ratio Max (-) ⁽¹⁾	1,74	1,80	1,87	1,93	1,99	2,05	2,10	2,16	2,19	2,22	2,22	2,12	2,00	1,90	1,84	1,81	1,79
Declared minimum Lambda		0,88															
Date of registration of the engine	T/C petrol engine number		Tuner		Base engine				Fuel				Data Sheet				
xx/XX/2024	2024-010		BMW MOTORCYC GmbH		BMW S58B30A				Any fuel compliant with Art. 252-9.1				2024-010_252-9.1_20240718				
Engine rpm	2500	2750	3000	3250	3500	3750	4000	4250	4500	4750	5000	5250	5500	5750	6000	6250	6500
Pboost ratio Max (-) ⁽¹⁾	1,71	1,78	1,85	1,88	1,90	1,92	1,96	2,03	2,11	2,16	2,23	2,23	2,09	1,88	1,70	1,61	1,59
Declared minimum Lambda		0,87															
⁽¹⁾ Pboost max (Bar) = PBoost ratio max x 1,010 Bar																	