

**Protrust Solutions Technical
List 16
FK-5-1-12 (Clean Agent)
Installation Manual**



Technical List 16 - Contents

Page 3	System Schematics
Page 4	Bottle Mounting
Page 5	Nozzle Mounting
Page 6	Engine Nozzle Position
Page 7	Cockpit Nozzle Position
Page 8	Activation Installation
Page 9	Electrical Wiring
Page 10	Electrical Circuit Testing
Page 11	Care and Maintenance
Page 12	Spare Parts
Page 13	Location & FAQ

Technical List 16 - Installation Schematics for Mechanical & Electrical

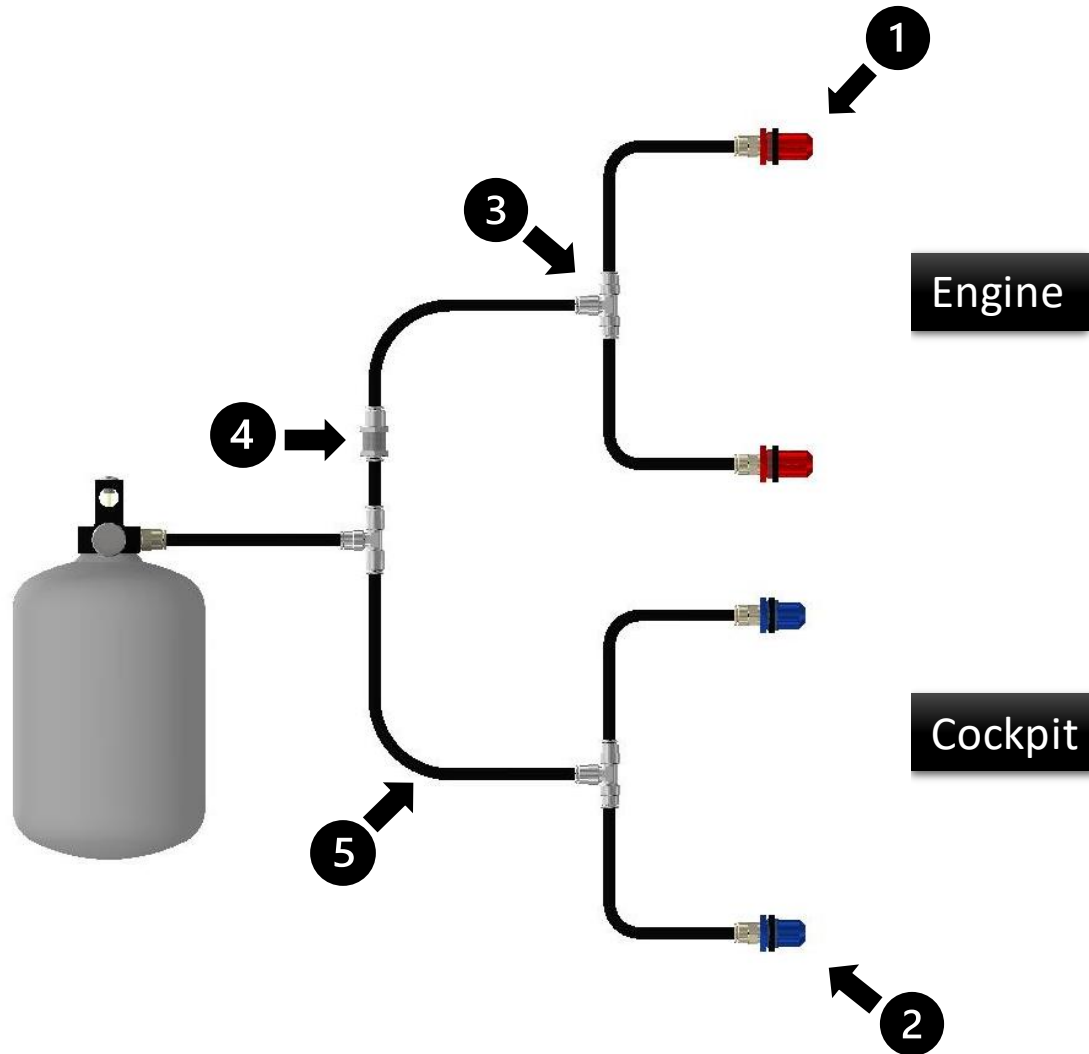

No	Part Number	Description	Qty Per Kit
1	NOZ-059	Firesense Extreme Engine Nozzle Assembly	2
2	NOZ-058	Firesense Extreme Cockpit Nozzle Assembly	2
3	FIT-097	8mm Equal T Fitting	3
4	FIT-098	8mm Equal Bulkhead Fitting	1
5	TUBE-003	8mm Tubing	6m

The Installation Schematic Shown is for Reference Only.
 The Installation Applies to Part Numbers, FSEX2.25A, FSEX2.25M, FSEX3.0A, FSEX3.0M, FSEX4.0A & FSEX4.0M

Technical List 16 - Bottle & Bracket Installation Guide

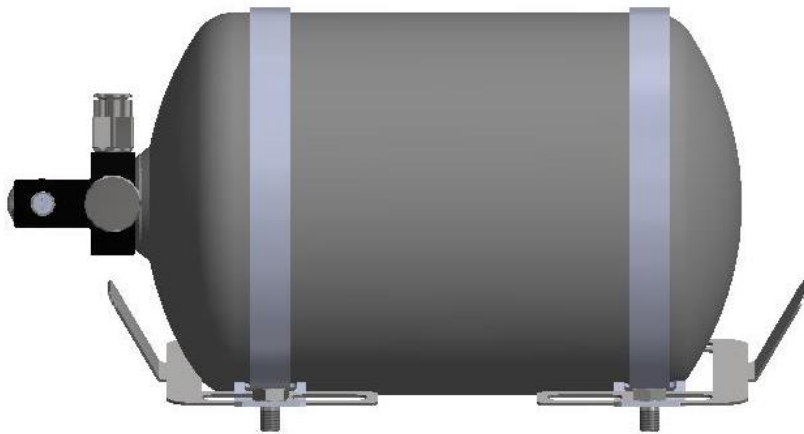

When installing the bottle into the car, it is advised that the bottle is mounted on anti-vibration rubber mounts.

The bottle mounting and straps should be used in conjunction with the anti-torpedo mounts and sufficiently sized mounting bolts (M8) and washers used to affix to the vehicle chassis.

Technical List 16 – Firesense Extreme Engine Nozzle Mounting

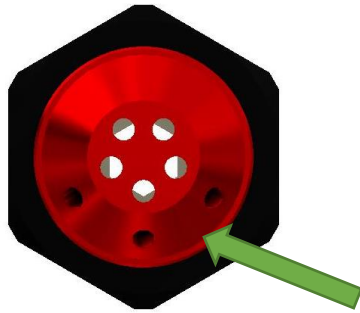

Holes must face downwards

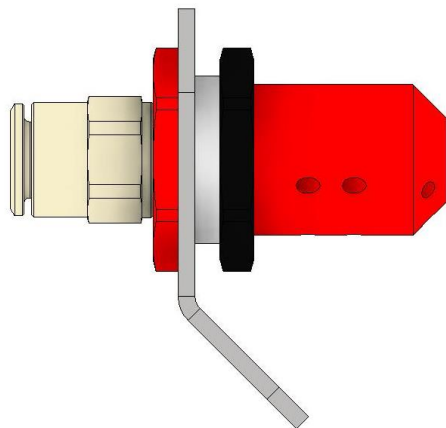

Nozzle Orientation

Ensure the nozzle is orientated as shown in the image to the left. The side nozzle should be aimed downwards.

Nozzle Mounting

The Nozzles should always be mounted to a hard mounting point using the nut supplied.

The brackets should be attached with a steel tie or jubilee clip but not a plastic cable tie. In the event of a fire, the ties can melt and when the extinguisher is operated, the pressure can force the clips to break with the nozzles moving away from the desired position

Technical List 16 – Firesense Extreme Cockpit Nozzle Mounting

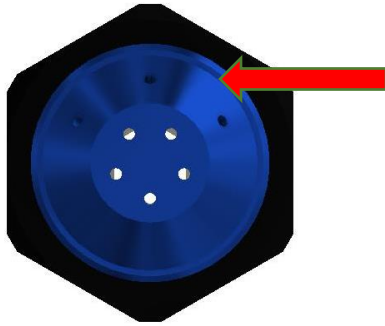

Holes must face upwards

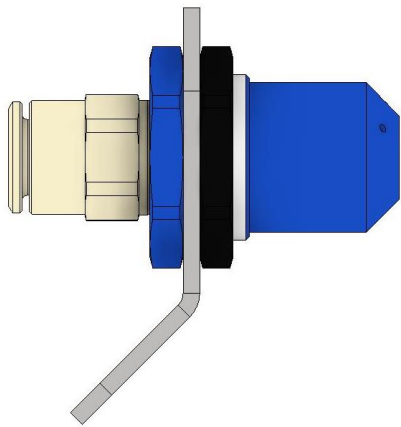

Nozzle Orientation

Ensure the nozzle is orientated as shown in the image to the left. The side nozzle should be aimed upwards.

Nozzle Mounting

The Nozzles should always be mounted to a hard mounting point using the nut supplied.

The brackets should be attached with a steel tie or jubilee clip but not a plastic cable tie. In the event of a fire, the ties can melt and when the extinguisher is operated, the pressure can force the clips to break with the nozzles moving away from the desired position

Technical List 16 – Firesense Extreme Engine Nozzle Position Guide

Inline Position

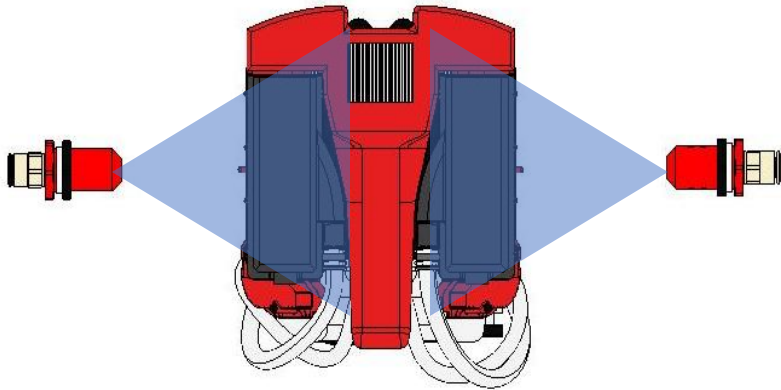

The nozzle positions play a key part in successfully bringing a fire under control and extinguishing it.

The nozzles should be as high as possible within the engine bay area and

The nozzles work by flooding the area with a clean agent gas and removing the heat quickly.

Transverse Position

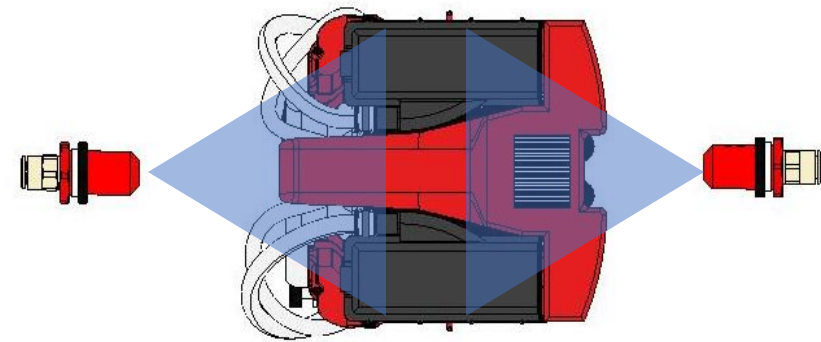

Technical List 16 – Firesense Extreme Cockpit Nozzle Position Guide

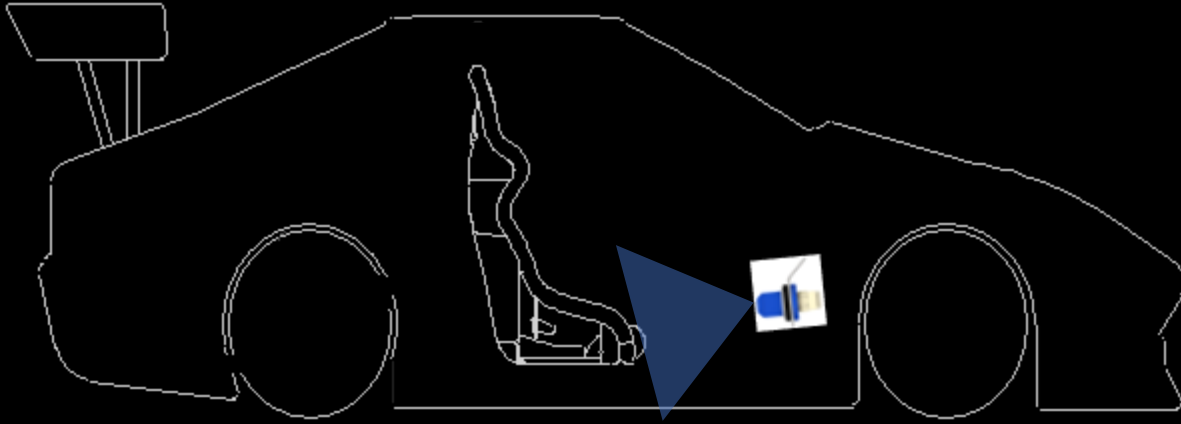

Single Occupant & Single Seater

The 1st Cockpit nozzle should be positioned towards the bulkhead aimed towards the drivers legs with the second nozzle pointed towards the drivers midriff.

Cars with a Second Occupant

The second nozzle should be positioned similar to the first nozzle aiming towards the second occupants legs

Technical List 16 - Activation System

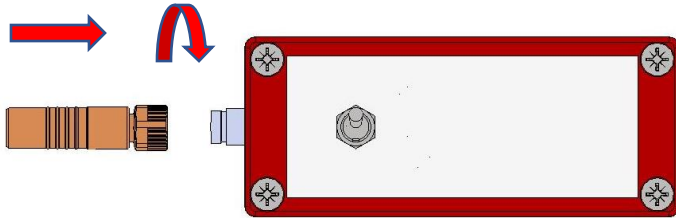

Connect one Hirschman connector to the control box using the locating slot then tighten the connector using the collar.

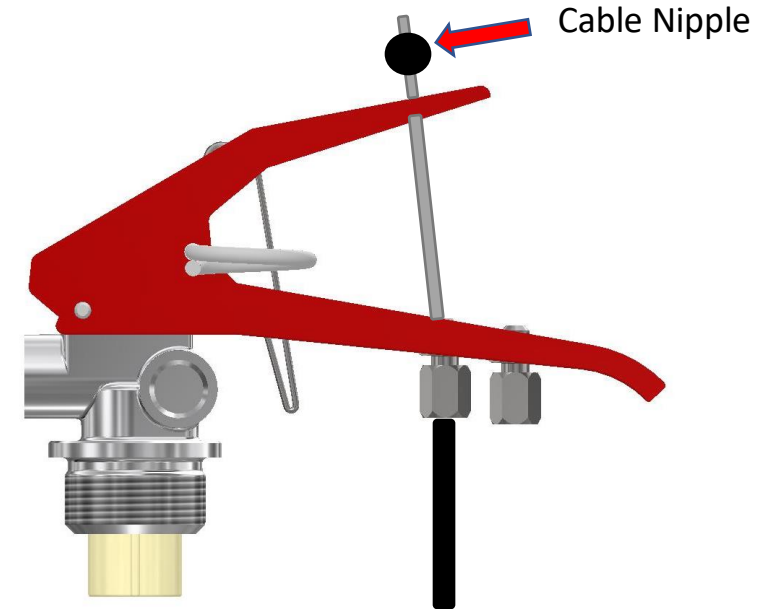

Insert the cable adjusters through the lever valve and tighten the nut.
Fit the pull cable into the adjuster and pull through the inner cable.
Place the inner cable through the top lever and fit the cable nipple leaving a small gap between the lever and nipple for testing cable free movement

Technical List 16 – Electrical Installation Guide

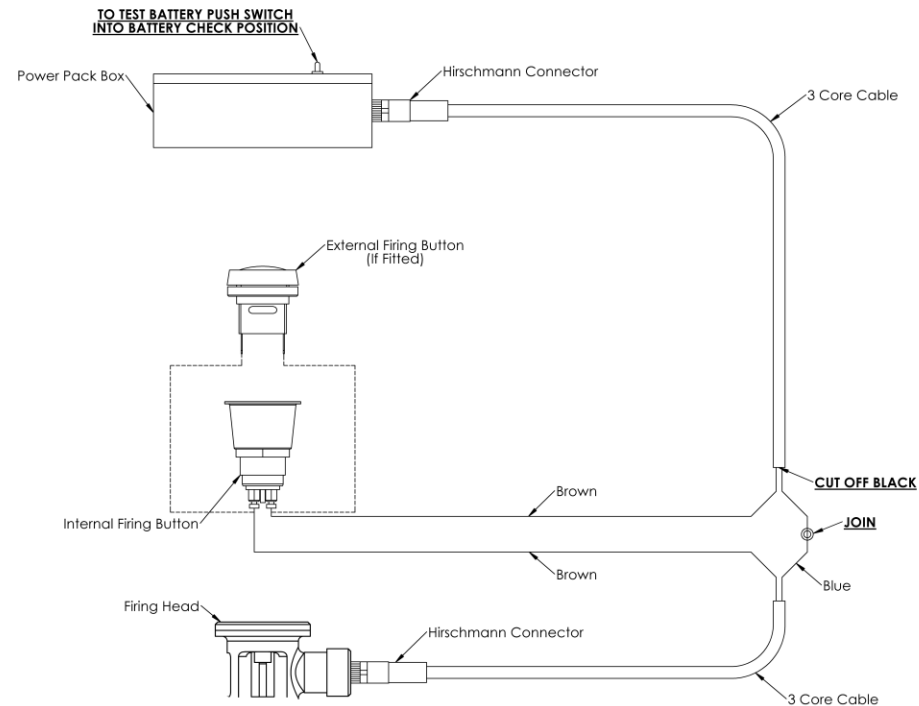

- Mount the power pack in a clearly visible position. The control box should be securely attached to the car using the supplied hook & loop tape as well as a tie.
- The Switch with a red plastic shroud is to be fitted in the cockpit so that it is in easy reach of both the driver and/or co-driver when sitting in the normal driving position and wearing fully fastened seat-belts.
- The other switch with a flexible red membrane (waterproof) is to be fitted to the outside of the vehicle, close to the exterior master switch
 - Both Should be clearly marked using the supplied 'E' Stickers
 - It is advised to waterproof any electrical connection to prevent accidental activation
- Once the system has been wired as per the wiring diagram, the following tests should be carried out to check the system is operating as required.

Technical List 16 – Electrical System Testing



The Control Box can test the continuity of the wiring, switches and firing mechanism. The switch used is a 3 way switch and any testing should be carried out with the switch in the middle position.

To Check the condition of the battery, press and hold the switch in the battery check position. Every 2 seconds the yellow light will flash. If the flashing light is dim or not working, change the battery by removing the 4 screws.

To Check the continuity, ensure the switch is in the middle position (system inactive) to prevent accidental activation and all cables are fitted.

Press the internal switch and ensure the red light illuminates.

Repeat the process for the external switch.

When you are ready to race, ensure the switch is in the system active position.

Please note, when the control box is in this position, **NO** lights will be illuminated

Technical List 16 –Maintenance Guide

After System Activation

When your fire system has been activated, the bottle must be sent for recertification to Protrust Solutions or one of our approved service agents.

(Agent information can be found on our website)

Failure to do this could result in the bottle failing at scrutineering.

The Fluid will evaporate at room temperature, but any residue can be wiped up with a clean cloth

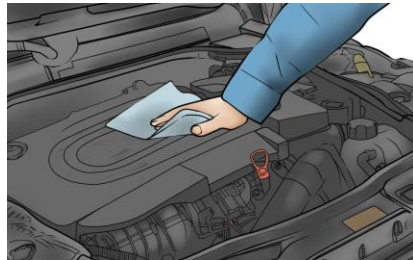

Before Refitting

When the system has been activated

1. Remove the pipework from all the nozzle and disconnect from the bottle.
2. Using compressed air, blow down each nozzle to ensure there is no blockage
3. Using compressed air, blow down the pipework from the bottle end to clear any debris from the pipes. 4. Reconnect all pipework ensuring they are fitted fully by pulling on the pipe after fitment.

Reinstall the Bottle

When the above steps are complete, you can now reinstall the fire bottle. Make sure the control box is in the inactive switch position on electrical systems before reconnecting the connector on the bottle.

Technical List 16 – Spare Parts List

Part Number	Description	Qty Per Kit
NOZ-058	Firesense Extreme - Cockpit Nozzle Assembly	2
NOZ-059	Firesense Extreme – Engine Nozzle Assembly	2
FIT-097	8mm Equal T Fitting	3
FIT-098	8mm Equal Bulkhead Fitting	1
TUBE-003	8mm Tubing	6m
MISC-002	6ft Pull Cable	1
MISC-003	12ft Pull Cable	1
BRK-013	6” Bracket & Straps (Pair)	1
BRK-007	Anti Torpedo Brackets (Pair)	1
ELEC-001	Hirschman Plug & Lead	2
ELEC-002	Internal Switch	1
ELEC-003	External Switch	1
ELEC-004	Control Box	1
STICKER-001	Small E Sticker	1
STICKER-002	Large E Sticker	1

Technical List 16 – Information

Protrust Solutions Ltd
The Mill House, Packington Hayes
Tamworth Road
Lichfield
WS14 9PN

+44 (0) 1543 756850
sales@protrustsolutions.co.uk

For a list of our service agents and dealers,
Please visit our website @

<https://protrustsolutions.co.uk/pages/store-locator-1>



Fire Extinguisher FAQ

- Q) How often should I get an Protrust Fire Extinguisher serviced?**
A) It is an FIA requirement that all fire extinguishers are serviced every 2 years for use in motorsport competitions. We allow for the missing of servicing due to inactivity if it falls within the 10 years of manufacture.
- Q) Can Protrust service any other branded Fire Extinguishers?**
A) No, Protrust will only service Protrust/SPA Extinguisher products.
- Q) What is the maximum life of a Protrust Fire Extinguishers?**
A) Protrust allow a maximum life of 10 years from the date of manufacture. This is to ensure the maximum durability of the cylinder and ultimately the safety of anyone in contact with the extinguisher.