



# FEDERATION INTERNATIONALE DE L'AUTOMOBILE

Homologation N°

**EX.033.23**

Date

06.09.2023

**FICHE DE PRESENTATION DES SYSTEMES D'EXTINCTION FIXES (NORME FIA 8865-2015)  
PRESENTATION FORM FOR PLUMBED-IN FIRE EXTINGUISHER SYSTEMS (FIA STANDARD 8865-2015)**

## 1. GENERALITES / GENERAL

### 101. CONSTRUCTEUR / MANUFACTURER

#### LIFELINE

- a) Adresse  
Address **FALKLAND CLOSE, COVENTRY, WARKWICKSHIRE. CV4 8AU. UK.**
- b) Téléphone  
Phone **+44 (0)24 7671 2999**
- c) E-mail  
E-mail **SALES@LIFELINE-FIRE.CO.UK**

### 102. PHOTO DU SYSTEME COMPLET / PICTURE OF THE COMPLETE SYSTEM



### 103. MODELE ET TYPE D'AGENT EXTINCTEUR / MODEL AND TYPE OF EXTINGUISHING MEDIUM

- |  |   |                      |                  |
|--|---|----------------------|------------------|
| a) Modèle<br>Model   | <b>ZERO 275L - 1.4-4.1M3</b>  |                      |                  |
|  | Habitacle / Moteur<br>Cockpit/ Engine                               | Habitacle<br>Cockpit | Moteur<br>Engine |
| b) Type d'agent extincteur<br>Type of extinguishing medium | <b>Monnex &amp; Coldfire + (fire fighting specific anti-freeze)</b> | <b>0.3kg</b>         | <b>1.4ltr</b>    |

**104. PLAGE DE TEMPERATURES ET CLASSIFICATION DES FEUX / TEMPERATURE RANGE AND CLASSIFICATION OF FIRES**

Plage de températures  
Temperature range

-15 A / To +80 °C

Classification des feux  
Classification of fires

- Classe I – Essence conformément à l'Art. 9 de l'Article 252 de l'Annexe J 2014 /   
 Class I – Petrol in accordance with Art. 9 of Article 252 of the 2014 Appendix J
- Classe II – Essence + jusqu'à 30% d'éthanol / Class II – Petrol + up to 30% ethanol   
 Classe III – Diesel conformément à l'Art. 9 de l'Article 252 de l'Annexe J 2014 /   
 Class III – Diesel in accordance with Art. 9 of Article 252 of the 2014 Appendix J
- Classe IV – Ethanol jusqu'à 100% ou méthanol jusqu'à 100% / Class IV – Ethanol up to 100% or Methanol up to 100%   
 Classe V – Tout autre carburant spécifique / Class V – Any other specific fuel

« Specify » E75&85

**2. DETAILS DU SYSTEME / DETAILS OF THE SYSTEM**

**201. CORPS DE L'APPAREIL / BODY**

- a) Nombre  
Number **1**
- b) Description  
Description **Dual chamber cylinder discharging to both engine bay and cockpit (par ex. un corps pour l'habitacle et un autre pour le moteur / e.g. one body for cockpit and another for engine)**
- |  | Habitacle / Moteur<br>Cockpit/ Engine | Habitacle<br>Cockpit | Moteur<br>Engine |
|--|---------------------------------------|----------------------|------------------|
| c) Matériau<br>Material  | <b>Aluminium</b>                      |                      |                  |
| d) Diamètre / Longueur [mm]<br>Diameter / Length [mm]                                  | <b>125 / 403</b>                      | <b>/</b>             | <b>/</b>         |
| e) Poids sans agent extincteur [kg]<br>Weight without extinguishing medium [kg]        | <b>1.8kg</b>                          |                      |                  |
| f) Poids complet [kg]<br>Complete weight [kg]  | <b>3.5kg</b>                          |                      |                  |
| g) Poids / volume agent extincteur [kg/l]<br>Extinguishing medium weight/volume [kg/l] | <b>0.3kg / 1.4l</b>                   |                      |                  |

A1) Corps habitacle / moteur 3/4 avant  
Cockpit/engine body 3/4 front



Marque  
Make **LIFELINE**

Modèle  
Model **ZERO 275L – 1.4-4.1 m<sup>3</sup>**

Homologation N°

**EX.033.23**

A2) Corps habitacle 3/4 avant  
Cockpit body 3/4 front

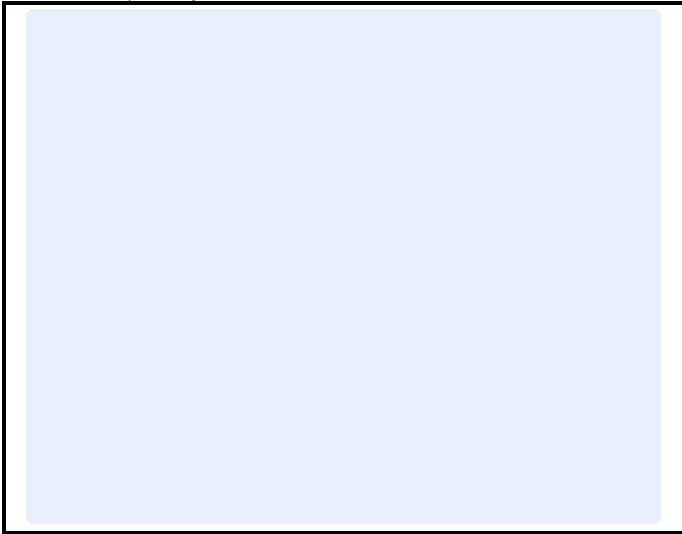

A3) Corps moteur 3/4 avant  
Engine body 3/4 front



**202. BUSES / NOZZLES**

a) Nombre  
Number  
b) Matériau  
Material

Habitacle  
Cockpit

Moteur  
Engine

1

3

Aluminium

Aluminium

B1-1) Buses habitacle 3/4 avant  
Cockpit nozzles 3/4 front



B1-2) Buses moteur 3/4 avant  
Engine nozzles 3/4 front



**203. TUYAUTERIE / PIPE WORK**

Oui / Yes



Habitacle  
Cockpit

Non / No



a) Matériau  
Material

**Ø10mm Aluminium +  
Polyamide coating x 1.5m**

Oui / Yes



Moteur  
Engine

Non / No



b) Matériau  
Material

**Ø8mm Aluminium +  
Polyamide coating x 6m**

B2-1) Tuyauterie habitacle (dessin avec diamètres des tuyaux)  
*Cockpit pipework (drawing with tube diameters)*

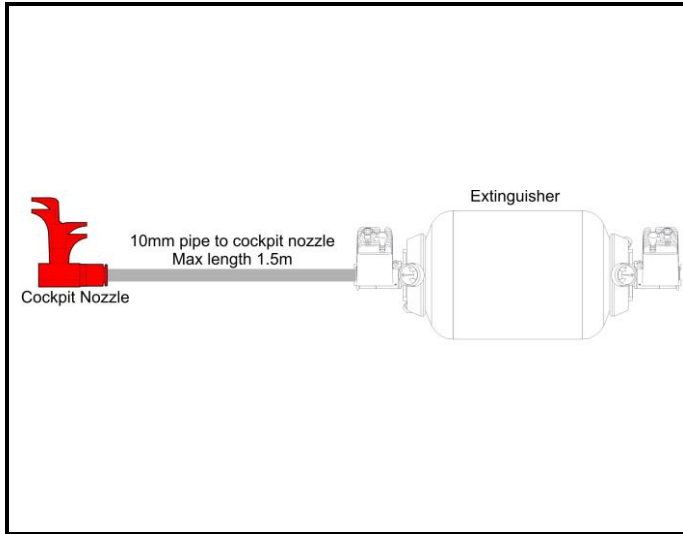

B2-2) Tuyauterie moteur (dessin avec diamètres des tuyaux)  
*Engine pipework (drawing with tube diameters)*

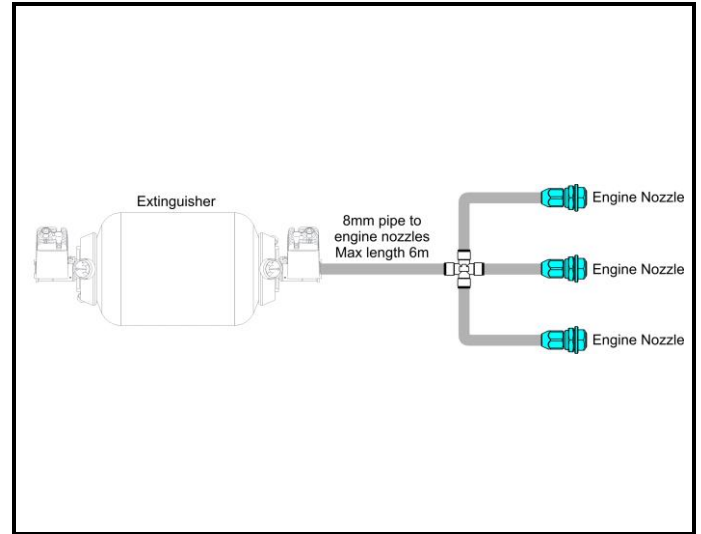

**204. ACTIVATION / ACTIVATION**

a) Type d'activation  
*Type of activation*

Mécanique <i>Mechanical</i>		Électrique <i>Electrical</i>	
Oui / Yes	Non / No	Oui / Yes	Non / No
<input type="checkbox"/>	<input checked="" type="checkbox"/>	<input checked="" type="checkbox"/>	<input type="checkbox"/>

C1-1) Système d'activation mécanique (système complet)  
*Mechanical activation system (complete system)*



C1-2) Levier de décharge du système d'activation mécanique  
*Discharge lever of the mechanical activation system*



Marque  
Make **LIFELINE**

Modèle  
Model **ZERO 275L – 1.4-4.1 m<sup>3</sup>**

Homologation N°

**EX.033.23**

C2-1) Système d'activation électrique (système complet)  
*Electrical activation system (complete system)*



C2-2) Système d'activation électrique (boîtier électrique)  
*Electrical activation system (electrical box)*



205. PHOTO DE L'INDICATEUR QUI MONTRE QUE LE SYSTEME DE DECHARGE DE PRESSION A ETE ACTIVE / PHOTO OF THE INDICATOR THAT SHOWS THAT THE PRESSURE RELEASE SYSTEM HAS BEEN ACTIVATED



Marque  
Make **LIFELINE**

Modèle  
Model **ZERO 275L – 1.4-4.1 m<sup>3</sup>**

Homologation N°

**EX.033.23**

### 3. ETIQUETTES D'HOMOLOGATION ET DE MAINTENANCE / *HOMOLOGATION AND MAINTENANCE LABEL*

#### 301. ETIQUETTES / LABELS

	Etiquette d'homologation <i>Homologation label</i>	Etiquette de maintenance <i>Maintenance label</i>
a) Dimensions [mm] <i>Dimensions [mm]</i>	<b>94 x 54</b>	<b>94 x 28</b>
b) Couleur du fond de l'étiquette <i>Label background colour</i>	<b>Turquoise</b>	<b>Turquoise</b>

D1-1) Etiquette d'homologation collée sur le corps  
*Homologation label glued on the body*

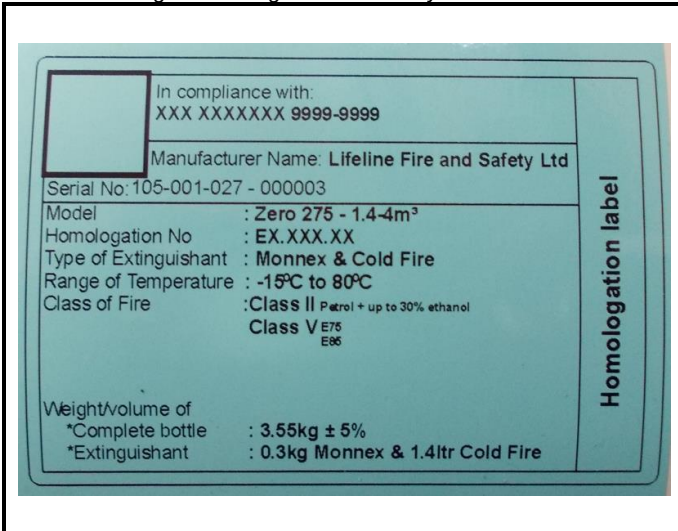

D1-2) Etiquette de maintenance collée sur le corps  
*Maintenance label glued on the body*

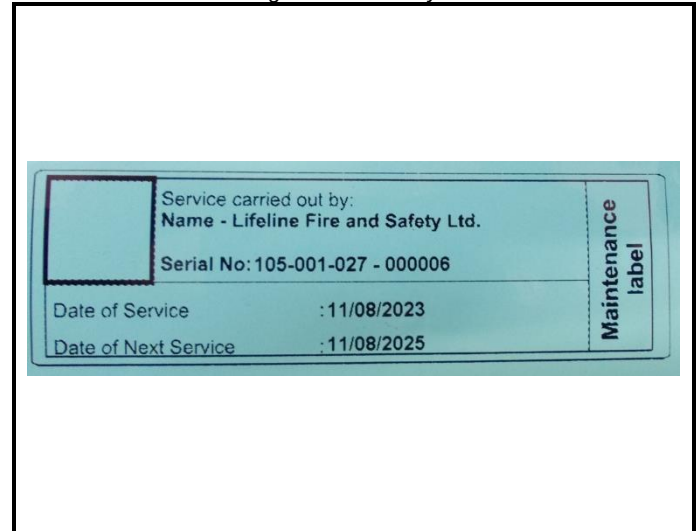

Marque  
Make **LIFELINE**

Modèle  
Model **ZERO 275L – 1.4-4.1 m<sup>3</sup>**

Homologation N°

**EX.033.23**

**INFORMATIONS COMPLEMENTAIRES / COMPLEMENTARY INFORMATION**

I

