

CESAL5L & CESAL5S USER MANUAL



Table of Contents

1. INTRODUCTION	2
2. PRECAUTIONS FOR USE.....	3
3. TYPE-TESTING AND INTENDED USE	5
4. COMPONENTS AND SYSTEM LAYOUT.....	6
5. INSTALLING THE SYSTEM	10
6. COMPONENTS AND CONNECTION OF THE ELECTRICAL CONTROL	13
7. INSTALLING THE ELECTRICAL CONTROL BOX	17
8. TECHNICAL SPECIFICATIONS	19
9. MAINTENANCE	19
10. WARRANTY.....	20

USE AND MAINTENANCE OF YOUR OMP EXTINGUISHING SYSTEM

OMP Racing s.p.a. thanks you for choosing one of its products.

This manual will provide the necessary information to correctly install and use your extinguishing system.

If you have any questions, please contact OMP Racing s.p.a. Customer Service at +39 010 96501, or consult your local retailer. Information about OMP products is also available on www.ompracing.it and www.ompamerica.com.

1. INTRODUCTION

This manual contains important information and recommendations for your safety. These WARNINGS are preceded by the symbol



WARNING

Failure to abide by these WARNINGS may reduce the effectiveness of your extinguishing system and lead to an increased risk of injury, or even death, and also voids the warranty.

Before installing and using your extinguisher system, read the entire manual observe all recommendations, and store the manual in a safe place for future reference.



WARNING

Installation or use of the extinguishing system not complying with information provided here can reduce the effectiveness of your extinguishing system and increase the risk of injury, or even death, voids the warranty and releases OMP Racing s.p.a. from any responsibility towards the user.

2. PRECAUTIONS FOR USE



WARNING

The extinguishing liquid is irritating to eyes, skin, and respiratory tracts and is harmful if swallowed. Avoid ingestion, inhalation, contact with eyes and prolonged and repeated contact with the skin.

In the event of contact with eyes, wash thoroughly with water for at least 10 minutes. In the event of accidental contact with the skin, immediately wash the affected body part with plenty of soap and water. In the event of inhalation, bring the subject to a well ventilated area. If any signs of illness occur, seek medical assistance.

In the event of ingestion, do not induce vomiting, but seek immediate medical assistance. The extinguishing liquid contains ethylene glycol.



WARNING

Before every race, check the control unit battery charge level. If the battery is out, the system will not turn on.

The control unit can detect the battery charge level and gives an error signal if it is not sufficient for 24 hours use. In this case, see section 7 about battery replacement.



WARNING

Before every race, check the pressure inside the bottle

The pressure gauge has to indicate a value of the pressure inside the green area

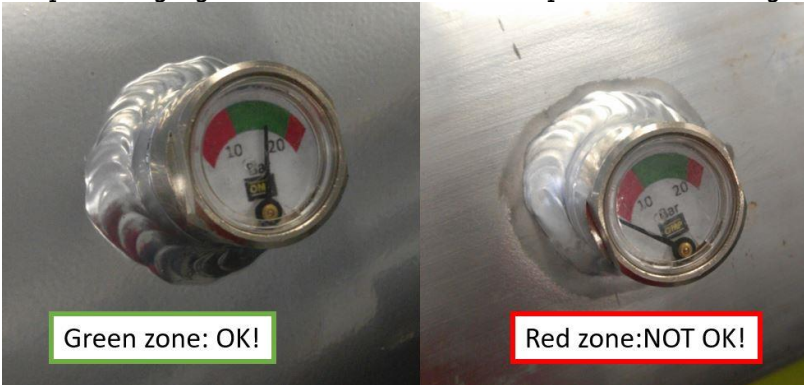

Fig. 1 Pressure gauge



WARNING

Before every race, check the cap who cover the pressure release system. If the cap is not covering the pressure release, maybe an overpressure occurred.

If the cap is compromised, the system could be damaged and the bottle shall be replaced or serviced by OMP Racing or an authorized licensee.



Fig. 2 Pressure release cap



Corrosion, if any makes the system unsafe and reduces its functionality.

When the vehicle is used for long periods in damp or saline environments, the system shall be checked or replaced.

Corrosion phenomena can compromise the functionality of the extinguisher system.

To protect your system against corrosion, make sure that the vehicle electrical system has no leaks. Leaks from the electrical system can result in electrolytic corrosion. If a battery unexpectedly loses its charge, leaks from the electrical system might be present. Other signs can include malfunctions of indicator lights and/or control units in the vehicle.

If your vehicle has not been used for an extended period of time or has been subject to flooding or lengthy exposure to high salinity environments, have your system checked to make sure that there is no corrosion.



Complying with FIA Standard, the system is designed to work between -15°C up to 80°C. Effectiveness and efficiency of the system out of this range of temperature is not guaranteed. Higher temperature can damage the system

3. TYPE-TESTING AND INTENDED USE



WARNING

An extinguishing system that is unsuitable for your vehicle or that is not properly installed, will provide reduced protection and will increase the risk of injury or even death.



WARNING

The CESAL5 system has two versions that must be chosen according to the cockpit volume.

CESAL5L homologation number is EX.0XX.19.

CESAL5L is homologated from 2.2 m³ up to 4.1 m³ cockpit volume.

CESAL5S homologation number is EX.0YY.19.

CESAL5S is homologated from 1.35 m³ up to 2.5 m³ cockpit volume.

Please check the cockpit volume of the car where the system is installed.

Detailed information is available on FIA Technical list n°52 “FIA STANDARD 8865-2015 PLUMBED-IN AND HAND-HELD FIRE EXTINGUISHER SYSTEMS” and in the FIA 8865-2015 standard. These files are available and updated on the FIA website



WARNING

CESAL5 extinguisher systems are suitable for installation on saloon cars using **ONLY** the following fuels:

- Gasoline
- Diesel
- Gasoline + up 30% Ethanol or Methanol
- E85

If you purchased a system that is not suitable for your vehicle, do not proceed with installation and contact your retailer.



WARNING

Only use original OMP parts and components when installing the system. Using non-original components invalidates the homologation of the system and voids the warranty.

CESAL5 extinguishing systems can extinguish a fire in the type of vehicle they are suited for under design conditions. Nonetheless, keeping in mind the large number of variables involved in a fire that are difficult to anticipate and control, it cannot be guaranteed that this goal will be achieved under all conditions.

N.B.: CESAL5 extinguishing systems are intended to provide protection for the vehicle occupants and not for the vehicle itself.



WARNING

Motorsport is an inherently dangerous activity. The correct use of the extinguishing system in no way exempts the user from abiding by driving rules or from using other safety devices required or recommended when driving.

4. COMPONENTS AND SYSTEM LAYOUT

CESAL5 system components:

	Q.ty	Use	
		Cockpit	Engine bay
Bottle	1	1	-
Ø 8 mm Al tube	10m	Up to 6m	Up to 6m
Fireproof sleeves Ø 8 mm tube	12m	6m	6m
NOVEC Nozzles (green)	2	2	-
AFFF Nozzles (black)	3	-	3
T connections for piping	1	-	1
Y connections for piping	2	1	1
L connections for connecting nozzles	3	-	3
Straight connections for nozzles	2	2	-
NOVEC nozzles Brackets	2	2	-
Steel cable ties for NOVEC nozzles	4	4	-

Layout of the CESAL5 system:

Figure 2 shows the design layout of connections in the CESAL5 system.

Two nozzles (green anodized) must be mounted in the cockpit and three nozzles (black anodized) in the engine bay. For further information about nozzles assembly, see the subsequent sections .

All pipes used in the CESAL5 system have 8 mmØ. All the pipes are completely made with aluminum. Plastic tubes are not allowed.

All pipe MUST be covered with the appropriate fireproof sleeves provided with the system.

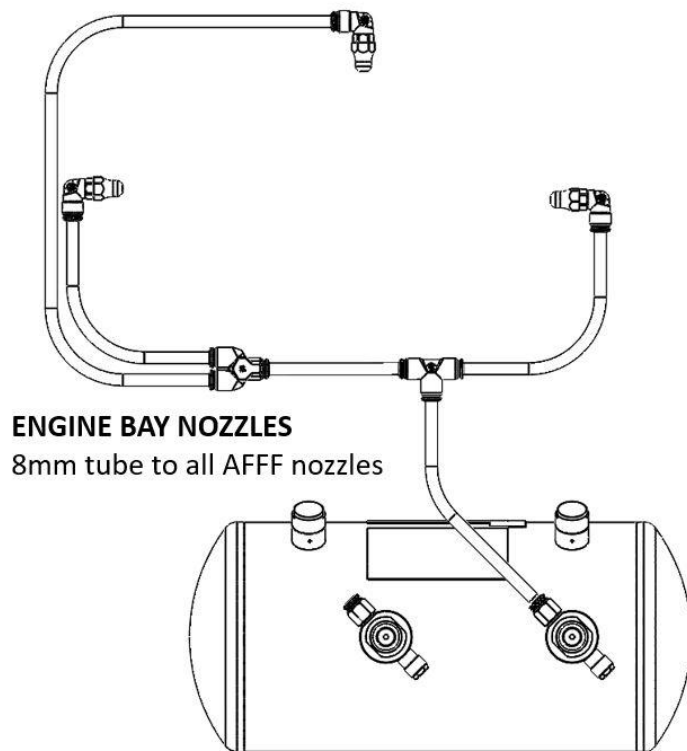
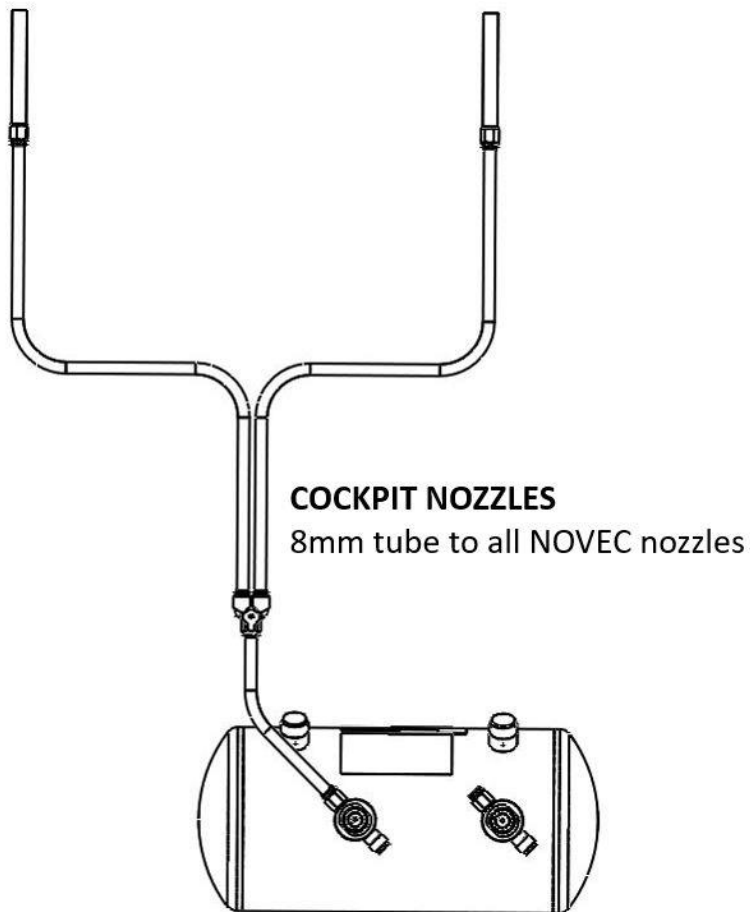

Fig. 2 System layout

Placement of the bottle:

The bottle must be installed where it does not obstruct a rapid exit from the vehicle in case of emergency.

The bottle must be placed where homologation label, maintenance label, FIA hologram and tamper-proof seal on the pressure release system can be read by a scrutineer.

Bottle location is free within the cockpit volume but is recommended to mount it transversely and away from strong heat sources. Furthermore, OMP recommended preferable placement for different types of cars. The correct approach is to use less aluminum pipe as possible. The shortest the tubes are, the most efficient the extinguisher system is. CESAL5 is homologated with a **maximum of 6 meter** tube for engine bay and a **maximum of 6 meter** tube for cockpit.



WARNING

The bottle must be so installed that it does not obstruct a rapid exit from the vehicle in the case of emergency.

Placement of the nozzles in the cockpit:

Nozzles shall be placed into the cockpit, according to the diagram in Figure 3.

The right nozzle (Nozzle 1) shall be placed on the right front pillar or equivalent position. The left nozzle (Nozzle 2) shall be placed on the left front pillar or equivalent position. The nozzle has to be placed at least 20 cm above the floor and can be fixed to the rollcage or on an equivalent point located in that area. The nozzle should be placed aim the space between the seat and the door.

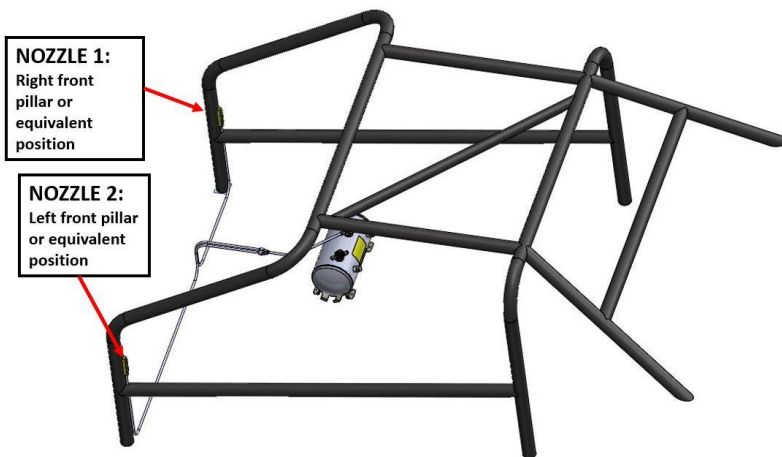

Fig. 3 Cockpit installation



WARNING

The installation shall comply with FIA Appendix J Art 253 & 283.

Nozzles must be fixed to a rigid part of the car and in any case can be fixed to the rollcage padding.

If possible, fix the nozzle directly to the rollcage tube using steel cable ties (i.e. Panduit).



WARNING

Do not use plastic cable ties to fix the nozzle ONLY metal fastening system shall be used.



WARNING

Do not cover the nozzles: the obstruction of the holes can make the system inefficient.



WARNING

The hoses into the cockpit shall always be covered with the appropriate fireproof sleeves supplied with the system.

Placement of the nozzles in the engine bay:

Nozzles shall be directed toward the areas of greatest flammability risk (i.e. turbo, oil radiator, fuel injectors, manifold). The nozzle spray is a cone of 80° of AFFF foam with a length of 800mm.

Maintain a recommended 20 cm clearance in front of each nozzle in order to obtain the maximum protection.

In Figure 6 a possible installation scheme is shown.

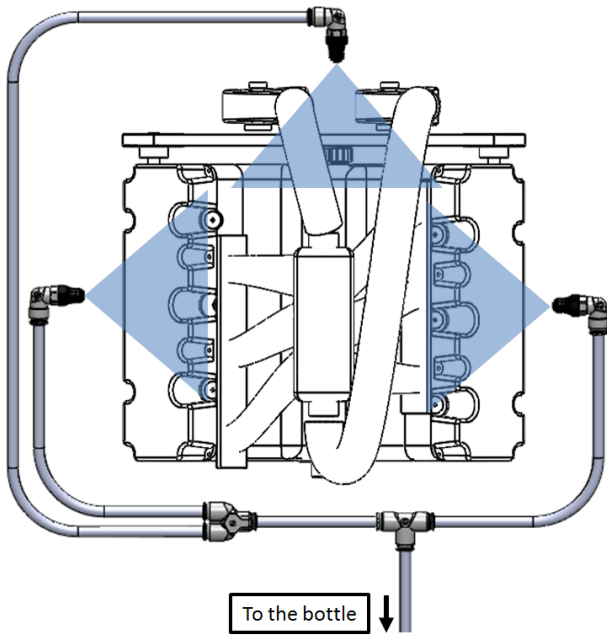

Fig. 4 Engine bay layout

! WARNING

Do not cover the nozzles: the obstruction of the holes can make the system inefficient.

! WARNING

The engine bay hoses shall always be covered with the appropriate fireproof sleeves supplied with the system.

! WARNING

Before assembling the nozzles and making the connection to the bottle valve, hoses shall be thoroughly cleaned.

Any dirt or shavings inside the hoses could clog the nozzles and make the extinguishing system ineffective.

! WARNING

Under no circumstances hoses with cracks or leaks can be used.

! WARNING

Do not bend hoses to a radius of less than 50 mm.

Curvatures with a radius of lower than 50 mm may reduce the system flow.

! WARNING

Under no circumstances lubricants can be used to aid the assembly. The use of lubricants can reduce the extinguishing properties of the system

5. INSTALLING THE SYSTEM

Installing the bottle

Select a location on the chassis that is adequately thick and sturdy, or use a reinforcing counter plate. The location chosen shall allow visibility of homologation label, maintenance label, FIA hologram and tamper proof of the pressure release system.

Insert the wormgear hose clamps in the dedicated slots in the support bracket. Do not close the wormgear hose clamps.

Fasten the support bracket, provided with the system, to the vehicle chassis using at least no. 4 screws M6 class 8.8 or higher. Use flat washers and appropriate locking devices (spring washers or self-locking nuts or thread locker). Screw the bolts (or nuts, as appropriate) with a recommended torque of 8 Nm. Place the bottle on the brackets. Close and fasten the wormgear hose clamp being careful not to clamp the aluminum pipe on the bottle. The worm gear hose clamp shall be fastened using 8 Nm torque.

OMP standard bracket already includes the anti torpedo tabs.

Fig.7 shows how to install it.

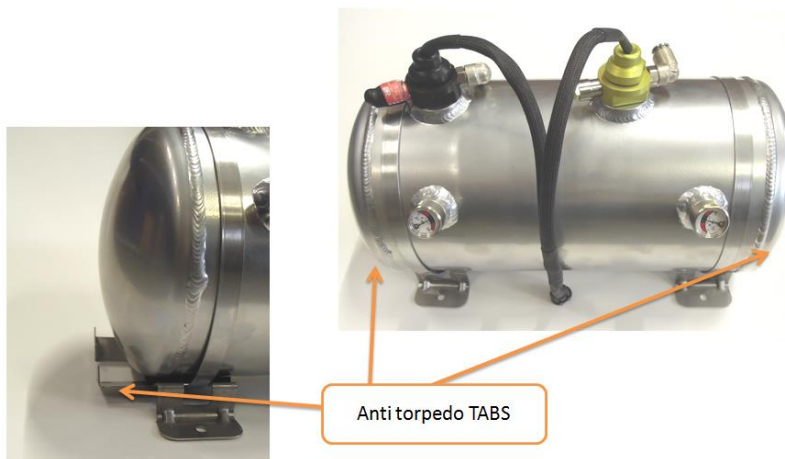

Fig. 5 Anti torpedo tabs

Installing the hoses and nozzles:

When planning the hose path, avoid curves with a radius smaller than 50 mm. To overlay narrow curves may reduce the system flow and compromise the hose durability.

The extinguishing system hoses shall always be completely covered with the appropriate fireproof sleeves.



WARNING

Use the aluminum tube included with the extinguisher.
In any case plastic tube or fasteners can't be used.



WARNING

The extinguishing system tubes shall always all be covered with the appropriate fireproof sleeves provided with the system.



WARNING

Use the fittings provided by OMP to assembly piping of the extinguisher system. Plastic fittings are not allowed.

If you need spare fittings contact OMP Racing or an official retailer.

When deciding the length of the hoses, keep in mind that the length of the hose to be inserted into the fittings is:

- 17 mm for the T connectors on \varnothing 8 hoses
- 17 mm for the L connectors on \varnothing 8 hoses
- 17 mm for the 90° connector on \varnothing 8 hoses
- 17 mm for straight connector on \varnothing 8 hoses

To make a proper installation of the connector, use the following steps:

1. make a sign on the right measure on the tube to be pushed into the connector (figure 9)

2. push the tube inside the connector until the sign made in step 1 is visible.

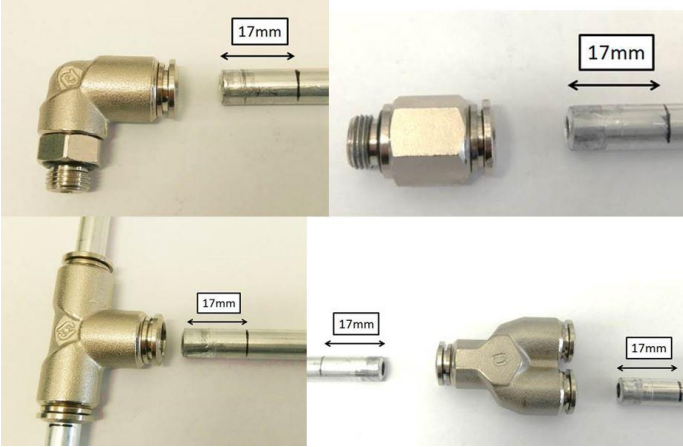

Fig. 6 Fittings installation

The tube-end cut shall be perpendicular to the axis of the hose, taking care not to cause choke points in the section or create shavings. Use fine abrasive paper to gently smooth the cut, making sure to remove any dust residue by means compressed air blown from the opposite end of the hose.



WARNING

Any dirt in the hoses can block the nozzles, rendering the extinguishing system ineffective.

The are two different types of nozzles:

- Nozzle for engine bay (black, for AFFF, ref. Figure 10)
- Nozzle for Cockpit (green, for NOVEC 1230, ref. Figure 11)



Fig. 7 Engine bay nozzles



Fig. 8 Cockpit nozzles

Do not use lubricants under any circumstances: they can obstruct the holes of the nozzle itself or the turbinator inside it. In addition to securing the hoses, connectors shall also be fastened to the vehicle in order to precisely and firmly establish the nozzle angle.

Fix the nozzle with the proper connection:

Engine bay nozzles are fixed with the 90° connectors (Figure 10)
Cockpit nozzles are fixed with the 2 straight connectors (Figure 11).
The recommended torque to fix nozzles and connection is **5 Nm**.

To have a proper system installation it is recommended to use the following steps:

1. define the position of the bottle (see Chapter 4)
2. secure the bottle in the vehicle
3. define the desired position for the nozzles (see Chapter 4)
4. extend the hose starting from the valve connector (taking into account the insertion of the hose into the valve connector), with the various branches all the way to the farthest nozzles
5. in the desired position for the nozzles, place the hose near the connectors that will house the nozzles and mark the cutting length, taking into account the insertion of the hoses indicated above
6. cut the hose at the desired length
7. mark the desired insertion lengths from the end of the hose
8. cover the hose with the appropriate fireproof sheathing
9. insert the hose onto the quick connectors and make sure that the edge of the connector edge is collinear with the desired insertion mark (tol. $\pm 0.5\text{mm}$).
10. thoroughly clean the hose from dust and shavings.
11. screw the nozzles onto the connectors and make sure that the position of the nozzles is compliant with the indication in Chapter 4. Make corrections if needed and finally fasten the system into the vehicle, taking care to secure not only the position of the nozzles, but also their orientation (prevent them from rotating around the axis of the hose).



WARNING

Secure the nozzle so that it cannot rotate around the hose and to be sure that the jet orientation is fixed.

6. COMPONENTS AND CONNECTION OF THE ELECTRICAL CONTROL

Electrical control components

	Q.ty	Use	
		Cockpit	Vehicle exterior
Electrical box	1	1	
Cable	2	1	1
External activation button	1		1
Stickers	2	1	1
Fireproof sleeves	12m	As needed	As needed



WARNING

The Electrical Control Unit is IP 55 certified. However, if the Control Unit circuit gets wet, unwanted activation of the extinguishing system might occur.

See paragraph 7 about the control unit installation aimed to minimize the risk of water penetrating the unit.

Electrical connections diagram

Your system can be activated in two ways: by the activation button located on the electrical control unit, or by the external activation button.

The general wiring diagram is shown in Figure 12.

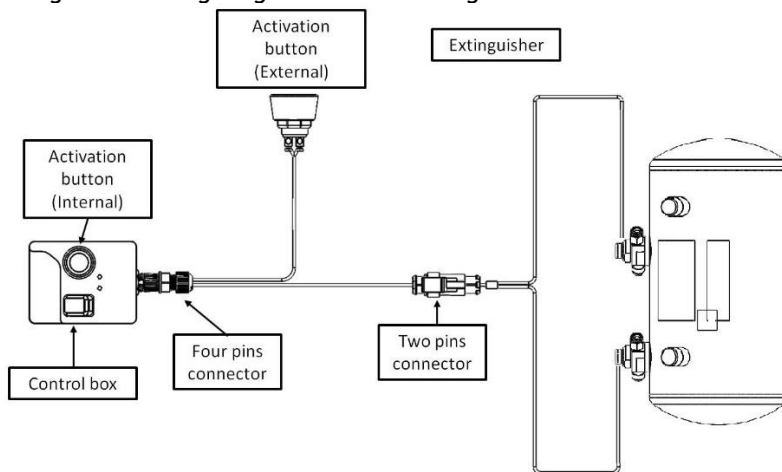

Fig. 9 Electrical connection

Electrical control box

The control box (Fig. 13) has one activation button (red), one switch for the test/armed position, two LEDs (orange and red) and a 4 pin connector.

As explained in the FIA 8865 standard, the electrical box shall comply with the specific operating mode explained below.

Switch in TEST position:

Before every race, the extinguisher system shall be tested in order to check the integrity of the electrical wiring and the battery charge level.

Set the proper switch to TEST position: in this configuration it is impossible to activate the extinguisher system. Once the switch is set to TEST mode, the control box can run a check of the all electrical parameters of the extinguisher system.

To start the check, push one of the activation buttons.

It is mandatory to make two different checks by pushing both activation buttons.

After testing, there can be 2 different scenarios.

Test OK: the orange LED is always ON for a period of at least 5 seconds.

Test not OK: the orange LED starts to flash for at least 10 seconds then goes out. In this case, a technical issue is occurring (i.e. electrical discontinuity, actuator problem, battery charge level not sufficient).

Note

When the LED is ON to indicate "test ok", the light can flicker, in order to not drain too much battery.

When the test is "not ok" the flash is evident.

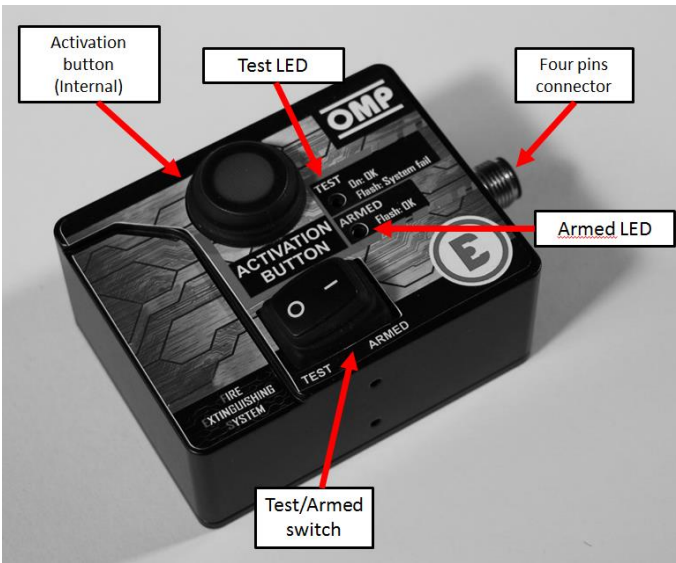

**Fig. 10 Control box
Switch in Armed position:**

When the switch is set from test to armed position the electrical box runs an automatic check to ascertain that there is no anomalies.
 If this test is ok, the orange LED is ON for 5 seconds and then, when the system is ready to be activated, the red LED starts to flash at a low rate.
 If the test fails, the orange LED starts to flash for 10 seconds and then the red LED remains off.

Control box pin-out:

The output of the control box passes through an IP68 certified, 4 pin connector .

The connector pin-out is shown in Figure 14:

- Pins 1 and 2: connection to the external button (not polarized)
- Pins 3 and 4: connection to the bottle (not polarized)

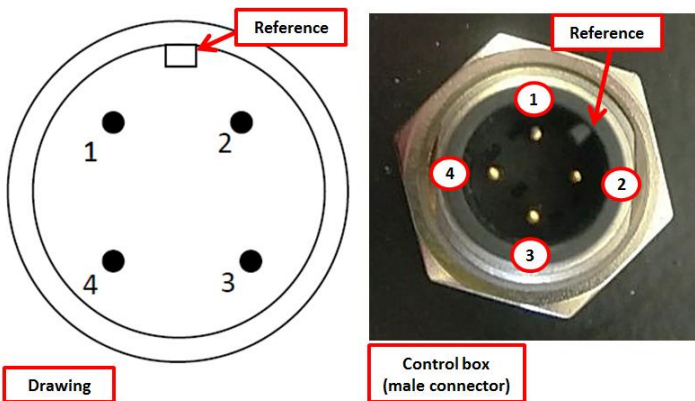

Fig. 3 Control box pin-out

Obviously, in cable female connector, pins are mirrored, as shown in Figure 15.

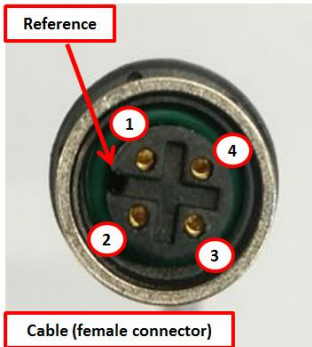

Fig. 42 Female connector (wiring)

Extinguisher system wiring

As shown into Figure 16, your system includes:

- **Control unit**
- **Control unit wiring** with two raw ends and the other end with a 4-pin connector to connect to the control unit. The longer wire (2m) is used to connect the bottle, the shortest wire (1m) is used to connect the external button.
- **Electrical wiring** with one raw end and one end with a plug for the connection of the extinguisher bottle.
- **External activation push button**
- **4 meter fireproof sleeves** to protect the wiring in case of fire.

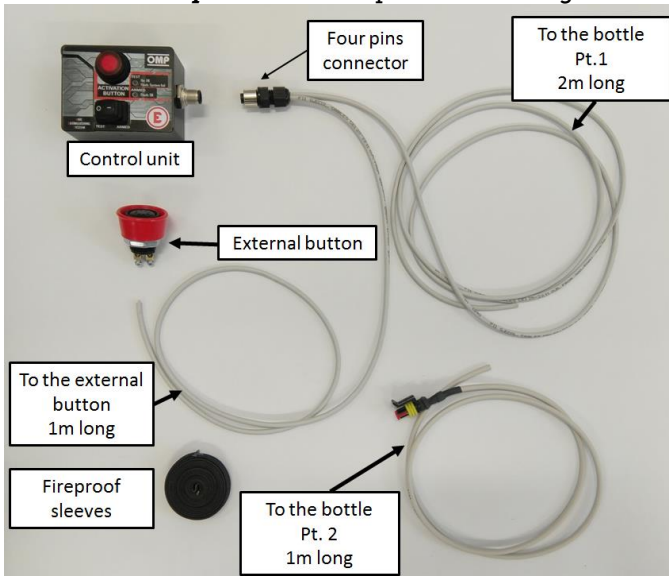

Fig. 53 Wiring



WARNING

All the electrical cables shall be covered with the fireproof sleeves provided with the system. Remember to cover the cable before welding or fixing the different parts of it.

The cable shall be covered with fireproof sleeves in order to protect it in case of fire, as shown in Figure 17.

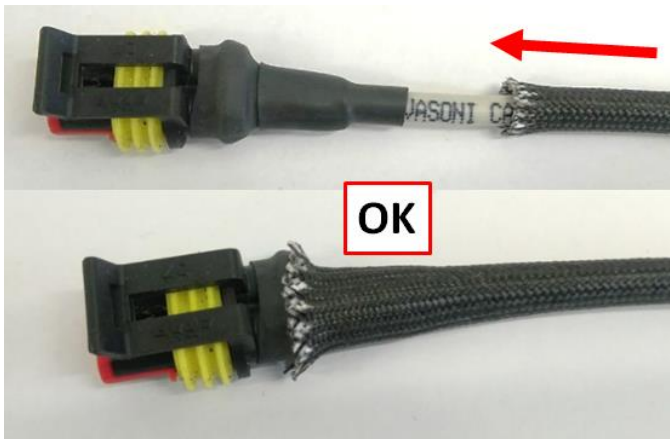

Fig. 64 Fireproof sleeves installation



WARNING

Before connecting the electrical cables to the bottle and control units, check the proper matching of the pin out connection with a multimeter, or similar device.

The error in the electrical connection can cause a failure of the extinguisher system. Follow the pin-out drawing shown in Figures 14 and 15.

DO NOT RELY ON THE CABLE COLOR, which may vary from system to system. Instead, RELY ON THE POSITION of plugs, which is the same in all OMP control units.



WARNING

Joint the 2 wires by welding or using crimp connector (i.e. Faston) The joint between the two cable parts shall be resistant and properly insulated.

The 4 pin control unit connector is equipped with a locking mechanism, so that it will not come loose by accident.

The position of the control unit shall comply with the following requirements:

- Control units shall be reached by the drivers (and co- drivers if any) seated in driving position with the seat belt tight.
- It shall always be possible to see the unit LED in all conditions.
- The control unit shall be protected from direct exposure to water.

The second button (external button) shall be mounted outside the vehicle.

Two adhesive marks, provided with the system, shall be located near both activation buttons.

When the black switch is in ARMED position, whenever either of the buttons is pushed, the extinguishing medium will be immediately expelled from the nozzles and the spray cannot be stopped.

Therefore, it is advisable to set this switch to TEST position when the vehicle is not used, and to switch it to ON when the vehicle is started.

If the car is not used for a long period, remove the battery from the control box.



WARNING

When the control box switch is set to TEST position, the extinguishing system is disabled. Make sure that the switch is in ARMED position before using the vehicle.

7. INSTALLING THE ELECTRICAL CONTROL BOX

The position of the control unit shall comply with the following requirements:

- Control units shall be reached by the drivers (and co-drivers if any) seated in driving position with the seat belt tight.
- It will be always possible to see the LED of the unit in all conditions.
- The control unit shall be protected from direct exposure to water.



The Electrical Control Unit is IP 55 certified but if its internal circuit gets wet, unwanted activation of the extinguishing system might occur. Tighten the screws properly.

Care shall be taken to install the Control Unit in an area where it is protected from direct splash of water. If it is not possible to place the Control Unit in an area where it is protected from water: it shall be protected with a water-proof nylon or similar material cover.

It is suggested never to install the control box directly on the floor without using a raising spacer. If the control unit is installed on the floor, it shall be at least 15 mm raised by a spacer.

Open the rear compartment of the control unit (fastened with 4 screws) and install a fully charged 9V battery into the control unit, then reclose the compartment with the provided screws; (See Figure 18)



Fig. 75 Battery connection

Secure the control unit in the vehicle with at least two M3 screws.

Position the second button outside the vehicle near the windshield bottom on the driver's side, then connect and secure it in place with the ring nut.



Any short circuit between the connecting elements on the rear of the button is read by the system as an activation signal. When installing all components make sure that they are protected from the short circuit risk (for example due to a contact with external parts or a splash of water).

If possible, protect each connection with silicon caulk, electrical tape or similar items.

To complete the connection from the control unit to the system bottle, insert the plug until the locking lever reaches its reference, as shown into Figure 19.

It is strongly recommended to set the switch to TEST mode before connecting the control unit to the bottle.

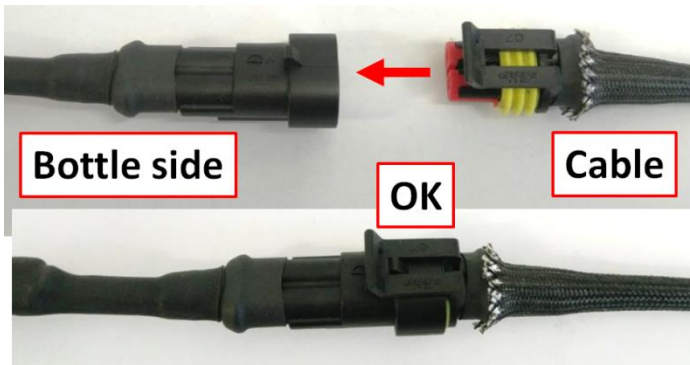

Fig. 86 Bottle connection



WARNING

If the bottle is connected to the Control Unit switch in ARMED position, the system might turn on even if electrical connection does not work properly.

Once the installation is completed, check the system by setting the control unit switch to TEST mode and push the activation button. In this way, the control unit will confirm the proper installation as indicated in page 22.

Note

The control unit checks the whole electrical system: if the bottle is not connected the result will be NOT OK.

If, after checking connections and installing a new 9V battery, the LED still does not turn on, contact your local retailer.

When the result is NOT OK, even in case of correct electrical connections, the bottle is connected to the system and the 9V battery is fully charged, please contact your OMP retailer.

It is recommended to replace the electrical control unit 9V battery before every race.

8. TECHNICAL SPECIFICATIONS

System

<u>Bottle pressure</u>	<u>pressurized at 14 bar</u>
<u>Pressurization:</u>	<u>By Nitrogen</u>
<u>Battery power</u>	<u>9V alkaline 6LR61</u>

Extinguisher Agents

Cockpit

<u>Type</u>	<u>NOVEC 1230</u>
<u>Working temperature</u>	<u>-15 / +80 °C</u>
<u>Aspect</u>	<u>Transparent</u>
<u>Density at 20°C</u>	<u>1.6 (kg/dm3)</u>
<u>NOAEL</u>	<u>10%</u>
<u>Boiling point</u>	<u>~ 50°C</u>
<u>GWP</u>	<u>1</u>
<u>Chemical Comp.:</u>	<u>C₆F₁₂O</u>

Hazardous components none

Further info is available in 3M website

Engine Bay

<u>Type</u>	<u>AFFF</u>
<u>Working temperature</u>	<u>-15 / +80 °C</u>
<u>Aspect</u>	<u>Red liquid</u>
<u>Density at 20°C</u>	<u>1.07 (kg/dm3)</u>
<u>PH</u>	<u>7 ±1</u>
<u>Boiling point</u>	<u>~ 100°C</u>
<u>Biodegradability</u>	<u>Rapidly biodegradable</u>

B.O.D. 220,000 mgO₂/l

Chemical Comp.: aqueous solution containing hydrocarbon surfactants, fluorosurfactants, and antifreeze agents

Eco-toxicity Rapidly biodegradable

Hazardous components ethylene glycol, urea

9. MAINTENANCE

Before every race:

- Make sure that the tamper-proof seal into the over pressure valve of the bottle is whole and intact. If the tamper-proof seal is compromised, have the system checked by an OMP authorized service center or be replaced.
- Check the charge level of the 9V battery and replace it if needed.
- Set the system electrical control unit switch to TEST position and check the system by pushing an activation button. Repeat the test with the second activation button.
- Before the race, set the control unit switch to ARMED position.



WARNING

When the control box lever switch is in TEST position, the extinguishing system is disabled. Make sure that the switch is in ARMED position before using the vehicle.



WARNING

EVERY 2 YEARS FROM THE DATE INDICATED ON THE BOTTLE MAINTENANCE LABEL , the system shall be checked as for the following action list:

- Return the bottle to an authorized OMP service center
- Clean the system as follows:
 1. Disassemble the nozzles from their connectors and the connectors from the hose.
 2. Blow compressed air through the hose and into the connectors and nozzles. Blow the nozzles from the sprayer side toward the connector.
 3. Visually check that there is no rust on any of the system components. Replace all rusted components.
 4. Reassemble the system following the instructions provided in section 5.

Special situations:

In the event the vehicle is flooded:

- Disassemble and clean the system as follows:
 1. Disassemble the nozzles from their connectors and the connectors from the hose.
 2. Blow compressed air through the hose and into the connectors and nozzles. Blow the nozzles from the sprayer side toward the connector.
 3. Let the system dry completely and repeat the cleaning with compressed air.
 4. Visually check that there is no rust on any of the system components. Replace all rusted components.
 5. Reassemble the system following the instructions provided in section 5.
- Disassemble the control unit, open the battery compartment, clean it and leave it to dry. Replace the 9V battery that powers the system electrical control.
- Make all checks described in the "before every race" section, except for replacing the battery.

After an accident not involving fire in which the system is not activated:

- make sure that all fastening screws in the system are tight, especially those securing the bottle. If any screw is unfastened, replace it with a new one.
- make sure that the bottle fasteners have not been warped in any way. If there is any deformation, replace the fastening brackets.
- Visually check hose integrity and nozzle orientation. Replace damaged components, if any.
- Perform all checks described in the "before every race" section.

After activation of the system not involving fire:

- have the bottle recharged by OMP or an authorized OMP service center.
- Clean the system as described in the "in the event the vehicle is flooded" section.
- Perform all checks required in the event of an accident not involving fire and in which the system is not activated.

After activation of the system when fire was present:

- have the bottle recharged by OMP or an authorized OMP service center
- replace the protective sleeves on the hoses.
- clean the system as described in the "in the event the vehicle is flooded" section.
- Perform all checks required in the event of an accident not involving fire and in which the system is not activated.

10. WARRANTY

OMP extinguishing systems are guaranteed for a period of 24 months from the date of purchase in accordance with EC Directive 99/44. In countries outside the European Union, the warranty period may be different: in this case the period dictated by the law in the country in which the extinguishing system was purchased will apply.

The warranty allows you to request the free of charge replacement or repair of the extinguishing system by the dealer you purchased the product from when manufacturing defects arisen during the warranty period are not attributable to use not complying with instructions in this instruction manual.

Extinguishing systems with a damaged tamper-proof seal will not be serviced under the warranty, as they will be considered tampered with.

The warranty will be voided in the event that the extinguishing system is used improperly or in case of inappropriate maintenance.



WARNING

Any use of the extinguishing system that deviates from the information provided in this manual voids the warranty and relieves OMP Racing s.r.l. of all responsibilities towards the user.



WARNING

Maintenance on the bottle shall be carried out by OMP or by an authorized OMP service center.

Check on OMP (www.ompracing.it) website to identify the licensee closer to you. Maintenance that deviates from information provided in this manual voids the warranty and relieves OMP Racing s.r.l. of all responsibilities towards the user.



WARNING

Never modify or alter your OMP extinguishing system. Alterations or modifications to the extinguishing system nullify the warranty and increase the risk of injury.

1. INSTALLATION DU SYSTEME D'EXTINCTION / FIRE EXTINGUISHER SYSTEM INSTALLATION

101. INSTALLATION DANS L'HABITACLE / COCKPIT INSTALLATION

- a) Emplacement et orientation du corps
Location and orientation of body
- b) Emplacement et orientation des buses
Location and orientation of nozzles
- c) Précaution à prendre lors de l'installation du système
Special care to take with the installation of the system

E1-1 Installation dans l'habitacle (emplacement et orientation du corps)
Cockpit installation (location and orientation of body)

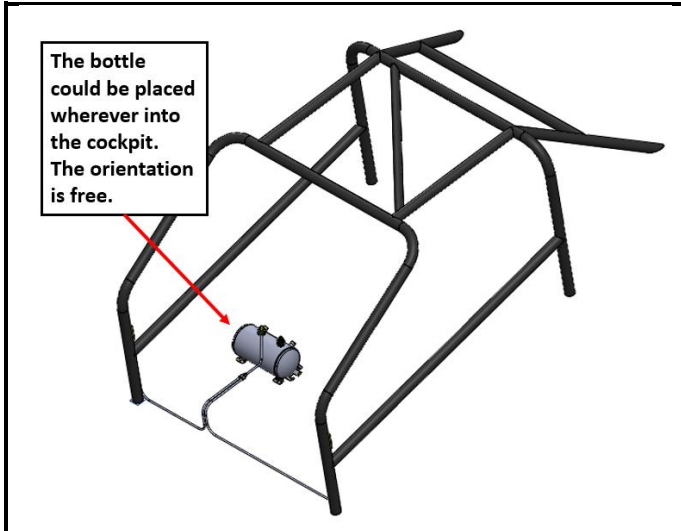

E1-2 Installation dans l'habitacle (emplacement et orientation des buses)
Cockpit installation (location and orientation of nozzles)

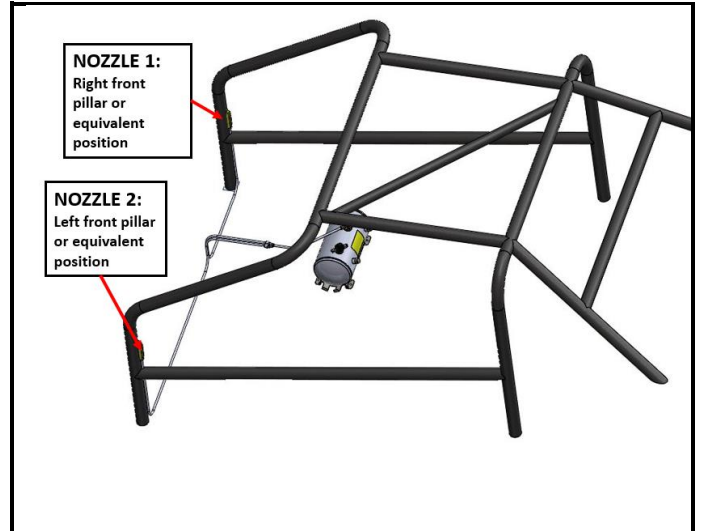

102. INSTALLATION DANS LE MOTEUR / ENGINE INSTALLATION

- a) Emplacement et orientation du corps
Location and orientation of body
- b) Emplacement et orientation des buses
Location and orientation of nozzles
- c) Précaution à prendre lors de l'installation du système
Special care to take with the installation of the system

E2-1 Installation dans le moteur (emplacement et orientation du corps)
Engine installation (location and orientation of body)

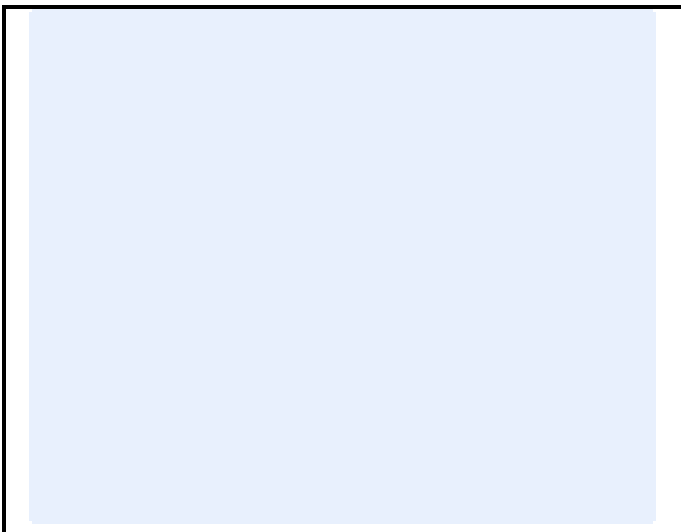

E2-2 Installation dans le moteur (emplacement et orientation des buses)
Engine installation (location and orientation of nozzles)

