



FEDERATION INTERNATIONALE DE L'AUTOMOBILE

Homologation N°

EX.003.15

Date

23.06.2017

**FICHE DE PRESENTATION DES SYSTEMES D'EXTINCTION FIXES (NORME FIA 8865-2015)
PRESENTATION FORM FOR PLUMBED-IN FIRE EXTINGUISHER SYSTEMS (FIA STANDARD 8865-2015)**

1. GENERALITES / GENERAL

101. CONSTRUCTEUR / MANUFACTURER

SPA DESIGN

- a) Adresse
Address **THE MILL HOUSE, PACKINGTON HAYES, LICHFIELD, STAFFORDSHIRE, WS14 9PN, UK**
- b) Téléphone
Phone **+44(0)1543 434580**
- c) E-mail
E-mail **T.TAYLOR@SPA-UK.CO.UK**

102. PHOTO DU SYSTEME COMPLET / PICTURE OF THE COMPLETE SYSTEM



103. MODELE ET TYPE D'AGENT EXTINCTEUR / MODEL AND TYPE OF EXTINGUISHING MEDIUM

- | | | | |
|--|---------------------------------------|----------------------|--|
| a) Modèle
Model | RP-T | | |
| | Habitacle / Moteur
Cockpit/ Engine | Habitacle
Cockpit | Moteur
Engine |
| b) Type d'agent extincteur
Type of extinguishing medium | | Novac 1230 | Novac 1230 / F-500
Encapsulator |

104. PLAGES DE TEMPERATURES ET CLASSIFICATION DES FEUX / TEMPERATURE RANGE AND CLASSIFICATION OF FIRES

Plage de températures
Temperature range

-15 A / To 85 °C

Classification des feux
Classification of fires

- Classe I – Essence conformément à l'Art. 9 de l'Article 252 de l'Annexe J 2014 /
 Class I – Petrol in accordance with Art. 9 of Article 252 of the 2014 Appendix J
- Classe II – Essence + jusqu'à 30% d'éthanol / Class II – Petrol + up to 30% ethanol
 Classe III – Diesel conformément à l'Art. 9 de l'Article 252 de l'Annexe J 2014 /
 Class III – Diesel in accordance with Art. 9 of Article 252 of the 2014 Appendix J
- Classe IV – Ethanol jusqu'à 100% ou méthanol jusqu'à 100% / Class IV – Ethanol up to 100% or Methanol up to 100%
 Classe V – Tout autre carburant spécifique / Class V – Any other specific fuel
 « Specify » E85

2. DETAILS DU SYSTEME / DETAILS OF THE SYSTEM

201. CORPS DE L'APPAREIL / BODY

a) Nombre Number	RP-T		
b) Description Description	Cockpit/engine system (par ex. un corps pour l'habitacle et un autre pour le moteur / e.g. one body for cockpit and another for engine)		
	Habitacle / Moteur Cockpit/ Engine	Habitacle Cockpit	Moteur Engine
c) Matériau Material		aluminium or carbon	aluminium or carbon
d) Diamètre / Longueur [mm] Diameter / Length [mm]	/	127 / 281 or 124 / 281	127 / 281 or 124 / 281
e) Poids sans agent extincteur [kg] Weight without extinguishing medium [kg]		2.001kg or 1.673kg	1.936kg or 1.629kg
f) Poids complet [kg] Complete weight [kg]		4.501kg or 4.173kg	3.616kg or 3.309kg
g) Poids / volume agent extincteur [kg/l] Extinguishing medium weight/volume [kg/l]	/	2.7kg	1kg / 0.680ml

A1) Corps habitacle / moteur 3/4 avant
Cockpit/engine body 3/4 front

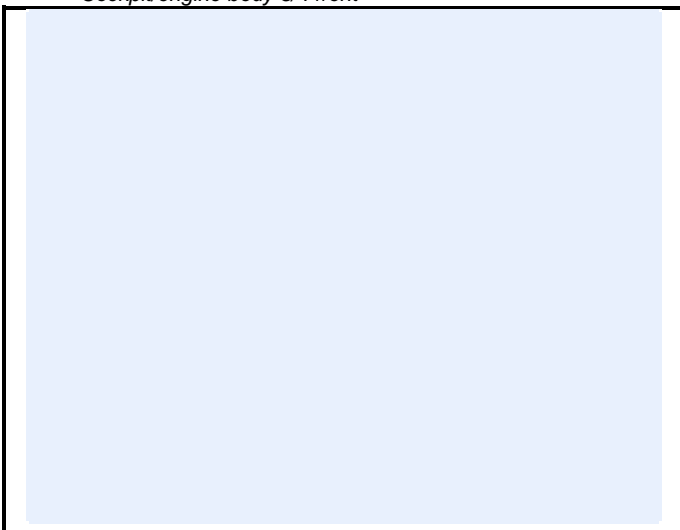

Marque
Make **SPA DESIGN**

Modèle
Model **RP-T**

Homologation N°

EX.003.15

A2) Corps habitacle 3/4 avant
Cockpit body 3/4 front

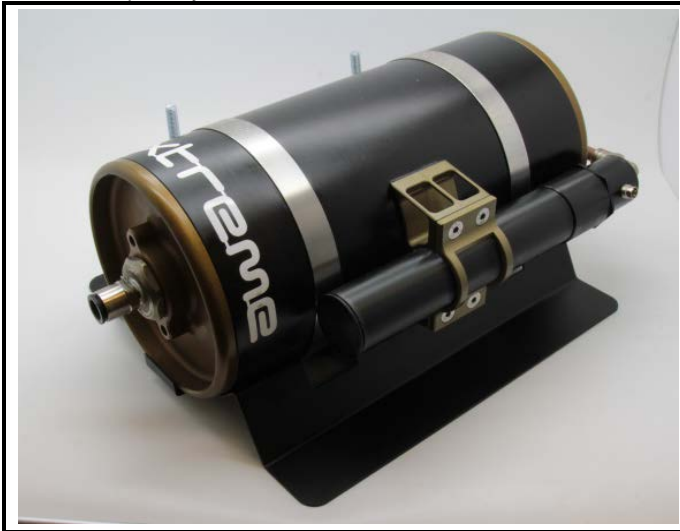

A3) Corps moteur 3/4 avant
Engine body 3/4 front



202. BUSES / NOZZLES

- a) Nombre
Number
- b) Matériau
Material

Habitacle
Cockpit

Moteur
Engine

1

1

aluminium

aluminium

B1-1) Buses habitacle 3/4 avant
Cockpit nozzles 3/4 front



B1-2) Buses moteur 3/4 avant
Engine nozzles 3/4 front



203. TUYAUTERIE / PIPE WORK

- | | | |
|-------------------------------------|----------------------|--------------------------|
| | Habitacle
Cockpit | |
| Oui / Yes | | Non / No |
| <input checked="" type="checkbox"/> | | <input type="checkbox"/> |
| a) Matériau
Material | copper | |

- | | | |
|-------------------------------------|------------------|--------------------------|
| | Moteur
Engine | |
| Oui / Yes | | Non / No |
| <input checked="" type="checkbox"/> | | <input type="checkbox"/> |
| b) Matériau
Material | copper | |

B2-1) Tuyauterie habitacle (dessin avec diamètres des tuyaux)
Cockpit pipework (drawing with tube diameters)

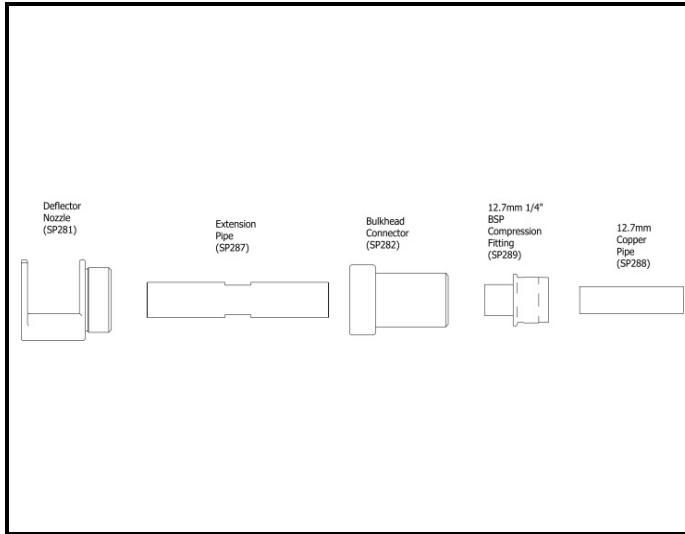

B2-2) Tuyauterie moteur (dessin avec diamètres des tuyaux)
Engine pipework (drawing with tube diameters)

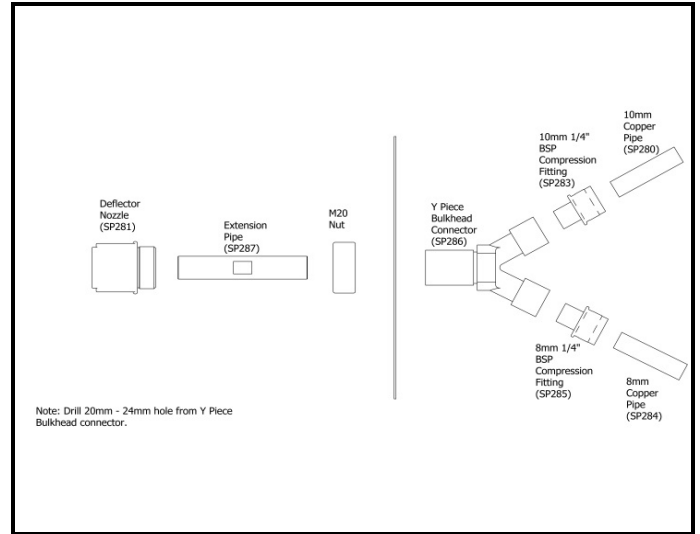

204. ACTIVATION / ACTIVATION

a) Type d'activation
Type of activation

Mécanique <i>Mechanical</i>		Électrique <i>Electrical</i>	
Oui / <i>Yes</i>	Non / <i>No</i>	Oui / <i>Yes</i>	Non / <i>No</i>
<input type="checkbox"/>	<input checked="" type="checkbox"/>	<input checked="" type="checkbox"/>	<input type="checkbox"/>

C1-1) Système d'activation mécanique (système complet)
Mechanical activation system (complete system)

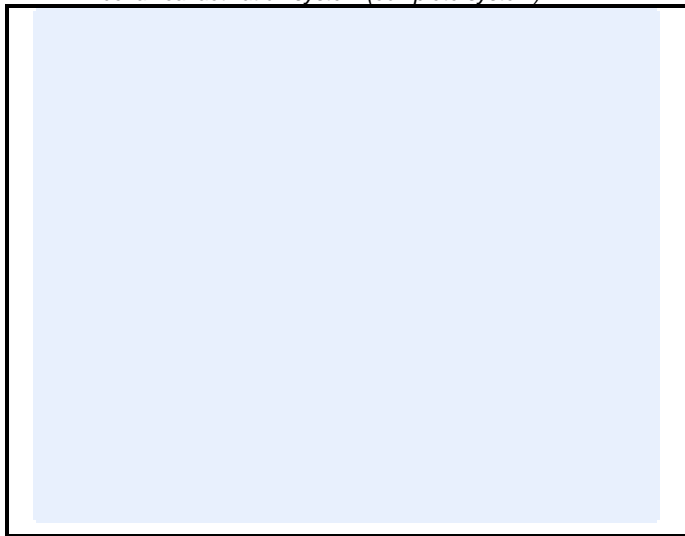

C1-2) Levier de décharge du système d'activation mécanique
Discharge lever of the mechanical activation system



C2-1) Système d'activation électrique (système complet)
Electrical activation system (complete system)

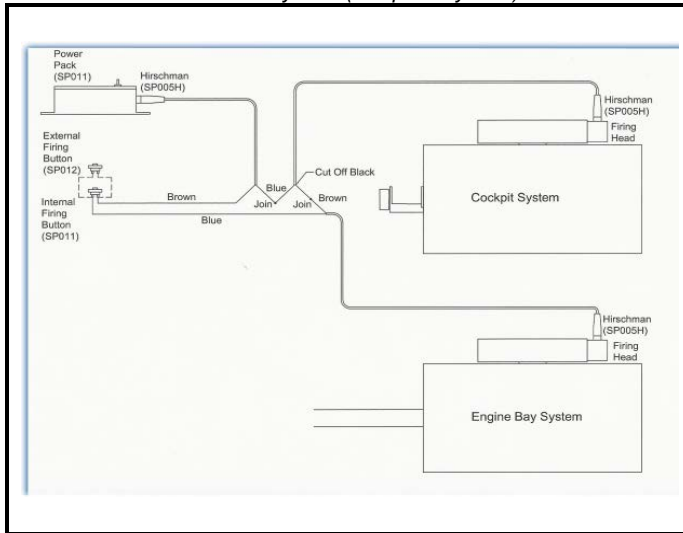

C2-2) Système d'activation électrique (boîtier électrique)
Electrical activation system (electrical box)



3. ETIQUETTES D'HOMOLOGATION ET DE MAINTENANCE / HOMOLOGATION AND MAINTENANCE LABEL

301. ETIQUETTES / LABELS

	Etiquette d'homologation <i>Homologation label</i>	Etiquette de maintenance <i>Maintenance label</i>
a) Dimensions [mm] <i>Dimensions [mm]</i>	94 x 54	94 x 28
b) Couleur du fond de l'étiquette <i>Label background colour</i>	gold	gold

D1-1) Etiquette d'homologation collée sur le corps
Homologation label glued on the body

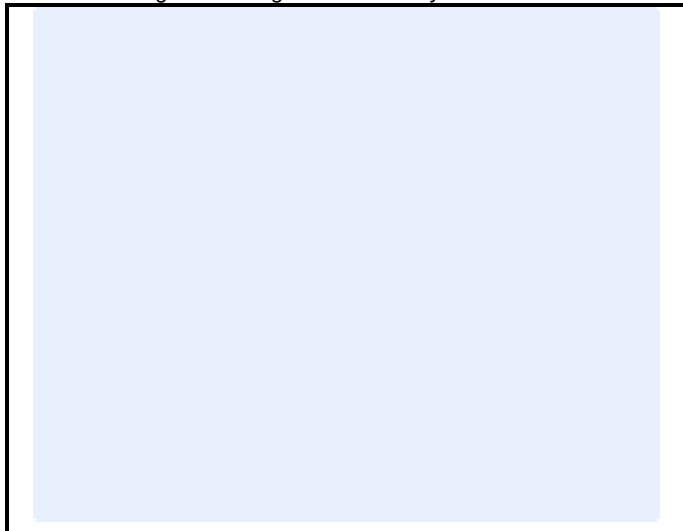

D1-2) Etiquette de maintenance collée sur le corps
Maintenance label glued on the body

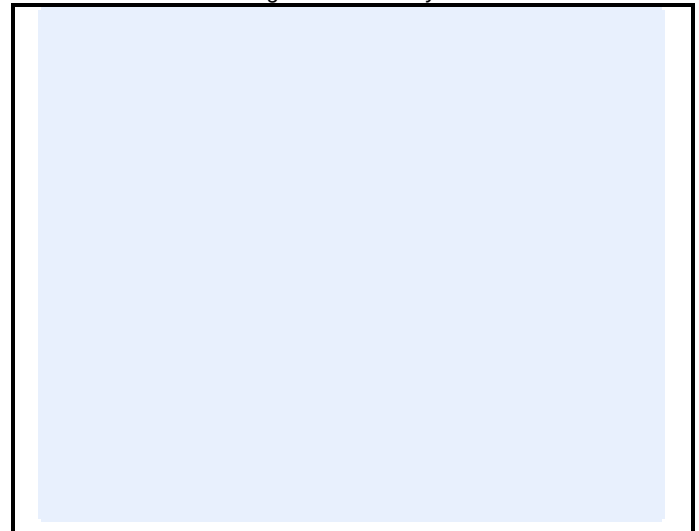

Marque
Make SPA DESIGN

Modèle
Model RP-T

Homologation N°

EX.003.15

INFORMATIONS COMPLEMENTAIRES / COMPLEMENTARY INFORMATION

