



**FEDERATION INTERNATIONALE
DE L'AUTOMOBILE**

Homologation N°

EX.002.15

Date

30.11.2015

**FICHE DE PRESENTATION DES SYSTEMES D'EXTINCTION FIXES (NORME FIA 8865-2015)
PRESENTATION FORM FOR PLUMBED-IN FIRE EXTINGUISHER SYSTEMS (FIA STANDARD 8865-2015)**

1. GENERALITES / GENERAL

101. CONSTRUCTEUR / MANUFACTURER

SPA DESIGN

- a) Adresse
Address THE MILL HOUSE, PACKINGTON HAYES, LICHFIELD, STAFFORDSHIRE, WS14 9PN, UK
- b) Téléphone
Phone +44(0)1543 434580
- c) E-mail
E-mail T.TAYLOR@SPA-UK.CO.UK

102. PHOTO DU SYSTEME COMPLET / PICTURE OF THE COMPLETE SYSTEM



103. MODELE ET TYPE D'AGENT EXTINCTEUR / MODEL AND TYPE OF EXTINGUISHING MEDIUM

- | | | | |
|--|---------------------------------------|----------------------|-------------------|
| a) Modèle
Model | RP-D | | |
| | Habitacle / Moteur
Cockpit/ Engine | Habitacle
Cockpit | Moteur
Engine |
| b) Type d'agent extincteur
Type of extinguishing medium | | Novex 1230 | Novex 1230 |

104. PLAGES DE TEMPERATURES ET CLASSIFICATION DES FEUX / TEMPERATURE RANGE AND CLASSIFICATION OF FIRES

Plage de températures
Temperature range

-15 A / To 85 °C

Classification des feux
Classification of fires

- Classe I – Essence conformément à l'Art. 9 de l'Article 252 de l'Annexe J 2014 /
Class I – Petrol in accordance with Art. 9 of Article 252 of the 2014 Appendix J
- Classe II – Essence + jusqu'à 30% d'éthanol / Class II – Petrol + up to 30% ethanol
- Classe III – Diesel conformément à l'Art. 9 de l'Article 252 de l'Annexe J 2014 /
Class III – Diesel in accordance with Art. 9 of Article 252 of the 2014 Appendix J
- Classe IV – Ethanol jusqu'à 100% ou méthanol jusqu'à 100% / Class IV – Ethanol up to 100% or Methanol up to 100%
- Classe V – Tout autre carburant spécifique / Class V – Any other specific fuel

« Specify »

2. DETAILS DU SYSTEME / DETAILS OF THE SYSTEM

201. CORPS DE L'APPAREIL / BODY

a) Nombre Number	RP-D		
b) Description Description	Cockpit/engine system (par ex. un corps pour l'habitacle et un autre pour le moteur / e.g. one body for cockpit and another for engine)		
	Habitacle / Moteur Cockpit/ Engine	Habitacle Cockpit	Moteur Engine
c) Matériau Material		aluminium or carbon	aluminium or carbon
d) Diamètre / Longueur [mm] Diameter / Length [mm]	/	127 / 281 or 124 / 281	127 / 281 or 124 / 281
e) Poids sans agent extincteur [kg] Weight without extinguishing medium [kg]		2.001kg or 1.673kg	2.001kg or 1.673kg
f) Poids complet [kg] Complete weight [kg]		4.501kg or 4.173kg	4.301kg or 3.973kg
g) Poids / volume agent extincteur [kg/l] Extinguishing medium weight/volume [kg/l]	/	2.7kg	2.5kg

A1) Corps habitacle / moteur 3/4 avant
Cockpit/engine body 3/4 front

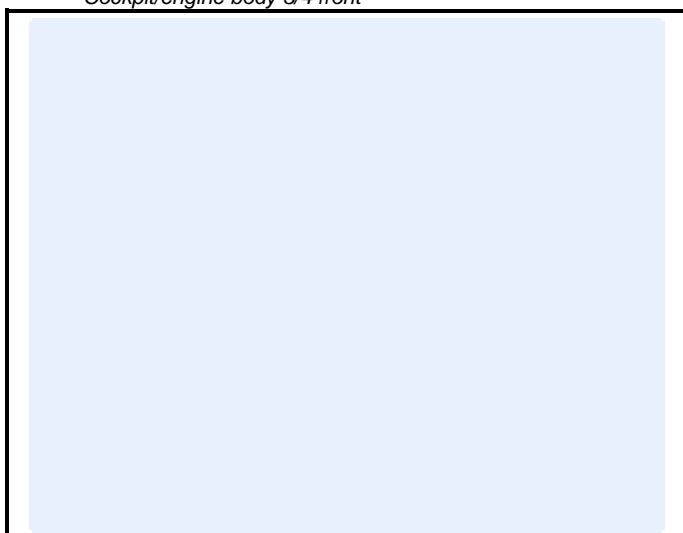

Marque
Make **SPA DESIGN**

Modèle
Model **RP-D**

Homologation N°

EX.002.15

A2) Corps habitacle 3/4 avant
Cockpit body 3/4 front



A3) Corps moteur 3/4 avant
Engine body 3/4 front



202. BUSES / NOZZLES

- a) Nombre
Number
- b) Matériau
Material

Habitacle
Cockpit

Moteur
Engine

1

1

aluminium

aluminium

B1-1) Buses habitacle 3/4 avant
Cockpit nozzles 3/4 front



B1-2) Buses moteur 3/4 avant
Engine nozzles 3/4 front



203. TUYAUTERIE / PIPE WORK

- | | | |
|-------------------------------------|----------------------|--------------------------|
| | Habitacle
Cockpit | |
| Oui / Yes | | Non / No |
| <input checked="" type="checkbox"/> | | <input type="checkbox"/> |
| a) Matériau
Material | copper | |

- | | | |
|-------------------------------------|------------------|--------------------------|
| | Moteur
Engine | |
| Oui / Yes | | Non / No |
| <input checked="" type="checkbox"/> | | <input type="checkbox"/> |
| b) Matériau
Material | copper | |

Marque
Make

SPA DESIGN

Modèle
Model

RP-D

Homologation N°

EX.002.15

B2-1) Tuyauterie habitacle (dessin avec diamètres des tuyaux)
Cockpit pipework (drawing with tube diameters)

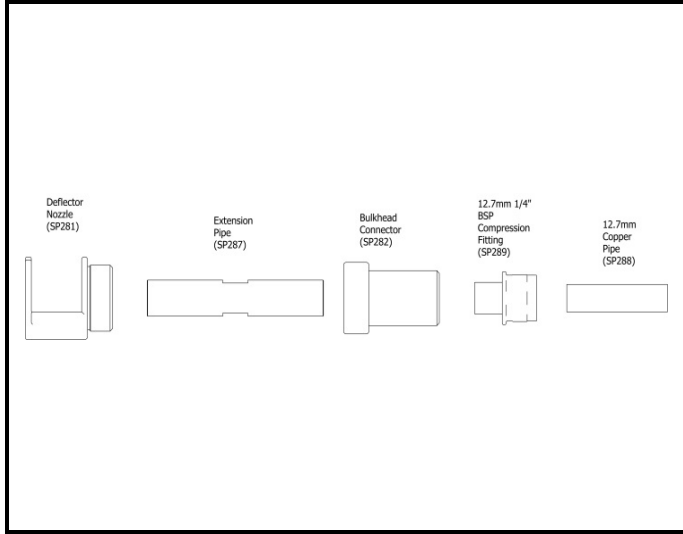

B2-2) Tuyauterie moteur (dessin avec diamètres des tuyaux)
Engine pipework (drawing with tube diameters)

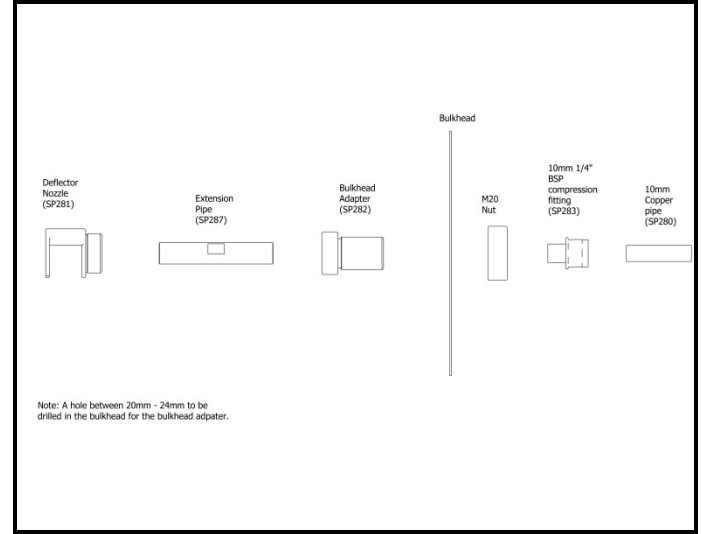

204. ACTIVATION / ACTIVATION

a) Type d'activation
Type of activation

Mécanique
Mechanical
Oui / Yes Non / No

Électrique
Electrical
Oui / Yes Non / No

C1-1) Système d'activation mécanique (système complet)
Mechanical activation system (complete system)



C1-2) Levier de décharge du système d'activation mécanique
Discharge lever of the mechanical activation system



C2-1) Système d'activation électrique (système complet)
Electrical activation system (complete system)

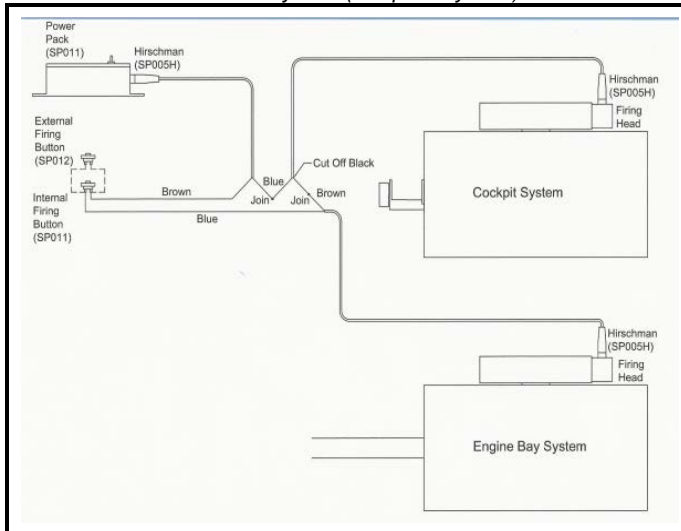

C2-2) Système d'activation électrique (boîtier électrique)
Electrical activation system (electrical box)



3. ETIQUETTES D'HOMOLOGATION ET DE MAINTENANCE / HOMOLOGATION AND MAINTENANCE LABEL

301. ETIQUETTES / LABELS

	Etiquette d'homologation <i>Homologation label</i>	Etiquette de maintenance <i>Maintenance label</i>
a) Dimensions [mm] <i>Dimensions [mm]</i>	94 x 54	94 x 28
b) Couleur du fond de l'étiquette <i>Label background colour</i>	silver	silver

D1-1) Etiquette d'homologation collée sur le corps
Homologation label glued on the body

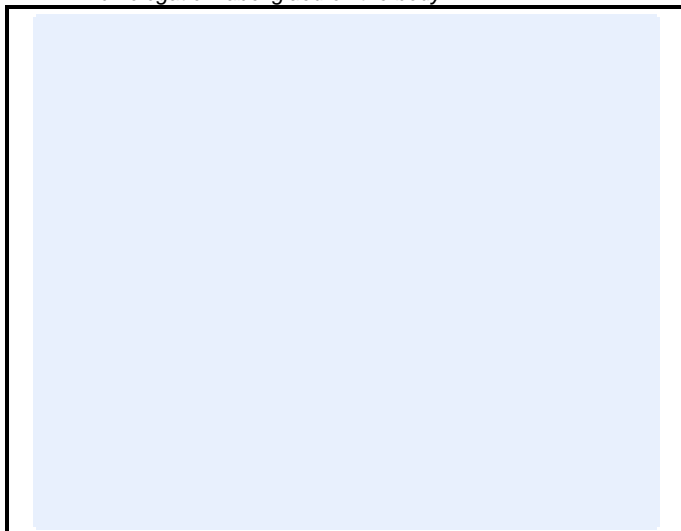

D1-2) Etiquette de maintenance collée sur le corps
Maintenance label glued on the body

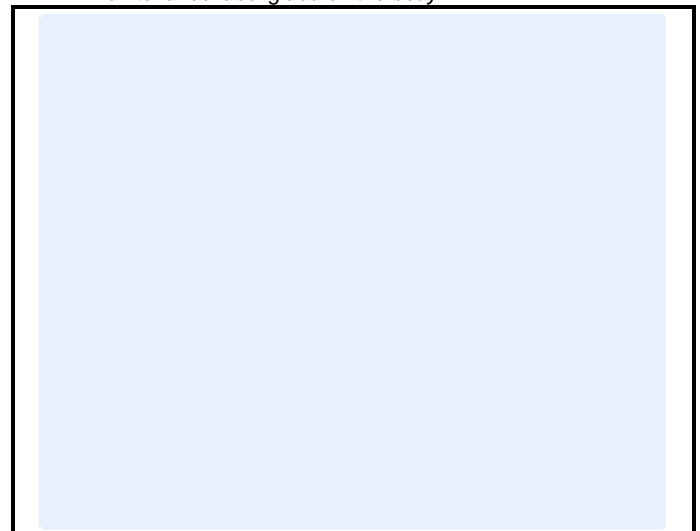

Marque
Make

SPA DESIGN

Modèle
Model

RP-D

Homologation N°

EX.002.15

INFORMATIONS COMPLEMENTAIRES / COMPLEMENTARY INFORMATION

