

SPA DESIGN



Fire Suppression manual for RP-D

Advanced Propulsion Systems (A.P.S)

Thank you for purchasing one of our latest range of systems **Homologated to the latest FIA standard 8865-2015**. *This manual covers the following systems RP-D*

It is important that you read the following instructions carefully before attempting to install your fire suppression systems.

The performance of these systems could be affected if they are in any way modified or tampered with and will void its homologation. Please ensure you only use genuine SPA parts should any part need replacing.

Should you require assistance with this please call +44(0)1543 434580 or email sales@spa-uk.co.uk

| Index | Pages |
|------------------------------------|--------------|
| Contents | 2-3 |
| System fitting instructions | 4 |
| Electrical installation | 5-6 |
| Engine bay/cockpit nozzle location | 7-11 |
| Connecting Copper pipe | 12 |
| System pictures | 13-14 |
| Bottle dimensions | 15-16 |
| Data sheets | 17 |
| Installation Notes | 18 |

CONTENTS

2

RP-D ENGINE SYSTEM

- 1 X SPA-EX-E-APS-B BOTTLE ONLY
- 1 X SP278 BOTTLE PLINTH
- 2 X SP279 BOLTED STRAPS
- 2 X SP280 10MM COPPER PIPE PER METER
- 1 X SP281 DEFLECTOR NOZZLE
- 1 X SP282 BULKHEAD CONNECTOR ¼ BSP-M20
- 1 X SP283 10mm ¼ BSP COMPRESSION FITTING

CONTENTS

RP-D COCKPIT SYSTEM

- 1 X SPA-eX-APS-B BOTTLE ONLY
- 1 X SP278 BOTTLE PLINTH
- 2 X SP279 BOLTED STRAPS
- 1 X SP281 DEFLECTOR NOZZLE
- 1 X SP288 ½ METER 12.7MM COPPER PIPE
- 1 X SP282 BULKHEAD CONNECTOR ¼ BSP-M20
- 1 X SP287 EXTENSION PIPE
- 1 X SP289 12.7MM ¼ BSP COMPRESSION FITTING

ELECTRICAL KIT

3 X SP005H HIRSCHMAN PLUG & LEADS

1 X SP277 NEW FIA STANDARD POWER PACK HIRSCHMAN TYPE

1 x SP011 INTERNAL FIRE BUTTON

1 X SP012 EXTERNAL FIRE BUTTON

1 X SP017 E LOCATION STICKER LARGE

1 X SP129 E LOCATION STICKER SMALL

SYSTEM FITTING INSTRUCTIONS

Unpack all parts and check components against check list on pages 2 & 3.

Mount the engine bay system in or around the passenger footwell ideally in a transverse position pages 7-11

Mount the cockpit system ideally as detailed on pages 7-11 behind driver or passenger seat.

The extinguisher label, detailing contents etc. should be visible, mount the plinth securely to the vehicle and secure the bottle with the straps provided.

Mount the power pack in a clearly visible position.

Switch with Shroud (SP011) to be fitted in the cockpit within easy reach of both driver and co-driver when sitting in normal driving position and wearing fastened seatbelts.

External switch (SP012) to be fitted to outside of vehicle, close to master switch (to activate by marshals when required).

Electrical system to be wired as shown on page 6.

ELECTRICAL SYSTEM FITTING & TEST INSTRUCTIONS



TEST POSITION

With the switch in the test position, the power pack is not armed and draws no current until either the internal switch (SP011) or external switch (SP012) is pressed.

To initiate the test routine, press either internal or external switch.

Test all good

If all the tests are good, then the amber test lamp will light for 6 seconds and then go off. **This means that the system has not been operated and the Co2 canister is still charged and all wiring continuity is good.**

Test failed

If one of the tests fails, the amber light will flash the fault indication for 12 seconds and go off.

Fault Indication

If the amber test lamp flashes one pulse at a time, this is error 1 = low battery

If the amber test lamp flashes two pulses at a time, this is error 2 = Continuity Ohms too high

If there is a short in the wiring or if the firing button is not released, then the amber light will change from good (no flashing) to error (flashing error 3) after 6 seconds.

If the amber test lamp flashes three pulses at a time, this is error 3 = short circuit

Warning error 3 will continue to flash until the fault is removed – DO NOT switch system to armed if error 3 is flashing as this may operate the fire suppression systems, you must locate the fault in the wiring harness or switches.

If no lights come on when you press the button, then there is no continuity. This can be due to a loom fault, a switch fault, an expended firing head, incorrect wiring, firing head not plugged in or a flat battery (check the battery by disconnecting the loom and momentarily switching to Armed position).

ARMED POSITION With the switch in armed position, the power pack is providing full battery power to the output socket. If power pack switch and the battery volts are good, then the **Red Armed LED** will flash constantly. The Red LED only uses a very small amount of power; **the battery should be replaced every 6 months to ensure the power pack battery is in the best condition**

2 SYSTEM WIRING

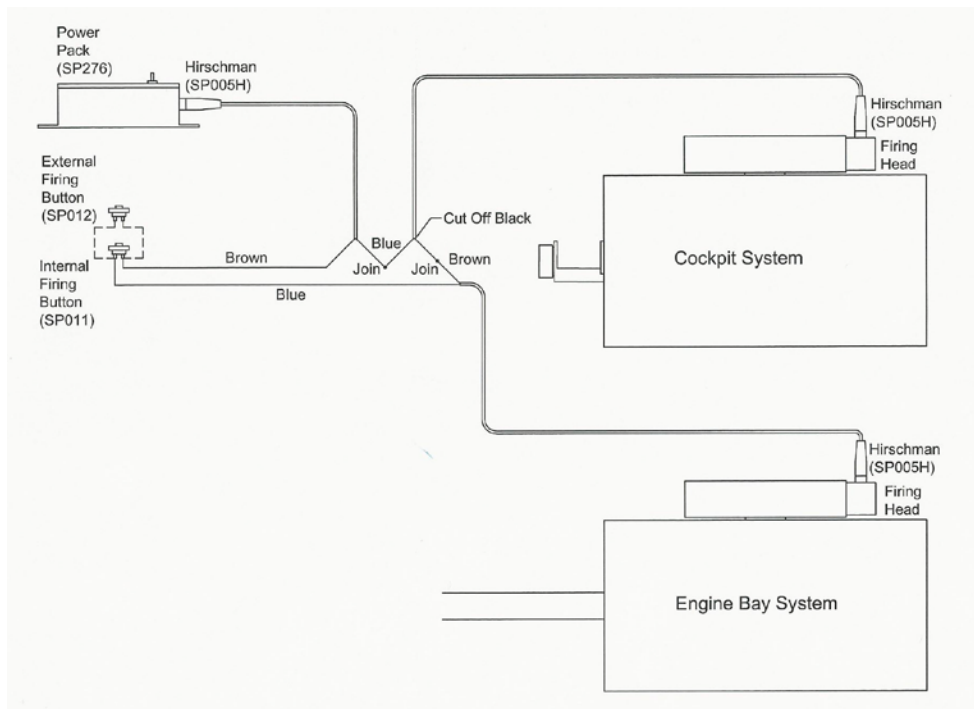

SINGLE SYSTEM WIRING

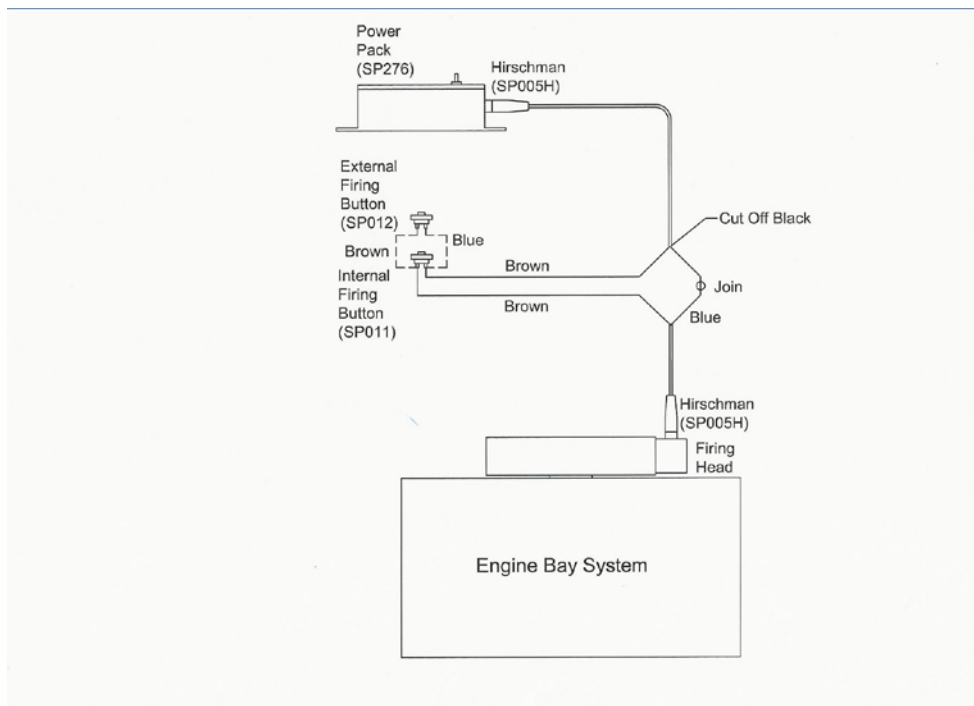

1. INSTALLATION DU SYSTEME D'EXTINCTION / FIRE EXTINGUISHER SYSTEM INSTALLATION

101. INSTALLATION DANS L'HABITACLE / COCKPIT INSTALLATION

- Emplacement et orientation du corps
Location and orientation of body
- Emplacement et orientation des buses
Location and orientation of nozzles
- Précaution à prendre lors de l'installation du système
Special care to take with the installation of the system

E1-1) Installation dans l'habitacle (emplacement et orientation du corps)
Cockpit installation (location and orientation of body)

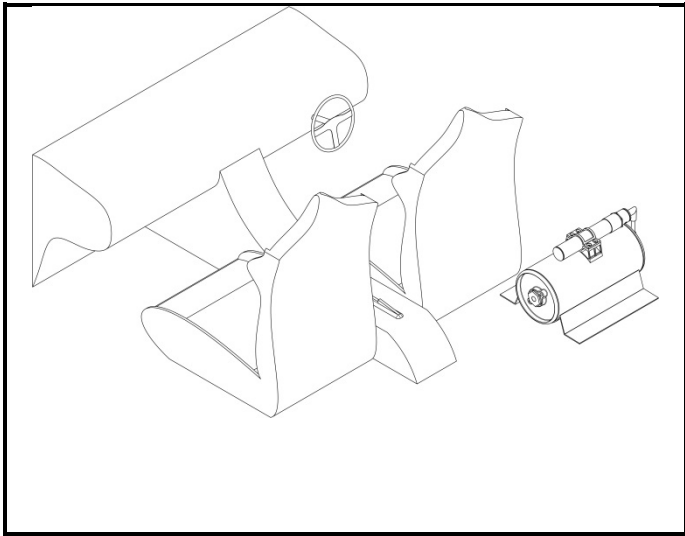

Horizontally mounted behind driver or passenger seat

Located between driver and passenger seat

Important do not obstruct the nozzle especially the space above it as the gas needs to reach the roof of the vehicle.

E1-2) Installation dans l'habitacle (emplacement et orientation des buses)
Cockpit installation (location and orientation of nozzles)

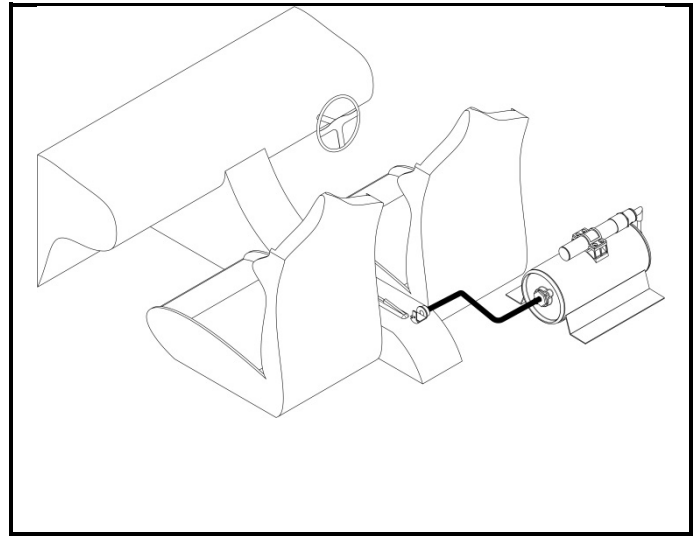

102. INSTALLATION DANS LE MOTEUR / ENGINE INSTALLATION

- Emplacement et orientation du corps
Location and orientation of body
- Emplacement et orientation des buses
Location and orientation of nozzles
- Précaution à prendre lors de l'installation du système
Special care to take with the installation of the system

E2-1) Installation dans le moteur (emplacement et orientation du corps)
Engine installation (location and orientation of body)

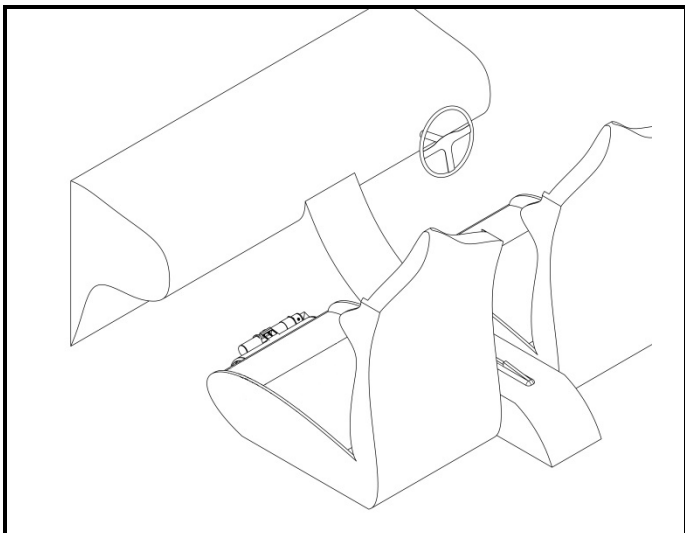

Horizontally mounted, behind driver or co-driver seat or in front of driver or co-driver seat.

Mount off bulkhead central to engine.

Ensure all fittings are secure.

E2-2) Installation dans le moteur (emplacement et orientation des buses)
Engine installation (location and orientation of nozzles)

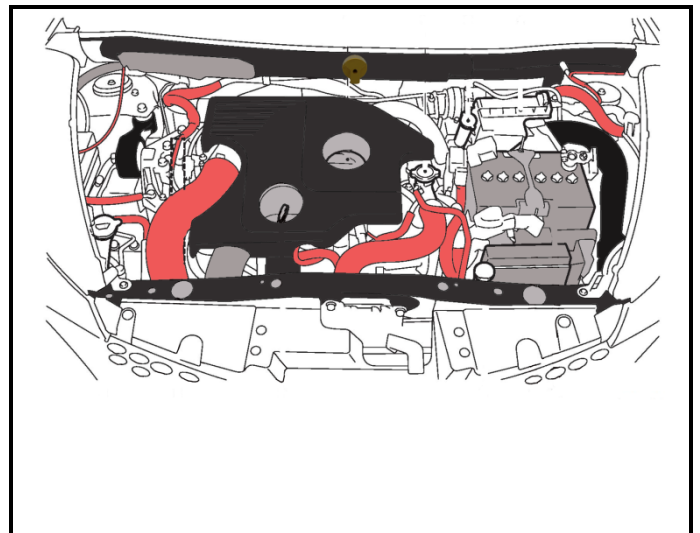

ENGINE NOZZLE LOCATION

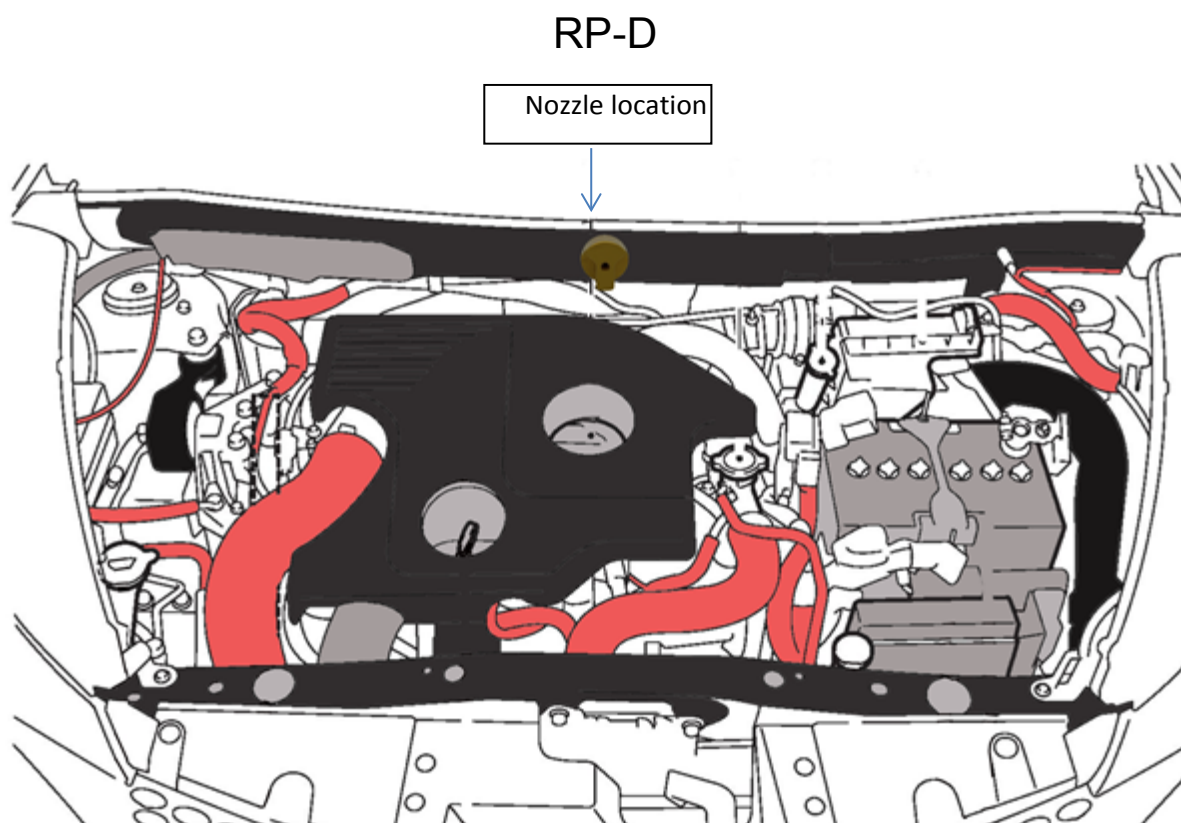

BOTTLE LOCATION ENGINE

Ideally mount bottle in passenger footwell area

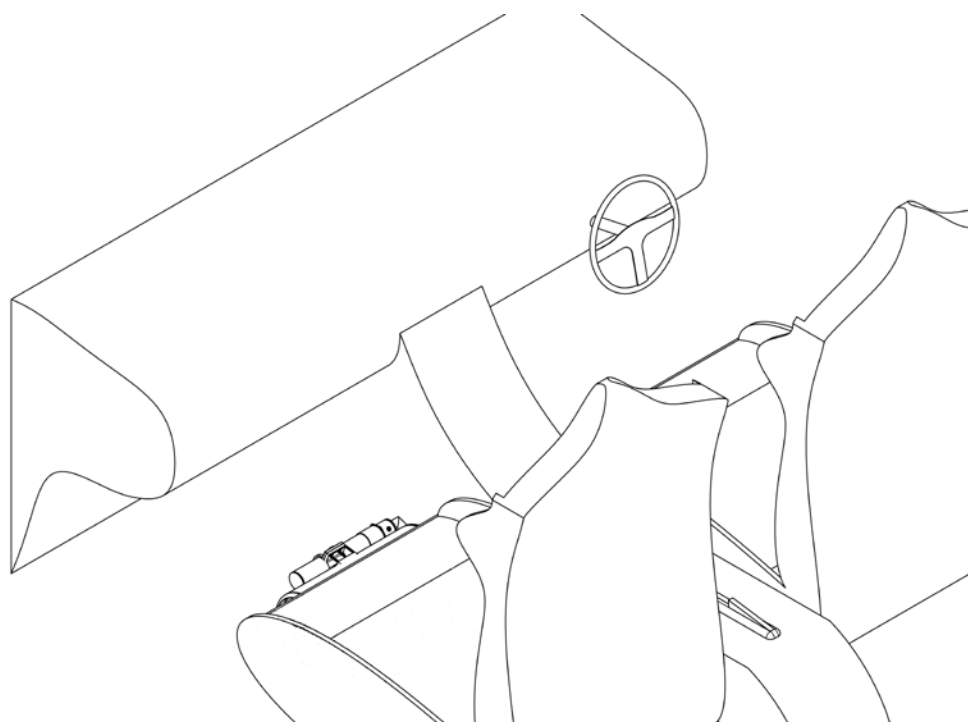

DEFLECTOR NOZZLE ORIENTATION ENGINE BAY

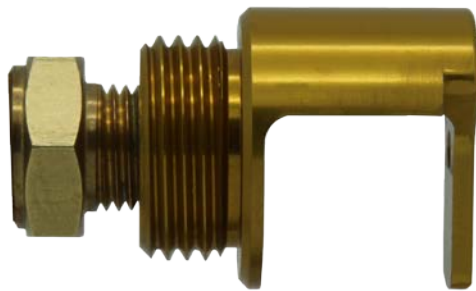

COCKPIT NOZZLE LOCATION

RP-D

Nozzle location

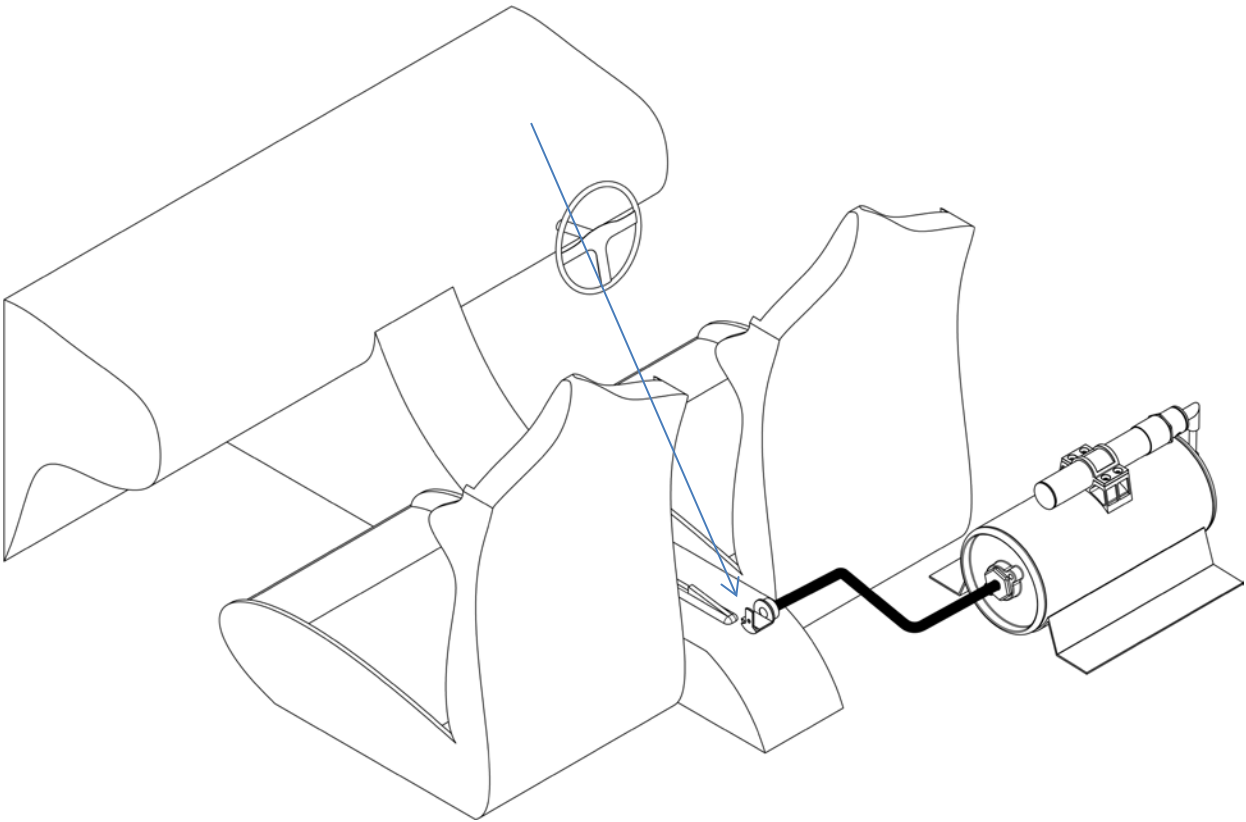

Ideally mount cockpit bottle either behind driver seat or passenger seat

ENGINE BAY NOZZLE CONNECTIONS

SINGLE OUTLET RP-D

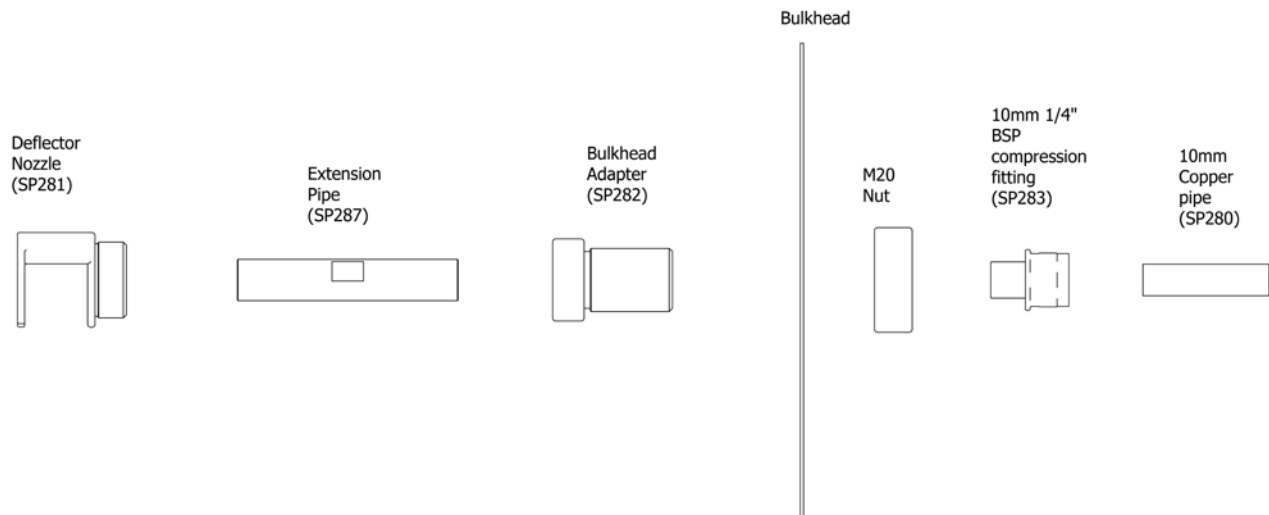

Note: A hole between 20mm - 24mm to be drilled in the bulkhead for the bulkhead adapter.

The engine bay Nozzle comes preassembled.

1. Measure length of pipe required, cut to size using pipe cutter or hacksaw, deburr pipe.
2. Push one end of pipe into 10mm fitting on bottle.
3. Make 21mm hole in bulkhead.
4. Insert bulkhead Fitting into hole from engine bay side
5. Keep Deflector nozzle in position as shown on page 8
6. Turn M20 nut onto bulkhead Fitting until tight against bulkhead
7. Screw ¼ BSP compression fitting into bulkhead connector until tight
8. Place Compression nut and then olive onto 10mm pipe
9. Insert pipe into compression fitting and tighten using two spanners

CONNECTING COPPER PIPE – COMPRESSION FITTINGS

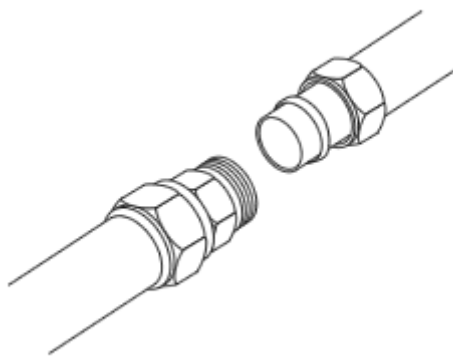

Once the pipes have been cut square – make sure all components are clean; you can use steel wool for this.

Place the first nut over one of the sections of pipe.

Next, place the olive over the pipe and push it along a little. Some olives have a right and wrong way round. If this is the case, they will have a different size chamfer on each side. The longest one goes against the middle of the joint.

Place the fitting over the pipe and push it home. Line up the nut and hand-tighten.

Using two spanners, hold the body of the fitting still with one, whilst tightening the nut with the other. It is important to tighten this nut by the right amount. If it is not fully tightened, the joint could leak.

If the nut is over tightened, the olive and pipe can become distorted and the connection will leak. As a guide, the nut will usually require one complete revolution in addition to the hand-tightening. As the spanner is turned, you will feel some obvious resistance as the olive is pushed against the pipe. At this point, it will only need a little additional tightening to become watertight.

This routine is to be applied to all compression fittings where pipework is connected.

SYSTEM IMAGES

COCKPIT SYSTEM

RP-D



RP-D

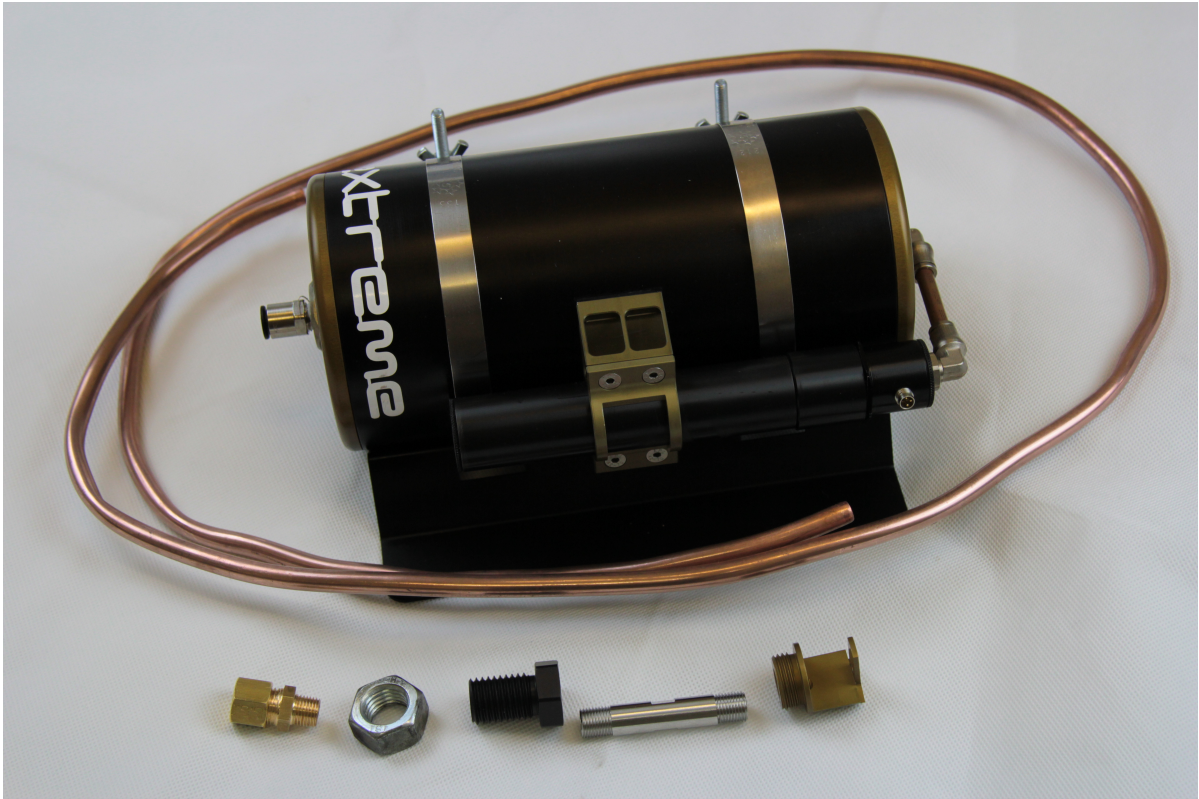

BOTTLE DIMENSIONS ALUMINIUM BOTTLE

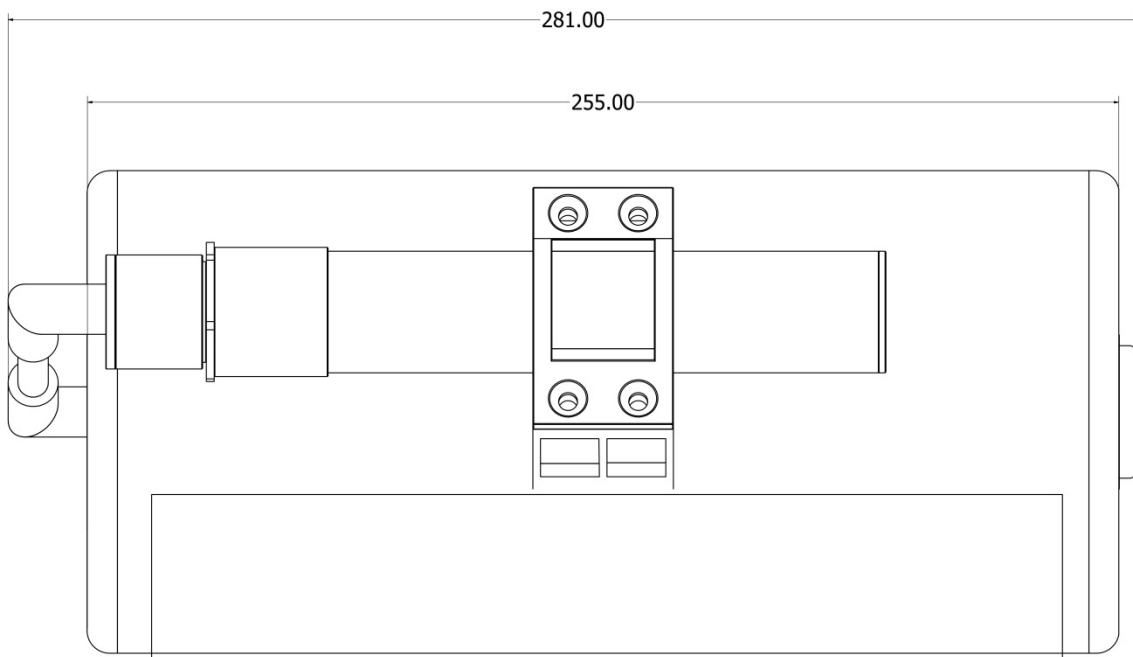
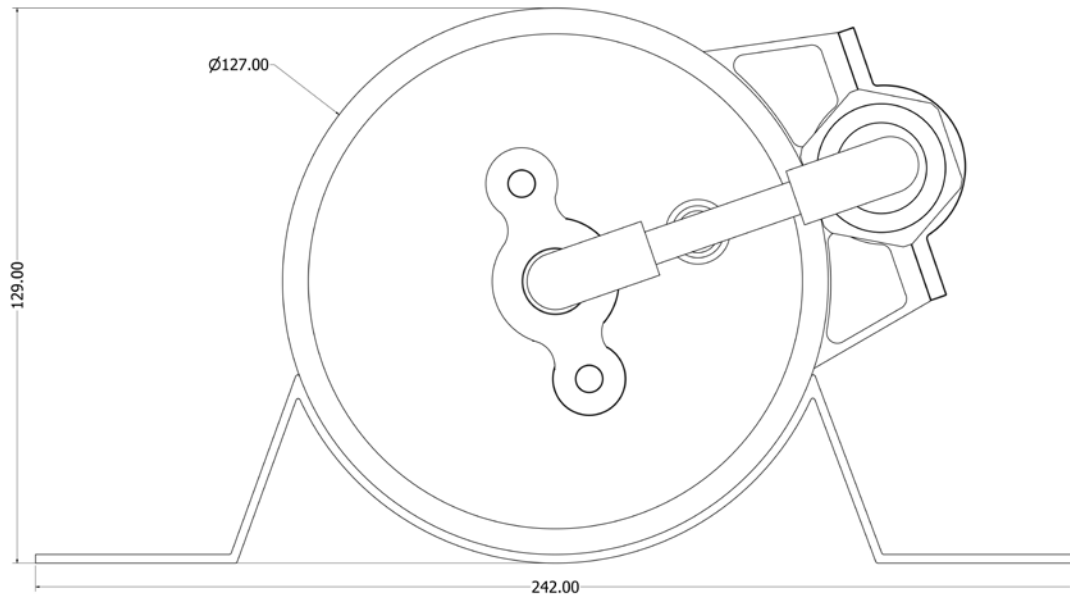

BOTTLE DIMENSIONS CARBON BOTTLE

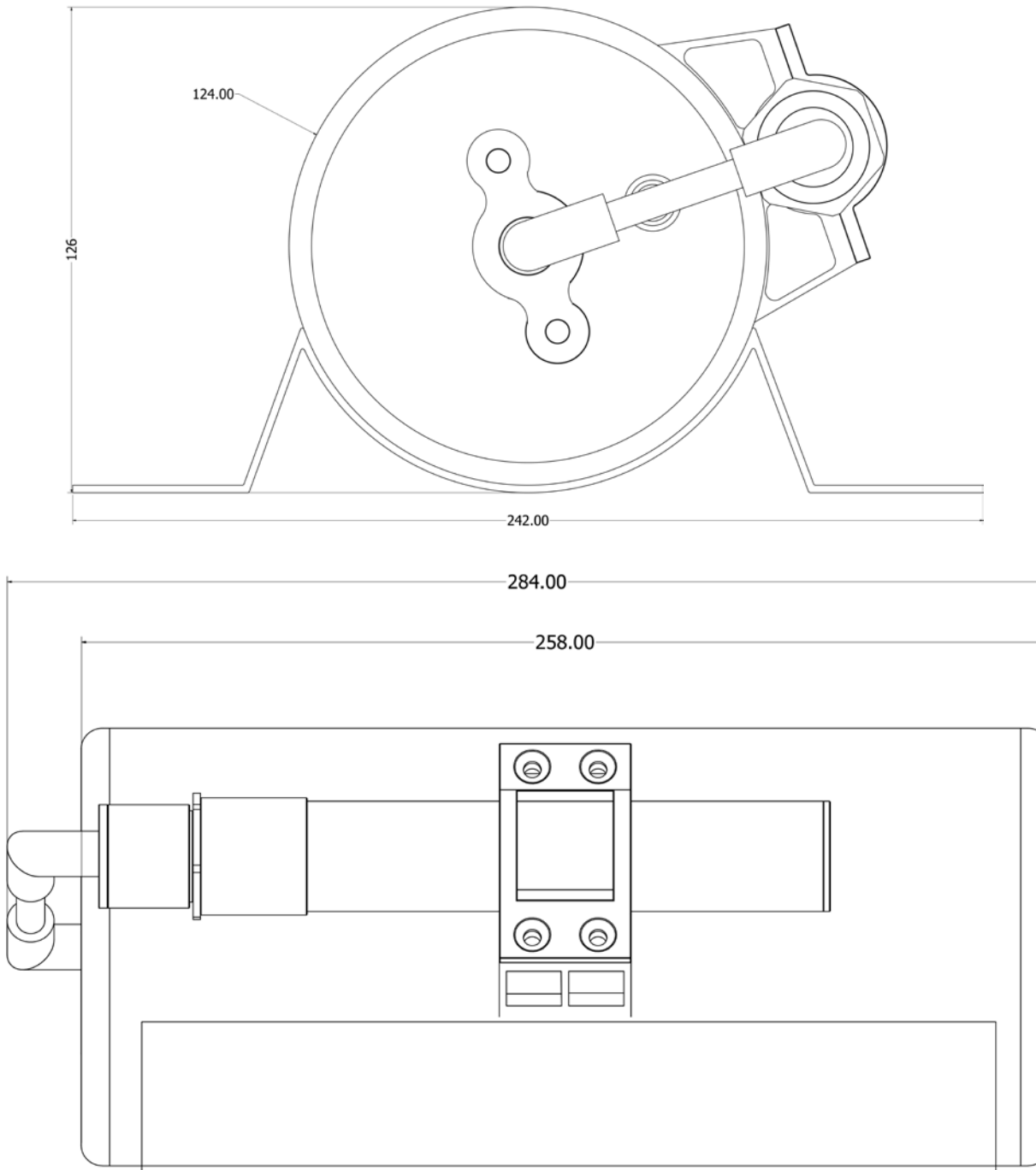

Data sheets

EXTREME

| | |
|---|--|
| Composition (CF ₃ CF ₂ C(O)CF(CF ₃) ₂) | Dodecafluoro-2-methylpentan-3-one, |
| Ozone depletion | None |
| Operating temperature | -40 to + 85 C |
| Freeze point | -108 C |
| Critical temperature | 168.7 C |
| Physiological properties | no observed adverse effect level and lowest observed adverse effect level for cardiac sensitization (halocarbons) and oxygen depletion (Inert gas) |

INSTALLATION NOTES

fig 1

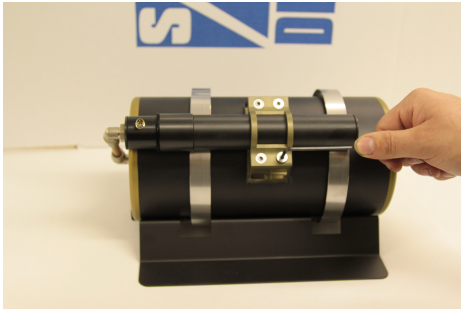

When removing straps on the cockpit systems and single outlet systems for the engine it may be necessary to rotate the charge cylinder for ease of fitments. Remove the four Allen bolts from the bracket and put in a safe place. Fig 1

fig 2



Gently lift the charge cylinder out of the bracket and rotate to the left, it will rotate around the fitting as shown in Fig 2 & 3.

fig 3

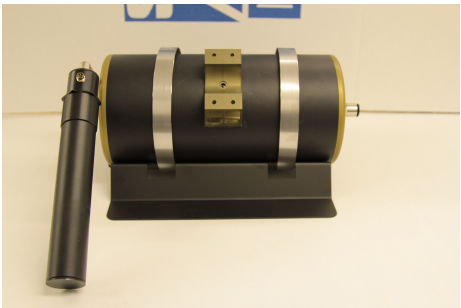

You may now adjust the straps or remove the bottle from the mounting plinth Fig 3. Please remember to replace the top mounting bracket and Allen bolts

fig 4

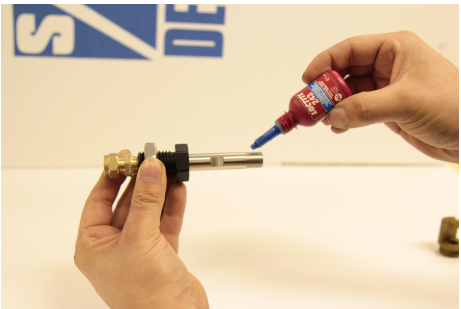

Nozzle installation, install the bulkhead fitting as shown on page 11, apply a small amount of Loctite 243 or equivalent threadlocking medium strength adhesive to prevent vibration Fig 4.

fig 5



Now rotate the nozzle into the correct position as shown on page 8 or 9 and allow threadlocking adhesive to cure as shown in Fig 5