

**Sabelt<sup>®</sup>**

**Sab** *life*

## **FITTING INSTRUCTIONS**

All FIA & MSA Approved Systems

PLEASE READ CAREFULLY BEFORE ATTEMPTING TO INSTALL YOUR SYSTEM

Thank you for purchasing a Sabelt SabLife fire system. It is important that you read these instructions carefully before attempting to install your extinguisher system.

The system should in no way be modified or tampered with as by doing so you could seriously affect its performance. If you need to replace parts, only genuine Lifeline components should be used.

Please retain this installation manual for future reference.

Should you experience any difficulties installing your system, please do not hesitate to contact Sabelt at:



**Sabelt S.p.A.**

Via Guido Rossa, 10  
Moncalieri (TO) ITALY

Tel: +39 (0) 11 6477899 Fax: +39 (0) 11 6477999

Website: [www.sabelt.com](http://www.sabelt.com)

Email: [info@sabelt.com](mailto:info@sabelt.com)

### **IMPORTANT NOTE**

The purpose of any vehicle fire protection system is to provide a time envelope in which to control the fire in order to accomplish evacuation of the occupants. Ideally, the fire will be totally extinguished, but this cannot be guaranteed. Holding back the intensity of an engine or a cockpit fire to enable the occupants to evacuate or allow outside assistance to be given, is the main purpose.

Sabelt S.p.A. endeavours to provide the most accurate and up to date information for its products and reserves the right to amend specifications without notice.  
E & OE.

# CONTENTS

## Page No.

4	FIA Systems covered by these instructions
6	Fitting Instructions – SabLife Systems
6	Mechanical Systems
7	Electrical Systems
8	Wiring Diagram
9	Nozzles & Locations
10	Tubing & Connection
11	Kit Contents
13	Technical Specification
14	Maintenance
15	Annex – Systems Schematic Diagrams

## FIA Systems Covered in these Instructions

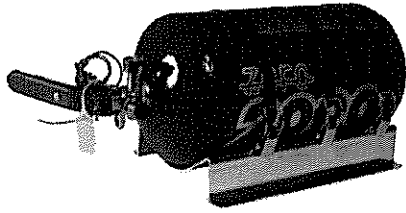

LL102-400-001 EX.002.98  
4.0 litre Fire Marshal Mechanical (Steel Cylinder)  
LL102-400-002  
4.0 litre Fire Marshal Mechanical (Alloy Cylinder)

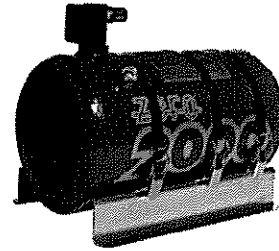

LL102-400-003 EX.002.98  
4.0 litre Electric (Alloy Cylinder)  
LL102-400-007 EX.002.98  
4.0 litre Electric (Steel Cylinder)

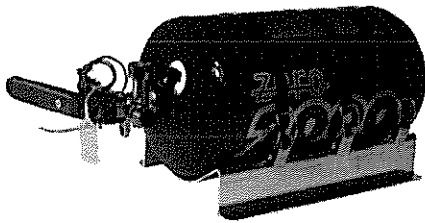

LL101-337-001  
3.375 litre Fire Marshal Flow Control Mechanical

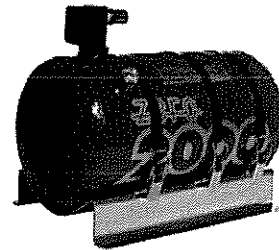

LL101-337-004  
3.375 litre Electric Flow Control - Saloon Car  
LL101-337-005  
3.375 litre Electric Flow Control - Formula Car

# FITTING INSTRUCTIONS - SabLife Systems

Unpack the kit carefully and check that all components are complete. Lay out the components so that each may be identified.

See page 10 for kit component listings.

Remove the extinguisher from its mounting brackets by undoing the over-centre clips. Decide upon the best position for the extinguisher to be mounted bearing in mind that the extinguisher label, showing its contents etc should be clearly visible. The brackets for the extinguisher system should be bolted to the vehicle so that the cylinder is in a transverse orientation and where applicable the extinguisher cylinder is within the safety structure.

## Mechanical Systems

Mechanical systems are operated using pull cables. Each system is supplied with two cables, one being 6ft in length, and depending on system specification either another 6ft cable or a 12ft length cable. Decide upon the best position for the pull cables to be mounted, bearing in mind that the cable mounted in the cockpit should be accessible to the driver and/or co-driver when seated in the normal driving position, and wearing fully fastened seat belts. The external pull cable is normally mounted on the front scuttle of a saloon car (below windscreen) adjacent to the circuit breaker, or by the roll hoop on a single seater or open top vehicle. When installing the pull cable on a saloon car ensure that you leave sufficient clearance for the bonnet to fully open.

The pull cables should be routed so that there are no sharp bends or S shapes in the cable thus ensuring easy operation of the cables. The end of each cable should be passed through the levers of the extinguisher head and secured using the cable clamps attached to the end of the cables. It is advisable to leave a small amount of slack in the cable to prevent accidental firing of the extinguisher. It is recommended that the cables are periodically lubricated to prevent seizure and checked for smooth operation. Please remember to disconnect cables at the discharge head when carrying out these maintenance operations and to reconnect afterwards. The large 'E' decal must be clearly displayed next to the pull release.

## Mechanical Discharge Head Detail

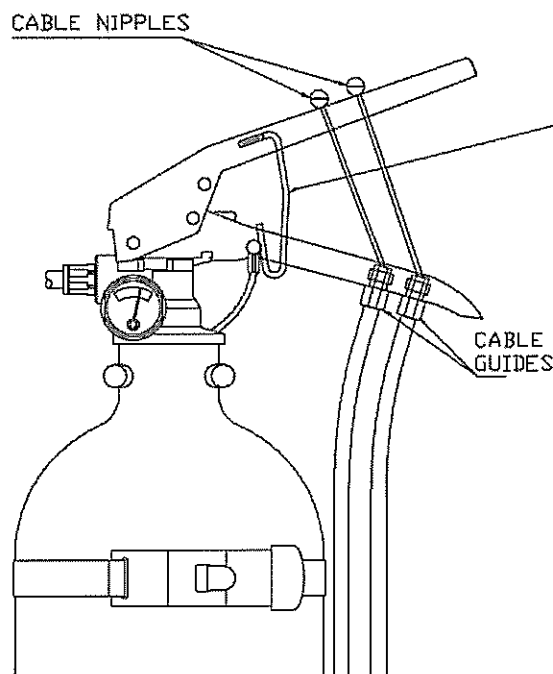

## Electrical Systems

Mount the power pack so that it is clearly visible. Mount the switches to the vehicle. The cockpit switch should then be mounted so that it is within easy reach of the driver and/or co-driver when sitting in the normal position and wearing fully fastened seat belts. Where supplied the external waterproof switch is normally mounted on the front scuttle of a saloon car (below windscreen) adjacent to the circuit breaker, or by the roll hoop on a single seater or open top vehicle. The large 'E' decal must be clearly displayed next to the external switch.

## Wiring of System

See wiring diagram on page 13.

All Sabelt SabLife electrical extinguisher kits have a separate power pack unit to provide the current needed to operate the system. The power pack should be wired independently from the vehicle's electrics as failure to do this may result in the actuation of the system due to electrical interference from the vehicle's power source. Please ensure that all wiring connections are insulated. Heat shrink sleeving is recommended.

Once the system has been wired in accordance with the wiring diagram, a test check should be carried out to ensure that the system will fire properly. Before you start the check procedure, ensure that the bottle and the power pack are connected.

On top of the power pack is a 3-position switch. This provides checking facilities for the battery and wiring. If the switch is pulled down against its spring, the amber LED will light if there is sufficient current in the battery. IF THE AMBER LED DOES NOT LIGHT, OR IMMEDIATELY GOES OUT, THE BATTERY SHOULD BE REPLACED. THE BATTERY SHOULD BE OF THE MAGANESE/ALKALINE LONG LIFE TYPE ONLY, TYPE PP3. Sabelt recommends that the battery be replaced regularly.

With the switch in the centre 'SYSTEM ISOLATED' position, and the centre position only, the wiring of the circuit can be checked. With the extinguisher connected, press each of the firing buttons in turn and the green LED should light. If it does not light there is a break in the circuit. If the green LED lights before the switch is pressed, there is a short in the circuit and the system is permanently 'live'. If this occurs DO NOT PUT THE SWITCH INTO THE 'SYSTEM ARMED' POSITION, OR YOU WILL DISCHARGE THE SYSTEM.

If for any reason the green LED does not illuminate when the system is tested, check the wiring against the wiring diagram shown on page 8. If the problem persists, consult Sabelt.

To arm the system place the switch in to the up 'SYSTEM ARMED' position. The red LED will illuminate to indicate the system is armed.

To prolong battery life and prevent accidental activation, it is recommended that the power pack switch be in the centre 'SYSTEM ISOLATED' position and the plug disconnected when the vehicle is not being used.

## Power Pack

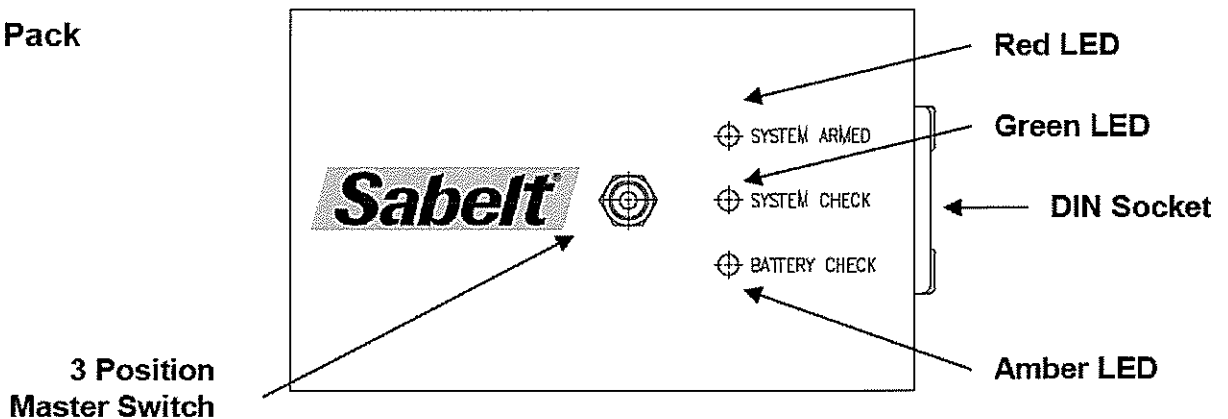

# Electrical Systems Wiring Diagrams

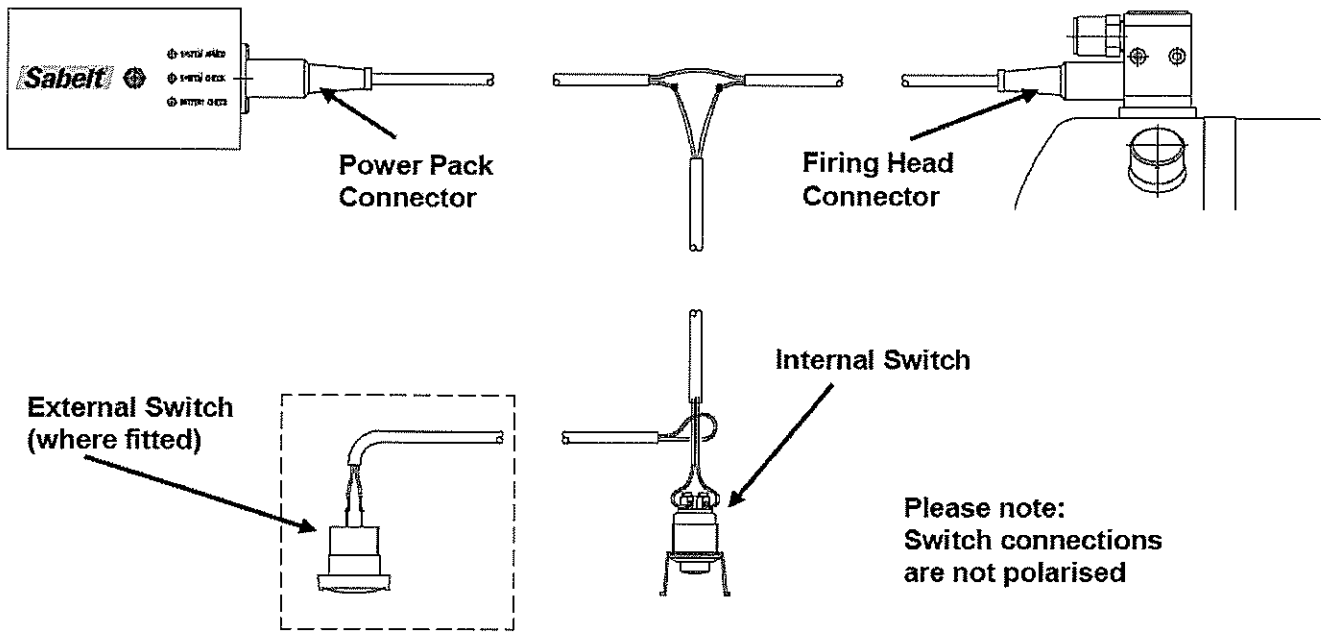

## Dual Chamber Systems

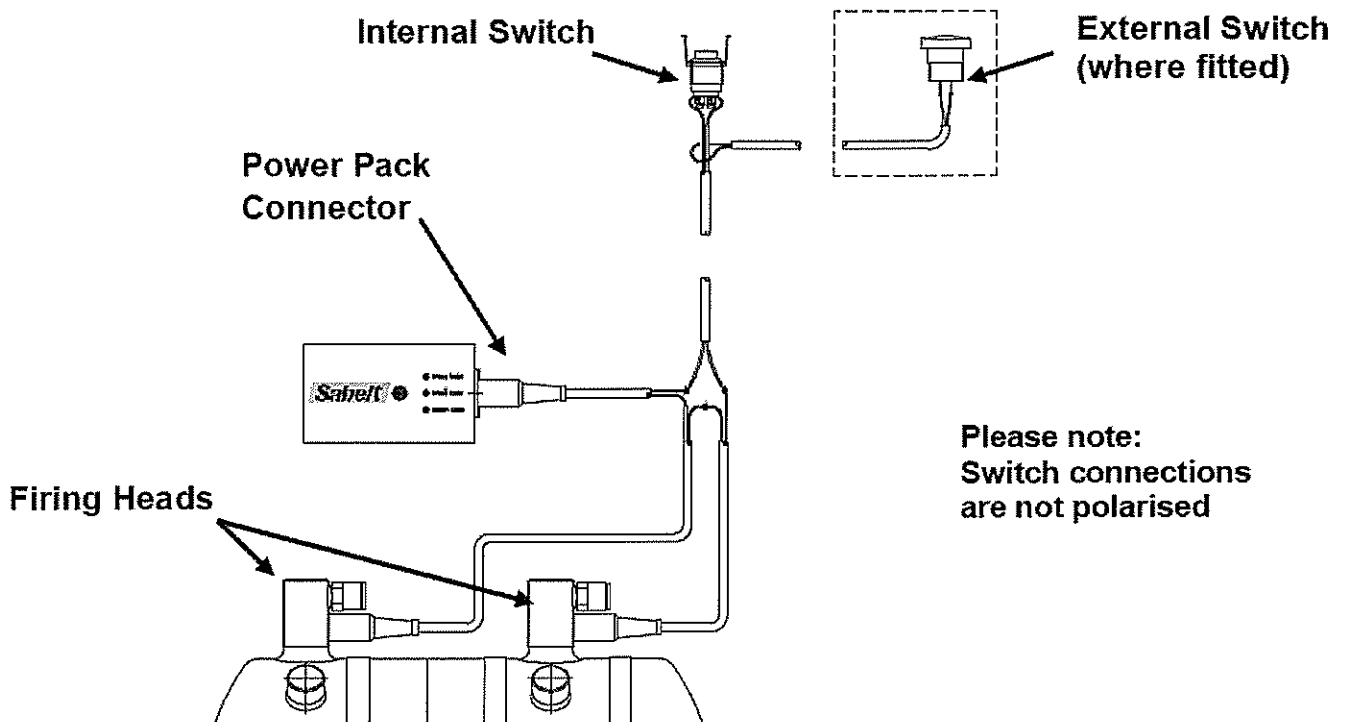

## Nozzles

It is important that the correct nozzles supplied with the system are used. The nozzles will produce an atomised foam spray. This foam spray with its controlled particle size has an excellent fire knock down and fire-out capability. It covers the area being protected with a milky foam substance which has a cooling effect and also controls re-ignition. At the end of the discharge as pressure drops the solution will thicken to a stiffer consistency. The nozzles produce a 90° full cone spray pattern with an effective discharge range of 1 metre. This should be borne in mind when locating the nozzles.

Sabelt nozzles are designed so that they can be mounted through a bulkhead or to a specially made bracket. Nozzles should be mechanically secured in position and not simply supported by their own pipework. Plastic tie wraps are not recommended for this purpose.

### System Capacity

2.25 litre

3.12 litre

3.375 litre Flow Control

3.375 litre Dual Chamber

4.0 litre

### Engine Nozzles

1

2

2

1

2

### Cockpit Nozzles

1

1

1

1

2

## Tubing

Each extinguisher kit is supplied with a roll of semi-rigid plastic coated aluminium tube. The system has been designed and homologated to use this type and size of tube. Under no circumstances should the tube be changed to another type. Additional tubing and all other parts can be obtained from Sabelt or our agents.

## Tube Connections

To enable a simple installation the extinguisher and nozzles use self-sealing push-in fittings for the tube. These fittings are supplied in appropriate sizes to match the tube diameter. To attach tube to fitting ensure that the tube end is cut at 90° and that the outside diameter has retained its circular shape. Insert the tube into the fitting pushing firmly until a positive click is felt. You should be unable to pull the tubing out of the fitting. To remove the tubing, push the tube into the fitting and pull the black collar on the fitting in the same direction. Once this is done, pull the tube from the fitting.

Correct orientation of the T piece fitting (where supplied) is critical to the performance of your system. An example is shown here with the feed to the centre leg, and the outlet legs supplying the nozzles.

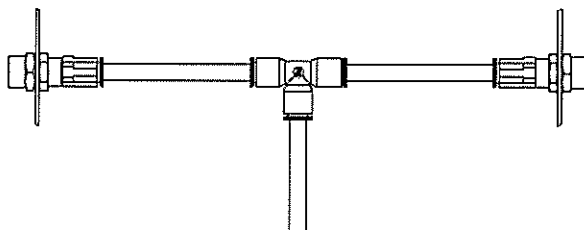

## Location of Cockpit Nozzles - Single Occupant Closed Cars

One nozzle should be mounted in the cockpit area. We recommend that this should be mounted under the dashboard and pointed to spray down into the footwell. See figure below.

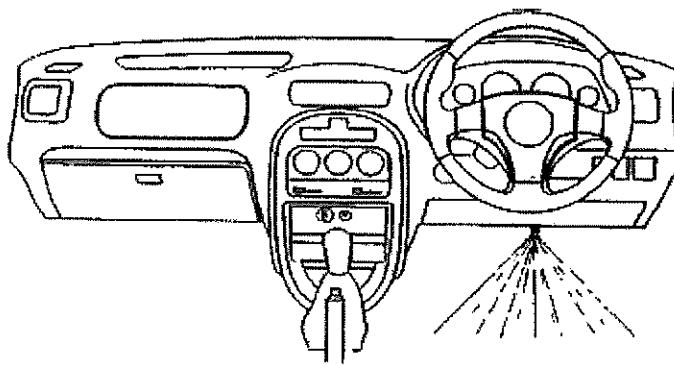



### Location of Cockpit Nozzles - Two Occupants Closed Cars

Two nozzles should be mounted in the cockpit area. We recommend that these should be mounted under the dashboard and pointed to spray down into each footwell. See figure below.

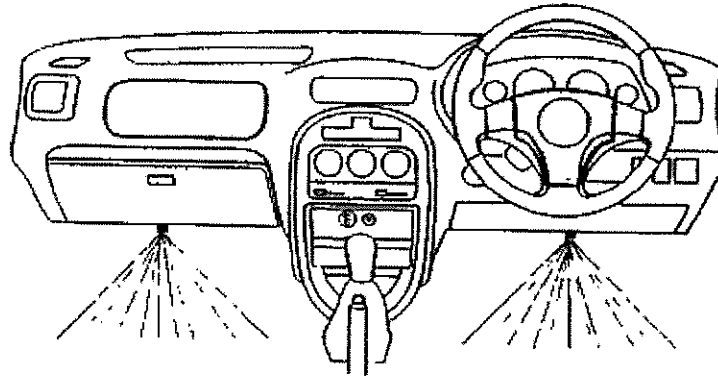

### Location of Cockpit Nozzles - Open Cars

One nozzle should be mounted in the cockpit area. We recommend that this should be mounted so that the discharge spray is aimed at the driver's midriff, in the normally seated position. Special care must be taken to ensure that the nozzle does not spray into the driver's face. See figure below.

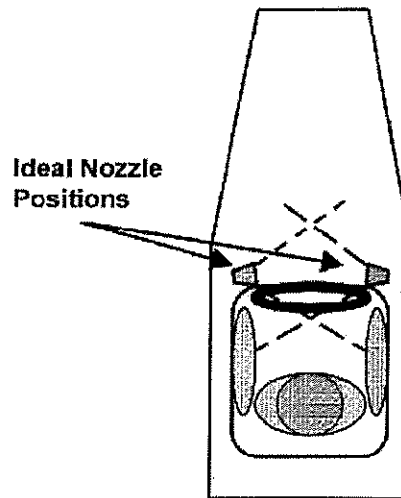

### Location of Engine Nozzles - Closed & Open Cars

The nozzle or nozzles (according to kit type) should be mounted so that as much as possible of the engine compartment will be covered by the discharge. Particular attention should be paid to the fuel and oil systems as these are the most likely sources of fire. See figure below.

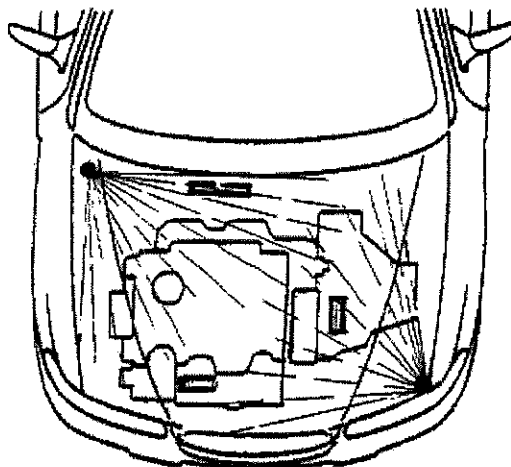

# Installation Kit Contents

## **LL102-400-001/002 - 4.0 litre Fire Marshal**

<b>Qty</b>	<b>Part Number</b>	<b>Description</b>
1		Cylinder complete with operating head, bracket & straps
1	935-100-001	6ft Pull Cable, T handle, with nipple
1	935-100-002	12ft Pull Cable, T handle, with nipple
4	955-200-004	SabLife FIA Nozzle
3	952-410-001	10mm Equal T connector
5m	951-101-010	10mm Semi-rigid tube
1	990-100-001	Decal pack

## **LL102-400-003 - 4.0 litre Electric**

1		Cylinder complete with operating head, bracket & straps
1	941-000-001	Power pack
1	942-100-001	Cockpit switch c/w Plastic Bezel
1	942-100-002	External Waterproof Switch
2	943-101-001	Plug & lead assembly, Standard
4	955-200-004	SabLife Nozzle
3	952-410-001	10mm Equal T connector
1	952-410-002	Bulkhead fitting
5m	951-101-010	10mm Semi-rigid tube
1	951-200-003	Pipe clip, pack
1	990-100-001	Decal pack

## **LL101-337-001 3.375 litre Fire Marshal Flow Control - Mechanical**

1		Cylinder complete with operating head, bracket & straps
1	935-100-001	6ft Pull Cable, T handle, with nipple
1	935-100-002	12ft Pull Cable, T handle, with nipple
3	955-200-003	SabLife MSA Nozzle
2	952-406-001	6mm Equal T connector
5m	951-101-006	6mm Semi-rigid tube
1	990-100-001	Decal pack

## **LL101-337-004 3.375 litre Electric Flow Control - Saloon/Rally Car**

1		Cylinder complete with operating head, bracket & straps
1	941-000-001	Power pack
1	942-100-001	Cockpit switch c/w Plastic Bezel
1	942-100-002	External Waterproof Switch
2	943-101-001	Plug & lead assembly, Standard
3	955-200-003	SabLife MSA Nozzle
2	952-406-001	6mm Equal T connector
1	952-406-002	Bulkhead fitting
5m	951-101-006	6mm Semi-rigid tube
1	951-200-004	Pipe clip, pack
1	990-100-001	Decal pack

## **LL101-337-005 3.375 litre Electric Flow Control - Formula Car**

1		Cylinder complete with operating head, bracket & straps
1	941-000-001	Power pack
1	942-100-001	Cockpit switch c/w Plastic Bezel
2	943-101-001	Plug & lead assembly, Standard
3	955-200-003	SabLife MSA Nozzle
2	952-406-001	6mm Equal T connector
5m	951-101-006	6mm Semi-rigid tube
1	951-200-004	Pipe clip, pack
1	990-100-001	Decal pack

## TECHNICAL SPECIFICATION OF SabLife

Product:	Fire extinguishing agent.
Usage:	Motor sports cars including saloons, single seaters and all other categories.
Contents:	Foam solutions, 10% concentration with de-ionised water.
Discharge areas:	Engine and drivers compartments.
Discharge type:	The product is stored in a container and discharged through atomising nozzles as a very fine mist. Upon settling it turns to a milky white liquid.
Composition:	Multipurpose synthetic foam based solution based on salts of alkyl sulphates and alkyl ether sulphates, together with solvents and foam stabilisers.
Appearance:	Clear amber liquid in solution.
Specific Gravity:	Typically within range 1.016 +/- 0.01.
ODP:	Ozone Depletion Potential – None.
pH:	8.0 +/- 0.5.
Cloud point:	None.
Freezing point:	-10° C
Flashpoint:	>100° C
Suspended sediment:	Less than 0.2%
Max storage temp:	+49°C
Physiological properties:	Harmless, non-toxic liquid in solution.
Road/Sea/Air Transportation:	Pressurised with Nitrogen gas.
UN classification:	Fire Extinguisher - UN1044 Class 2.2.

# MAINTENANCE

Sabelt has taken the greatest possible care in designing and manufacturing your fire suppression system. To ensure that you get the best possible performance from your SabLife system, the following checks and maintenance procedures should be carried out before the vehicle is used.

- Regularly check the pressure gauge indication is in the green sector.
- Check the integrity of the pipework and fittings.
- Check the SabLife nozzles for obstruction and foreign bodies.
- Check the cylinder for signs of damage.

Your SabLife system should be serviced every two years. A service due date is marked on the extinguisher label. It is your responsibility to ensure that the service is carried out at the correct intervals. Servicing of the extinguisher **MUST** only be carried out by Sabelt or one of our official agents.

If your SabLife system is discharged, it must be returned to Sabelt or one of our agents for refilling.

Your SabLife system will be rejected from scrutineering if:

- The pressure gauge is indicating in the red sectors
- The tamper proof labels are not intact
- Non genuine Lifeline parts have been used
- The contents are below the specified weight
- The extinguisher label is worn or illegible
- The extinguisher is not within service date
- The system is in poor condition.



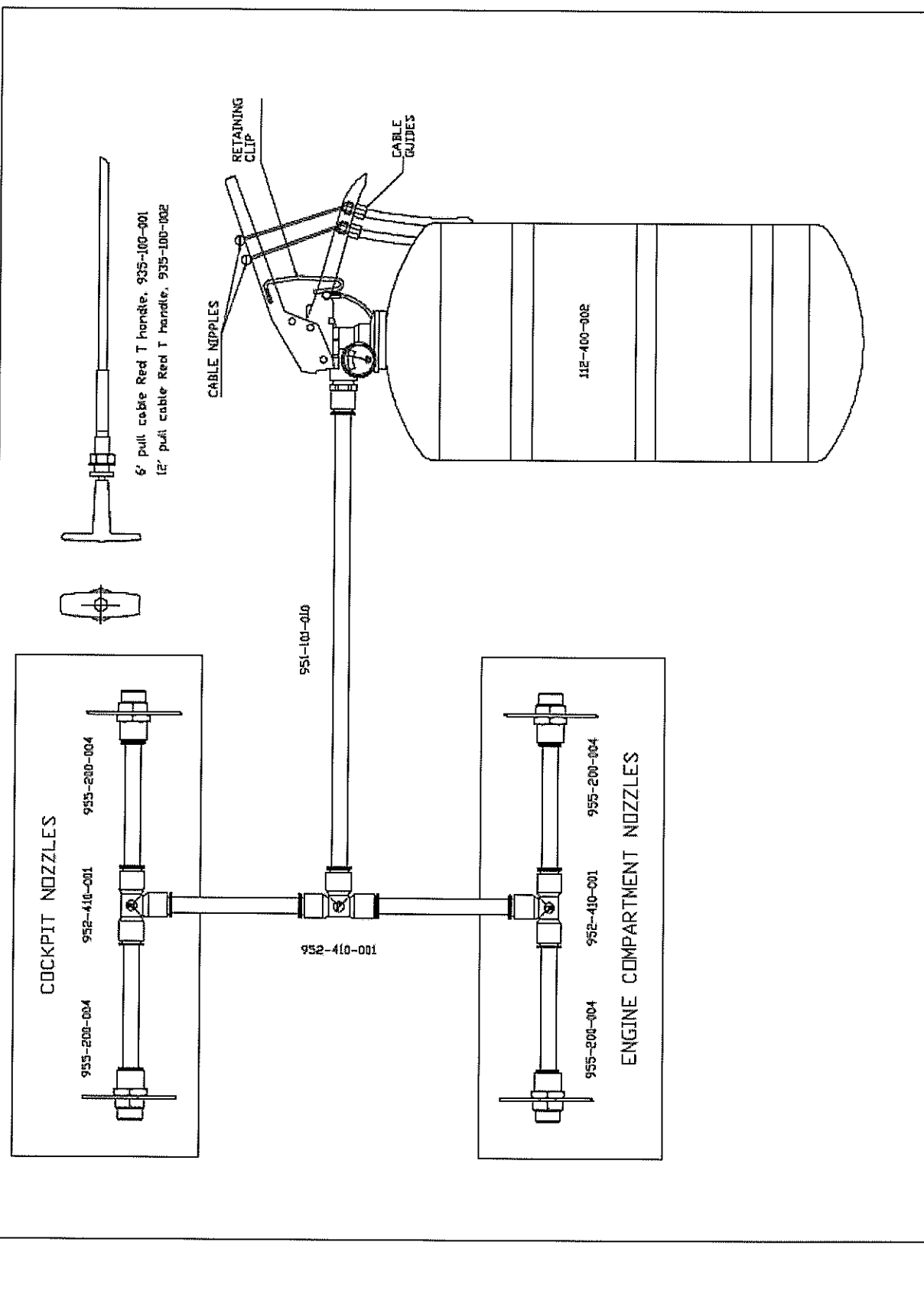

	COMPONENT / TITLE	
	102-400-002, 4.0 ltr Fire Marshal Mechanical (Alloy Cylinder)	
DATE	M.D.	BY
Nov. 07.		

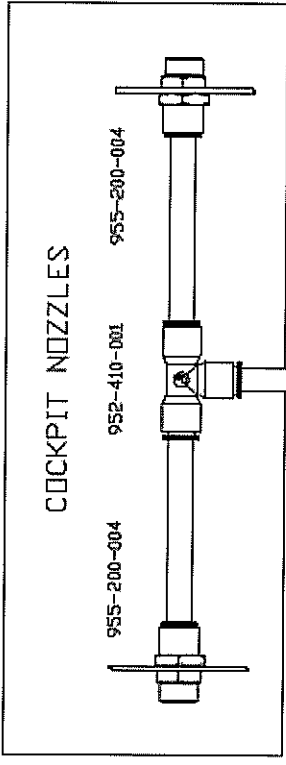

COCKPIT NOZZLES

955-200-004

952-410-001

955-200-004

952-410-001

952-410-002

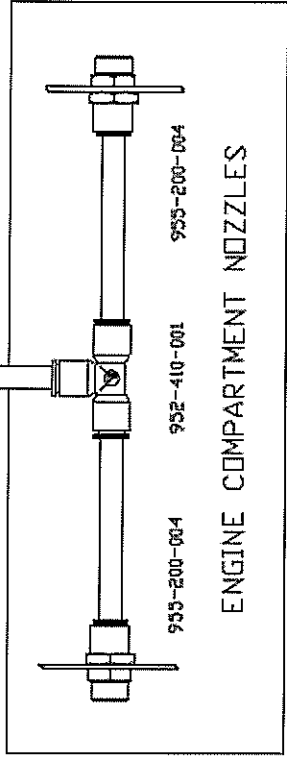

955-200-004

952-410-001

955-200-004

ENGINE COMPARTMENT NOZZLES

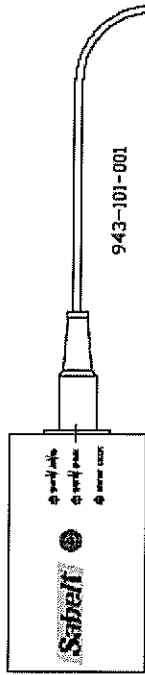

941-000-001

943-101-001

942-100-001

942-100-002

951-101-010

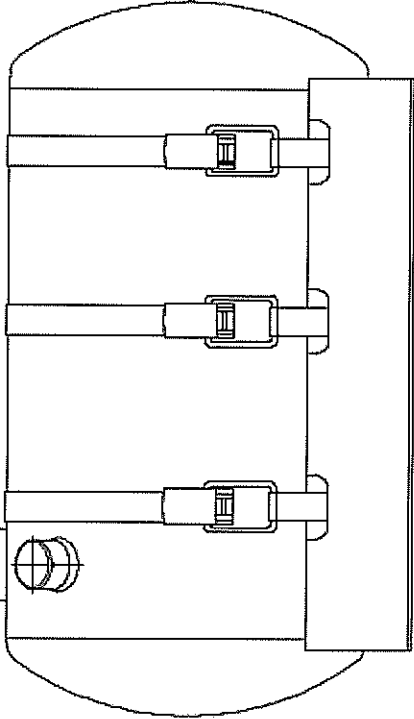

112-400-004

**Sabell** COMPONENT / TITLE  
 112-400-003, 4 ltr Electric  
 (Alloy Cylinder)  
 M.D.  
 Dec. 07.

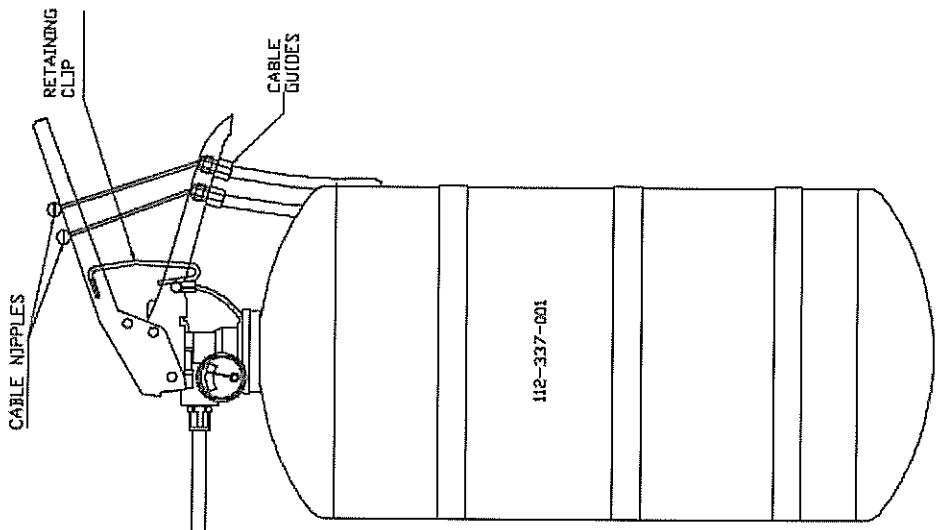
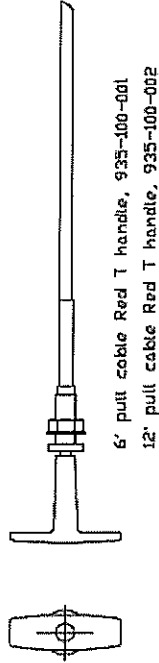
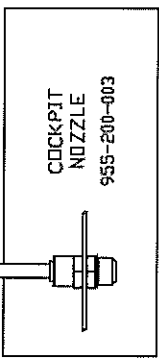
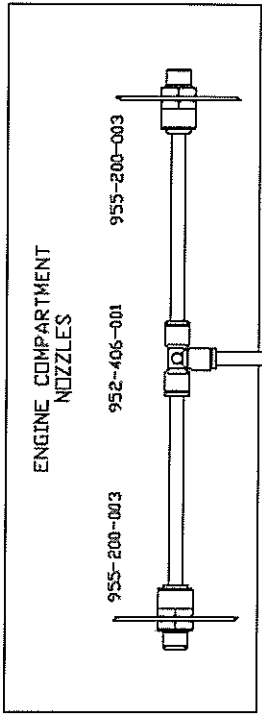

951-101-006

952-406-001

REV. M.D.  
08  
Nov. 07.

COMPONENT / TITLE  
101-337-001, 3.375 ltr. Fire Marshal Flow  
Control Mechanical (Alloy Cylinder)





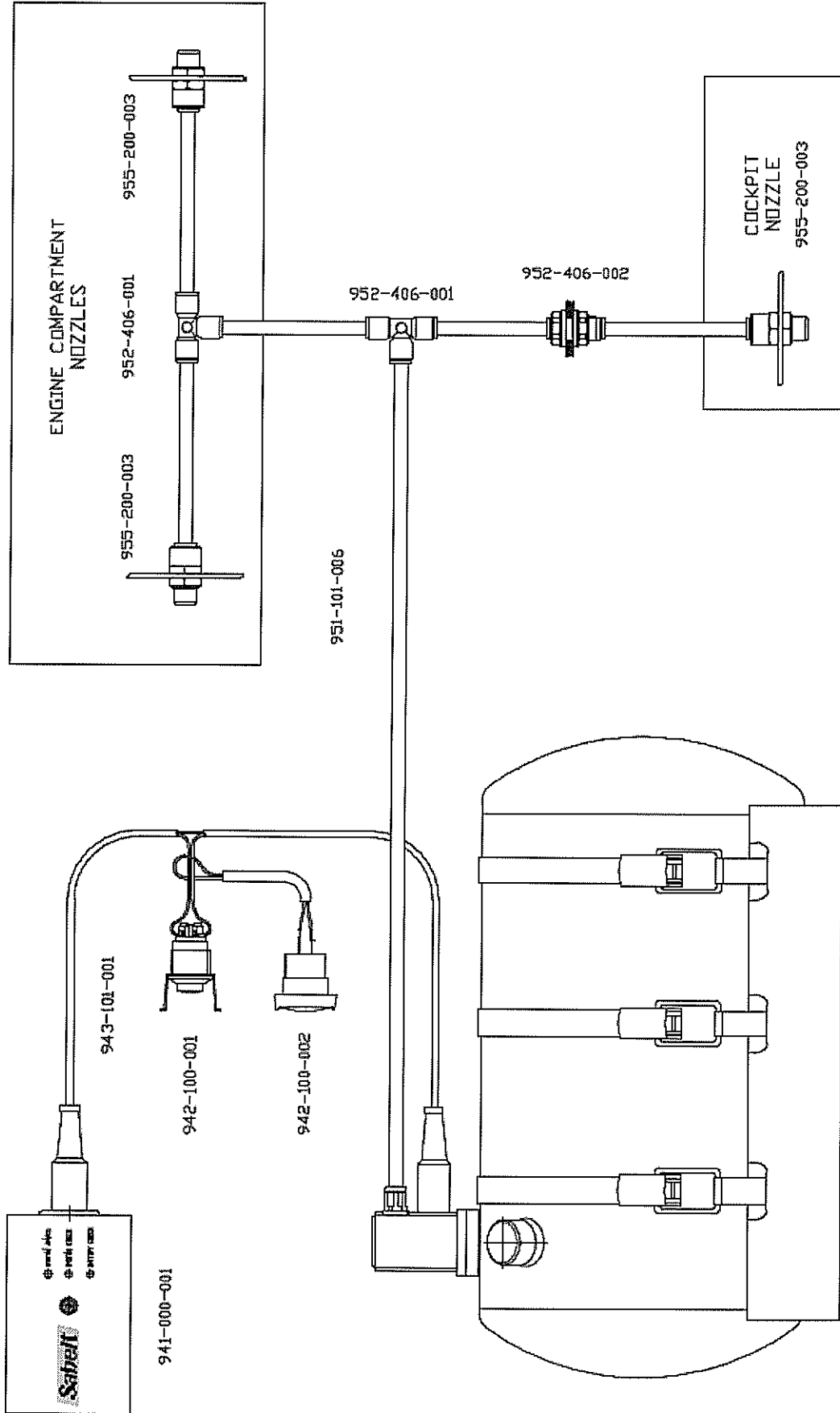

112-337-004

941-000-001

943-101-001

942-100-001

942-100-002

951-101-006

952-406-001

952-406-002

955-200-003

952-406-001

955-200-003

COCKPIT  
NOZZLE  
955-200-003

ENGINE COMPARTMENT  
NOZZLES

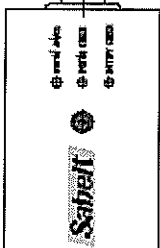

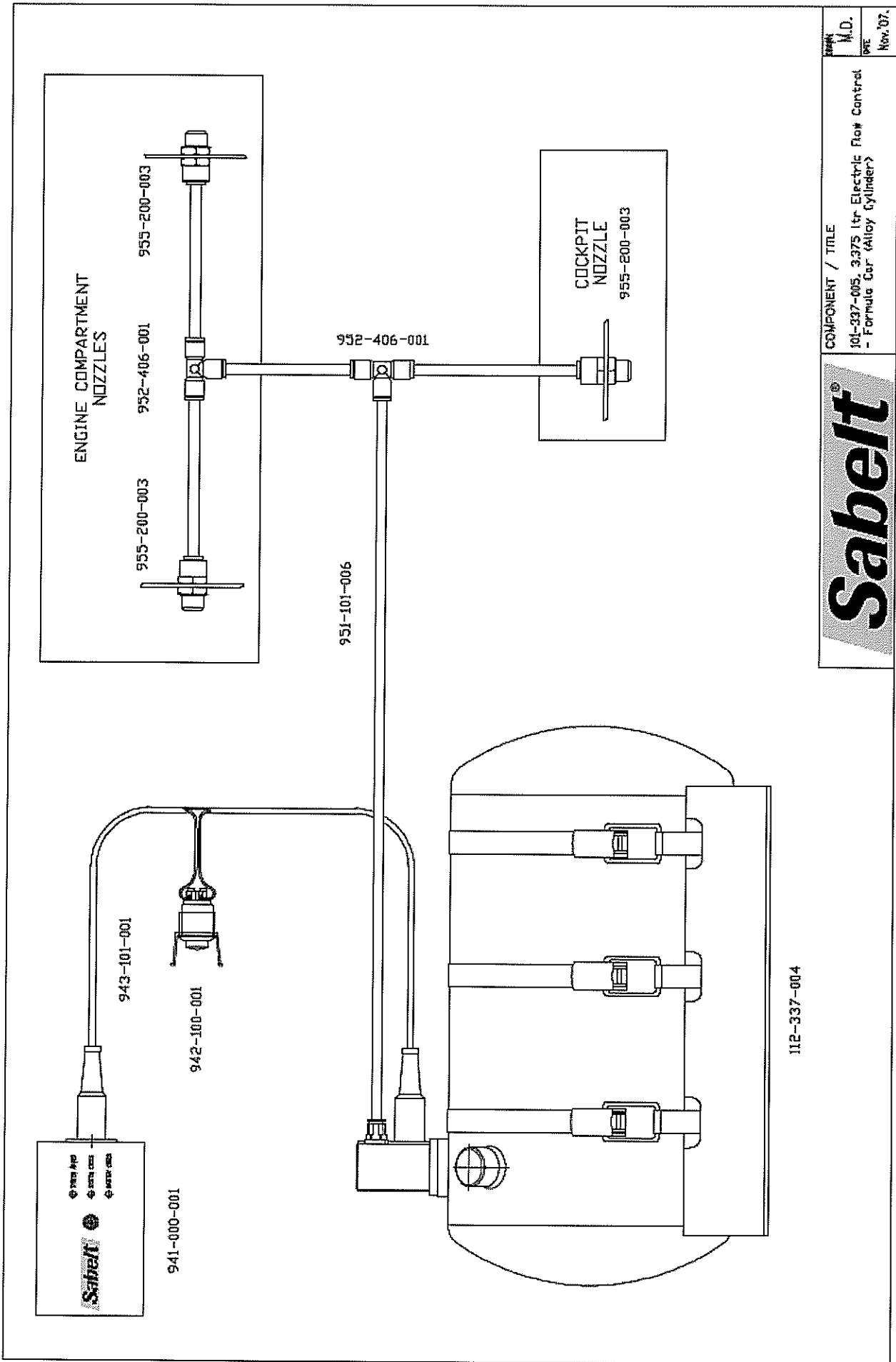

DRAWN M.D.  
 101-337-005, 3.375 ltr Electric Flow Control  
 - Formula Car (Alloy Cylinder)  
 PWE Nov. '07.

COMPONENT / TITLE  
**Sabert®**

**Sabelt<sup>®</sup>**

**Sabelt S.p.A.**

Via Guido Rossa, 10  
Moncalieri (TO) ITALY

Tel: +39 (0) 11 6477899 Fax: +39 (0) 11 6477999

Website: [www.sabelt.com](http://www.sabelt.com)

Email: [info@sabelt.com](mailto:info@sabelt.com)