

To: Teams Manufacturers

Category: LM P1 LM P2 LM GTE Pro LM GTE Am

Decision N°: 15-D0021-All categories

Date: 20/05/2015

Re: Refuelling Equipment during 24 HEURES DU MANS Test Day and Event

Mission concerned

- 2015 FIA World Endurance Championship Sporting Regulations
- 2015 Technical Regulations for Prototypes LMP1
- 2015 Technical Regulations for Prototypes LMP2
- 2015 Technical Regulations for Le Mans Grand Touring Cars - LM GTE Pro & LM GTE Am
- Internal Regulations of the FIA Endurance Commission

Decision

We remind all participants at LE MANS (Test Day and race event) that we request the "Refuelling Technical Passport":

- In electronic format (to: t.bouvet@lemans.org, jm.pialot@lemans.org, dchevrier@fia.com);
- In paper, **signed**, to be given during refueling inspection.

For all cars, the breathing fuel line should be connected as per the following drawing:

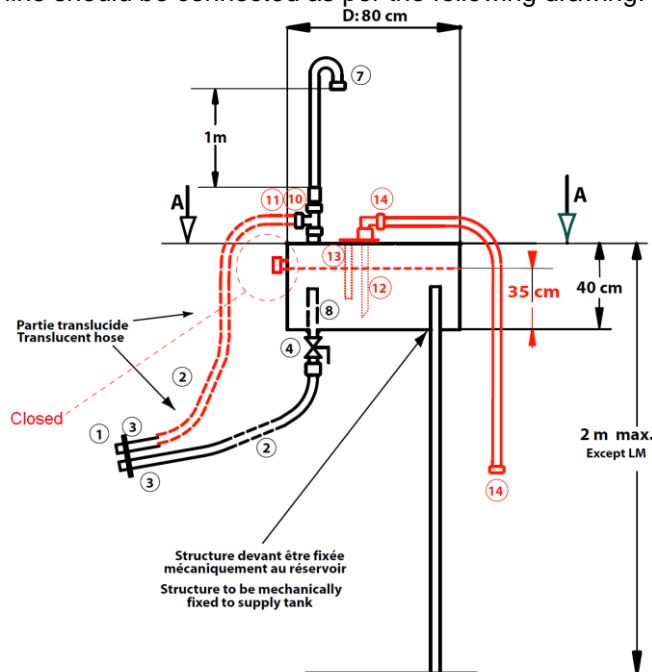

For LMP1-H only, FIA/ACO sealed 'Camlock' will be given during the scrutineering of the Test Day (2 per car). They will have the exact same measurements as the one used during the equivalence refueling test done this year. It will be mandatory to use them after the 'dead-man valve'.
 It will be required to fit a 50mm long transparent tube plugged in place of the WEC breathing connector (side of tank) in order to check that the maximum fuel level is not over 350mm from bottom of tank.
 This tube will be closed with a plug on its end.
 This tube should be visible at all time during the event and random checks will be done.

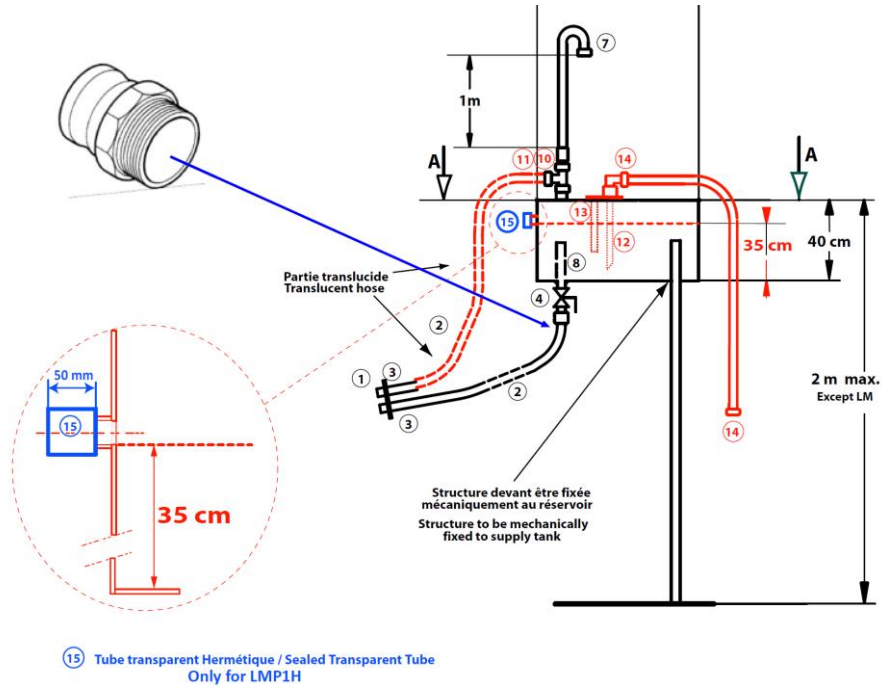

Period of validity/application of the decision

This decision comes into effect:

- with immediate application
- from:
- from the following event : **LE MANS (TEST DAY + RACE WEEK)**

And is applicable:

- until further notice
- for the above-mentioned event(s) only

Committee Members

Denis CHEVRIER

Vincent BEAUMESNIL

Any decision taken by the Endurance Committee is not subject to appeal, in accordance with Article 88 B of the WEC Sporting Regulations.

This decision is available on the following websites:

- www.fia.com
- <http://sport.lemans.org/login.php>