

2021 FORMULA 1 TECHNICAL REGULATIONS

PUBLISHED ON 5 MARCH 2021

ISSUE 9

Convention:

Black text: based on 2020 Technical Regulations – Issue 5 (19/06/2020)

Pink text: changes for 2021 approved by the WMSC on 19/06/2020, 04/09/2020, 09/10/2020, 30/10/2020, 16/12/2020, 19/02/2021 and 05/03/2021

CONTENTS:

	Pages
ARTICLE 1: DEFINITIONS	8
1.1 Formula One Car	
1.2 Automobile	
1.3 Land Vehicle	
1.4 Bodywork	
1.5 Wheel	
1.6 Complete wheel	
1.7 Automobile Make	
1.8 Event	
1.9 Weight	
1.10 Cubic capacity	
1.11 Pressure charging	
1.12 Cockpit	
1.13 Sprung suspension	
1.14 Survival cell	
1.15 Camera	
1.16 Camera housing	
1.17 Cockpit padding	
1.18 Brake caliper	
1.19 Electronically controlled	
1.20 Open and closed sections	
1.21 Power train	
1.22 Power unit	
1.23 Engine	
1.24 Energy Recovery System (ERS)	
1.25 Motor Generator Unit - Kinetic (MGU-K)	
1.26 Motor Generator Unit - Heat (MGU-H)	

- 1.27 Energy Store (ES)
- 1.28 Compressor inlet
- 1.29 Compressor outlet
- 1.30 Combustion chamber
- 1.31 Fuel injector
- 1.32 Auxiliary Oil Tank (AOT)
- 1.33 Engine exhaust system
- 1.34 Turbocharger (TC)
- 1.35 In-cylinder pressure sensor
- 1.36 High pressure Fuel pump
- 1.37 Fuel Flow meter
- 1.38 Ignition Coil
- 1.39 Ancillaries
- 1.40 Engine Plenum
- 1.41 ES cells
- 1.42 DC-DC Converter
- 1.43 Power Unit Control Electronics (PU-CE)
- 1.44 Valve Stem

ARTICLE 2: GENERAL PRINCIPLES 13

- 2.1 Role of the FIA
- 2.2 Applicable regulations and amendments to the regulations
- 2.3 Dangerous construction
- 2.4 Compliance with the regulations
- 2.5 New systems or technologies
- 2.6 Measurements
- 2.7 Duty of competitor

ARTICLE 3: BODYWORK AND DIMENSIONS 15

- 3.1 Definitions
- 3.2 Overall dimensions
- 3.3 Front wing
- 3.4 Front bodywork
- 3.5 Rear bodywork
- 3.6 Rear wing and rear impact structure
- 3.7 Floor and diffuser
- 3.8 Aerodynamic influence
- 3.9 Bodywork flexibility
- 3.10 Bodywork construction
- 3.11 Datum Points

ARTICLE 4:	WEIGHT	41
4.1	Minimum weight	
4.2	Weight distribution	
4.3	Weight of tyres	
4.4	Ballast	
4.5	Adding during the race	
4.6	Weight of the driver	
ARTICLE 5:	POWER UNIT	42
5.1	Engine specification	
5.2	Other means of propulsion and energy recovery	
5.3	Power unit dimensions	
5.4	Weight and centre of gravity	
5.5	Power unit torque demand	
5.6	Power unit control	
5.7	Engine high rev limits	
5.8	Exhaust systems	
5.9	Variable geometry systems	
5.10	Fuel systems	
5.11	Ignition systems	
5.12	Energy Recovery System (ERS)	
5.13	Engine ancillaries	
5.14	Engine intake air	
5.15	Materials and construction - Definitions	
5.16	Materials and construction – General	
5.17	Materials and construction – Components	
5.18	Materials and construction – Pressure charging and exhaust systems	
5.19	Materials and construction – Energy recovery, storage systems and electronic systems	
5.20	Starting the engine	
5.21	Stall prevention systems	
5.22	Replacing power unit parts	
ARTICLE 6:	FUEL SYSTEM	52
6.1	Fuel tanks	
6.2	Fittings and piping	
6.3	Crushable structure	
6.4	Fuel tank fillers	
6.5	Refuelling	
6.6	Fuel draining and sampling	

ARTICLE 7:	OIL AND COOLANT SYSTEMS AND CHARGE AIR COOLING	54
7.1	Location of oil tanks	
7.2	Longitudinal location of oil system	
7.3	Transversal location of oil system	
7.4	Coolant header tank	
7.5	Cooling systems	
7.6	Oil and coolant lines	
7.7	Main oil tank level measurement	
7.8	Oil injection	
ARTICLE 8:	ELECTRICAL SYSTEMS	55
8.1	Software and electronics inspection	
8.2	Control electronics	
8.3	Start systems	
8.4	Data acquisition	
8.5	Telemetry	
8.6	Driver controls and displays	
8.7	Driver radio	
8.8	Accident data recorders (ADR) and high speed accident cameras	
8.9	Track signal information display	
8.10	Medical warning system	
8.11	Installation of electrical systems or components	
ARTICLE 9:	TRANSMISSION SYSTEM	60
9.1	Transmission types	
9.2	Clutch control	
9.3	Traction control	
9.4	Clutch disengagement	
9.5	Gearboxes	
9.6	Gear ratios	
9.7	Reverse gear	
9.8	Gear changing	
9.9	Torque transfer systems	
ARTICLE 10:	SUSPENSION AND STEERING SYSTEMS	64
10.1	Sprung suspension	
10.2	Suspension geometry	
10.3	Suspension members	
10.4	Steering	
10.5	Suspension uprights	

ARTICLE 11: BRAKE SYSTEM	67
11.1 Brake circuits and pressure distribution	
11.2 Brake calipers	
11.3 Brake discs and pads	
11.4 Front air ducts	
11.5 Rear air ducts	
11.6 Common rules for front and rear air ducts	
11.7 Brake pressure modulation	
11.8 Liquid cooling	
11.9 Rear brake control system	
ARTICLE 12: WHEELS AND TYRES	70
12.1 Location	
12.2 Number of wheels	
12.3 Wheel material	
12.4 Wheel dimensions	
12.5 Supply of tyres	
12.6 Specification of tyres	
12.7 Treatment of tyres	
12.8 Wheel assembly	
ARTICLE 13: COCKPIT	72
13.1 Cockpit opening	
13.2 Steering wheel	
13.3 Internal cross section	
13.4 Position of the driver's feet	
ARTICLE 14: SAFETY EQUIPMENT	73
14.1 Fire extinguishers	
14.2 Master switch	
14.3 Rear view mirrors	
14.4 Safety belts	
14.5 Rear lights	
14.6 Cockpit padding	
14.7 Wheel retention	
14.8 Seat fixing and removal	
14.9 Head and neck supports	
ARTICLE 15: CAR CONSTRUCTION	78
15.1 Permitted materials	
15.2 Roll structures	

15.3	Structure behind the driver	
15.4	Survival cell specifications	
15.5	Survival cell safety requirements	
ARTICLE 16:	IMPACT TESTING	86
16.1	Conditions applicable to all impact tests	
16.2	Frontal test 1	
16.3	Frontal test 2	
16.4	Rear test	
16.5	Steering column test	
ARTICLE 17:	ROLL STRUCTURE TESTING	89
17.1	Principal roll structure test	
17.2	Second roll structure attachments tests	
ARTICLE 18:	STATIC LOAD TESTING	90
18.1	Conditions applicable to all static load tests	
18.2	Survival cell side tests	
18.3	Survival cell floor test	
18.4	Cockpit floor test	
18.5	Cockpit rim tests	
18.6	Nose push off test	
18.7	Side intrusion test	
18.8	Rear impact structure push off test	
18.9	Side impact structure push off tests	
18.10	Side impact structure squeeze tests	
ARTICLE 19:	FUEL	94
19.1	Purpose of Article 19	
19.2	Definitions	
19.3	Properties	
19.4	Composition of the fuel	
19.5	Air	
19.6	Safety	
19.7	Fuel approval	
19.8	Sampling and testing at an Event	
ARTICLE 20:	ENGINE OIL	97
20.1	Purpose of Article 20	
20.2	Definitions	
20.3	Properties	

20.4	Composition of the engine oil	
20.5	Safety	
20.6	Engine oil approval	
20.7	Sampling and testing at an Event	
ARTICLE 21:	TELEVISION CAMERAS AND TIMING TRANSPONDERS	100
21.1	Presence of cameras and camera housings	
21.2	Location and fitting of camera equipment	
21.3	Transponders	
21.4	Installation	
ARTICLE 22:	COMPONENTS' CLASSIFICATION AND HOMOLOGATION	102
22.1	Definitions	
22.2	General Principles	
22.3	Listed Team Components (LTC)	
22.4	Standard Supply Components (SSC)	
22.5	Transferable Components (TRC) and Free Supply Components (FSC)	
22.6	Open Source Components (OSC) for 2022	
22.7	Homologated Components (HC) for 2021	
22.8	Classification, homologation and perimeter of each group	
ARTICLE 23:	FINAL TEXT	112
APPENDIX 1:	DRAWINGS	113
APPENDIX 2:	POWER UNIT SYSTEMS, FUNCTIONS AND COMPONENTS	117
APPENDIX 3:	POWER UNIT ENERGY FLOW	121
APPENDIX 4:	COMPONENTS' CLASSIFICATION, HOMOLOGATION STATUS AND PERIMETER	122
APPENDIX 5:	TERMS AND CONDITIONS FOR THE USE OF THE FIA SERVER	137

ARTICLE 1: DEFINITIONS

1.1 Formula One Car

An automobile designed solely for speed races on circuits or closed courses.

1.2 Automobile

A land vehicle running on at least four non-aligned complete wheels, of which at least two are used for steering and at least two for propulsion.

1.3 Land vehicle

A locomotive device propelled by its own means, moving by constantly taking real support on the earth's surface, of which the propulsion and steering are under the control of a driver aboard the vehicle.

1.4 Bodywork

All entirely sprung parts of the car in contact with the external air stream, except cameras, camera housings, rear view mirrors as defined in Article 14.3, ERS status lights, the secondary roll structure and associated fixings and fairings and the parts definitely associated with the mechanical functioning of the engine, transmission and running gear. Airboxes, radiators and engine exhausts are considered to be part of the bodywork.

1.5 Wheel

Flange and rim.

1.6 Complete wheel

Wheel and inflated tyre. The complete wheel is considered part of the suspension system.

1.7 Automobile Make

In the case of Formula racing cars, an automobile make is a complete car. When the car manufacturer fits an engine which it does not manufacture, the car shall be considered a hybrid and the name of the engine manufacturer shall be associated with that of the car manufacturer. The name of the car manufacturer must always precede that of the engine manufacturer. Should a hybrid car win a Championship Title, Cup or Trophy, this will be awarded to the manufacturer of the car.

1.8 Event

Any event entered into the FIA F1 Championship Calendar for any year commencing 24 hours before P1 is scheduled to take place and including all practice and the race itself and ending at the later of the time for the lodging of a protest under the terms of the Sporting Code and the time when a technical or sporting verification has been carried out under the terms of that Code, whichever is the later.

1.9 Weight

Is the weight of the car with the driver, wearing his complete racing apparel, at all times during the Event.

1.10 Engine cubic capacity

The volume swept in the cylinders of the engine by the movement of the pistons. This volume shall be expressed in cubic centimetres. In calculating engine cubic capacity, the number Pi shall be 3.1416.

1.11 Pressure charging

Increasing the weight of the charge of the fuel/air mixture in the combustion chamber (over the weight induced by normal atmospheric pressure, ram effect and dynamic effects in the intake and/or exhaust system) by any means whatsoever. The injection of fuel under pressure is not considered to be pressure charging.

1.12 Cockpit

The volume which accommodates the driver.

1.13 Sprung suspension

The means whereby all complete wheels are suspended from the unit comprising the survival cell/power unit/gearbox by a spring medium.

1.14 Survival cell

The continuous closed structure containing the fuel tank, the cockpit and the parts of the ES listed in Article 5.12.7.

1.15 Camera

Television cameras the dimensions of which are defined in Drawing 6.

1.16 Camera housing

A device which is identical in shape and weight to a camera and which is supplied by the relevant competitor for fitting to his car in lieu of a camera.

1.17 Cockpit padding

Non-structural parts placed within the cockpit for the sole purpose of improving driver comfort and safety. All such material must be quickly removable without the use of tools.

1.18 Brake caliper

All parts of the braking system outside the survival cell, other than brake discs, brake pads, caliper pistons, components directly associated with the system referred to in Article 11.9, brake hoses and fittings, which are stressed when subjected to the braking pressure. Bolts or studs which are used for attachment are not considered to be part of the braking system.

1.19 Electronically controlled

Any command system or process that utilises semi-conductor or thermionic technology.

1.20 Open and closed sections

A section will be considered closed if it is fully complete within the dimensioned boundary to which it is referenced, if it is not it will be considered open.

1.21 Power train

The power unit and associated torque transmission systems, up to but not including the drive shafts.

1.22 Power unit

The internal combustion engine, complete with its ancillaries, any energy recovery system and all actuation systems and **PU-Control Electronics** necessary to make them function at all times.

1.23 Engine

The internal combustion engine including ancillaries and actuator systems necessary for its proper function.

1.24 Energy Recovery System (ERS)

A system that is designed to recover energy from the car, store that energy and make it available to propel the car and, optionally, to drive any ancillaries and actuation systems necessary for its proper function.

1.25 Motor Generator Unit - Kinetic (MGU-K)

The Kinetic Motor Generator Unit is the electrical machine mechanically linked to the drive train as part of the ERS.

1.26 Motor Generator Unit - Heat (MGU-H)

The Heat Motor Generator Unit is the electrical machine linked to the exhaust turbine of a pressure charging system as part of the ERS.

1.27 Energy Store (ES)

The part of ERS that stores energy, including its safety control electronics and a minimal housing.

1.28 Compressor inlet

A component containing a duct of closed cross section through which all air destined for combustion enters any compressor; the duct must extend upstream of any part of any variable geometry device permitted by Article 5.9.

1.29 Compressor outlet

One or more components each of them containing a duct of closed cross section through which all air destined for combustion exits a compressor.

1.30 Combustion chamber

An enclosed space in the engine cylinder controlled by the opening and closing of the poppet valves in which combustion takes place.

1.31 Fuel injector

Any device or component that delivers fuel into an oxidiser.

1.32 Auxiliary Oil Tank (AOT)

An Auxiliary Oil Tank (AOT) is a singular vessel connected to the engine whose sole function is to hold engine oil for the replenishment of the engine lubrication system.

1.33 Engine exhaust system

Assembly of parts conveying the engine exhaust gases from the **cylinder head** up to but not including the turbine and/or wastegate. It does not include the turbine or wastegate exit tail-pipe(s). A set comprises left and right assemblies.

1.34 Turbocharger (TC)

The assembly of a compressor used for pressure charging of the engine, a turbine connected to the engine exhaust system used to drive the compressor, the drive system between the compressor and the turbine and their respective housings and bearings.

1.35 In-cylinder pressure sensor

A sensor whose function is to measure the pressure in the combustion chamber.

1.36 High pressure Fuel pump

A mechanical device whose sole function is to pressurise the fuel to the pressure required for the high-pressure injection. It may be electronically controlled.

1.37 Fuel Flow meter

A sensor whose function is to measure the flow of the fuel passing through it.

1.38 Ignition Coil

Assembly including an induction coil that supplies the high voltage to the spark plug.

1.39 Ancillaries

A component whose function is to support the primary activities of a main system to allow it to operate.

1.40 Engine Plenum

A pressurised vessel upstream of the combustion chamber containing air destined for combustion. This vessel (or vessels) may be comprised of several components. Pipes, as generally understood, conveying air from the compressor to the engine are not part of the engine plenum.

1.41 ES cells

The elementary part of the ES that produces and stores electricity through electro-chemical reactions.

1.42 DC-DC Converter

An electronic circuit or electromechanical device, only capable of consuming energy, that converts a source of direct current (DC) from one voltage level to another for use by the electrical and electronic components of the car and power unit.

1.43 Power Unit Control Electronics (PU-CE)

Any component used to control Power Unit sub-systems and containing programmable semiconductors or high power switching devices.

It includes, but is not limited to, MGU-K control unit, MGU-H control unit, injector control unit, ignition control unit, DC-DC.

It excludes any FIA Standard ECU, FIA sensors and ES safety control electronics.

1.44 Valve Stem

The valve stem is the part of the component that slides within the valve guide during operation.

ARTICLE 2: GENERAL PRINCIPLES

2.1 Role of the FIA

The following technical regulations for Formula One cars are issued by the FIA.

2.2 Applicable regulations and amendments

The regulations applicable to the Championship are the International Sporting Code (the “Code”), the Formula One Technical Regulations (the “Technical Regulations”), the Formula One Sporting Regulations (the “Sporting Regulations”), and the Formula One Financial Regulations (the “Financial Regulations”), together referred to as the “Regulations”.

These Technical Regulations apply to the whole calendar year referred to in the title, and to the Championship taking place within that calendar year (“the Championship”). Any changes made by the FIA for safety reasons may come into effect without notice or delay.

2.3 Dangerous construction

The stewards may exclude a vehicle whose construction is deemed to be dangerous.

2.4 Compliance with the regulations

Automobiles must comply with these regulations in their entirety at all times during an Event.

Should a competitor introduce a new design or system or feel that any aspect of these regulations is unclear, clarification may be sought from the FIA Formula One Technical Department. If clarification relates to any new design or system, correspondence must include:

- a. A full description of the design or system.
- b. Drawings or schematics where appropriate.
- c. The competitor's opinion concerning the immediate implications on other parts of the car of any proposed new design.
- d. The competitor's opinion concerning any possible long term consequences or new developments which may come from using any such new designs or systems.
- e. The precise way or ways in which the competitor feels the new design or system will enhance the performance of the car.

2.5 New systems or technologies

Any new system, procedure or technology not specifically covered by these regulations, but which is deemed permissible by the FIA Formula One Technical Department, will only be admitted until the end of the Championship during which it is introduced. Following this the Formula One Commission will be asked to review the technology concerned and, if they feel it adds no value to Formula One in general, it will be specifically prohibited.

Any team whose technology is prohibited in this way will then be required to publish full technical details of the relevant system or procedure.

2.6 Measurements

All measurements must be made while the car is stationary on a flat horizontal surface.

2.7 Duty of Competitor

It is the duty of each competitor to satisfy the FIA technical delegate and the stewards that his automobile complies with these regulations in their entirety at all times during an Event.

The design of the car, its components and systems shall, with the exception of safety features, demonstrate their compliance with these regulations by means of physical inspection of hardware or materials. No mechanical design may rely upon software inspection as a means of ensuring its compliance.

Due to their nature, the compliance of electronic systems may be assessed by means of inspection of hardware, software and data.

CAD models may be requested by the FIA in order to check compliance with the Regulations. Such models should be supplied in a format and by a method specified by the FIA. In such cases, scanning technology will be used by the FIA to check that the physical car is the same as the inspected CAD models.

Each competitor must ensure that all relevant personnel (whether employee, consultant, contractor, secondee or any other type of permanent or temporary personnel) associated with its participation in the Championship are appropriately informed with respect to the ways in which their areas of responsibility may impact the competitor's compliance with the Regulations.

Each competitor must ensure that the FIA ethics and compliance hotline with respect to the Regulations is clearly communicated to all these individuals.

2.8 Precision of Numerical Values

Any numerical values specified in these Regulations as limits (maxima or minima), will be considered to be the limits regardless of the decimals quoted.

ARTICLE 3: BODYWORK AND DIMENSIONS

Infinite precision can be assumed on certain dimensions provided it is clear that such an assumption is not being made in order to circumvent or subvert the intention of the relevant regulation.

Section titles, Article titles and drawings, within this article, have no regulatory value.

3.1 Definitions

3.1.1 Wheel centre line

The centre line of any wheel shall be deemed to be half way between two straight edges, perpendicular to the surface on which the car is standing, placed against opposite sides of the complete wheel at the centre of the tyre tread.

3.1.2 Height measurements

All height measurements will be taken normal to and from the reference plane defined in Article 3.7.1.

3.1.3 Distances

All measurements relative to wheel centre lines, car centre plane and survival cell planes (referring to Drawing 5) will be taken parallel to the reference plane defined in Article 3.7.1.

3.2 Overall dimensions

3.2.1 Height

No part of the bodywork may be more than 950mm above the reference plane.

3.2.2 Width

The overall width of the car, excluding tyres, must not exceed 2000mm with the steered wheels in the straight ahead position.

Bodywork width between the front and the rear wheel centre lines must not exceed 1600mm.

3.2.3 Overhangs

No part of the car may be more than 810mm behind the rear wheel centre line or more than 1225mm in front of the front wheel centre line.

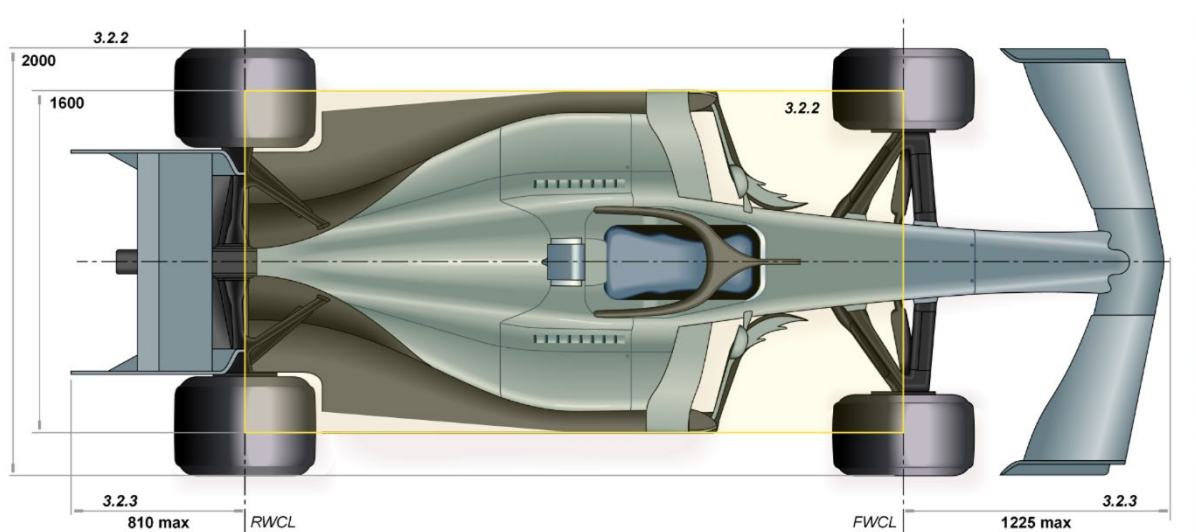

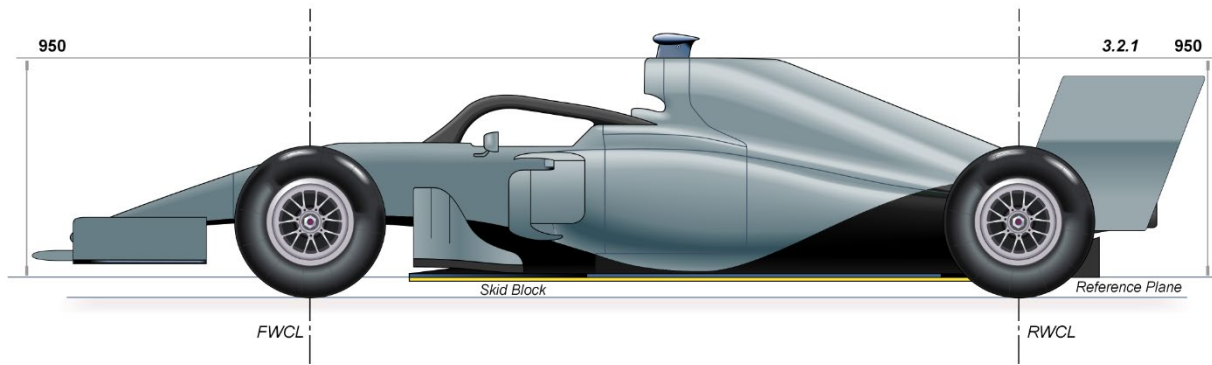

3.3 Front wing

3.3.1 Mandatory central section

Any vertical section taken parallel to the car centre plane through bodywork located more than 450mm forward of the front wheel centre line, less than 250mm from the car centre plane, and less than 125mm above the reference plane must only contain a single section, which:

- a. Conforms to the profile and incidence defined by the coordinates specified in Drawing 7 (with the exception of local changes of section where the bodywork defined in Article 3.3.2 attaches) with a manufacturing tolerance of $\pm 0.500\text{mm}$.
- b. Lower trailing edge point, as defined in Drawing 7, is 86.650mm above the reference plane with a manufacturing tolerance of $\pm 2.000\text{mm}$.
- c. Has its forward most point lying on a curve, when viewed from above, defined by:
 - i. A diagonal line from a point 1225mm forward of the front wheel centre line and on the car centre plane to a point 1025mm in front of the front wheel centre line and 1000mm from the car centre plane.
 - ii. A 500mm radius tangent to this line and perpendicular to the car centre plane at the car centre plane with its centre less than 1225mm forward of the front wheel centre line. Once the 500mm radius is defined, the diagonal line is trimmed to the intersection point with the radius, retaining the outboard segment.

with a manufacturing tolerance of 2.000mm behind this curve only.

The above tolerances are to help overcome any possible manufacturing problems, and not to permit any design which may contravene any part of these regulations.

Furthermore, bodywork in this area may not contain any closed channel the effect of which is to duct air directly or indirectly to or from the external air stream for any purpose other than data acquisition.

3.3.2 Pylons

Any horizontal section taken through bodywork located forward of a point lying 450mm forward of the front wheel centre line, less than 250mm from the car centre plane, and between 125mm and 135mm above the reference plane, may only contain two closed symmetrical sections with a maximum total area of $5,000\text{mm}^2$. The thickness of each section may not exceed 25mm when measured perpendicular to the car centre plane.

Once fully defined, the sections at 125mm above the reference plane must be projected vertically to join the profile required by Article 3.3.1. A radius no greater than 10mm may be used where these sections join.

3.3.3 Overall dimensions

All bodywork situated forward of a point lying 330mm behind the front wheel centre line, and more than 250mm from the car centre plane, must be no less than 75mm and no more than 300mm above the reference plane.

When viewed from above, this bodywork must lie within the area enclosed by the intersection of four lines:

- a. A diagonal line from a point 1225mm forward of the front wheel centre line and on the car centre plane to a point 1025mm in front of the front wheel centre line and 1000mm from the car centre plane.
- b. A longitudinal line parallel to and 1000mm from the car centre plane.
- c. A diagonal line from a point 650mm forward of the front wheel centre line and on the car centre plane to a point 450mm in front of the front wheel centre line and 1000mm from the car centre plane.
- d. A longitudinal line parallel to and 250mm from the car centre plane.

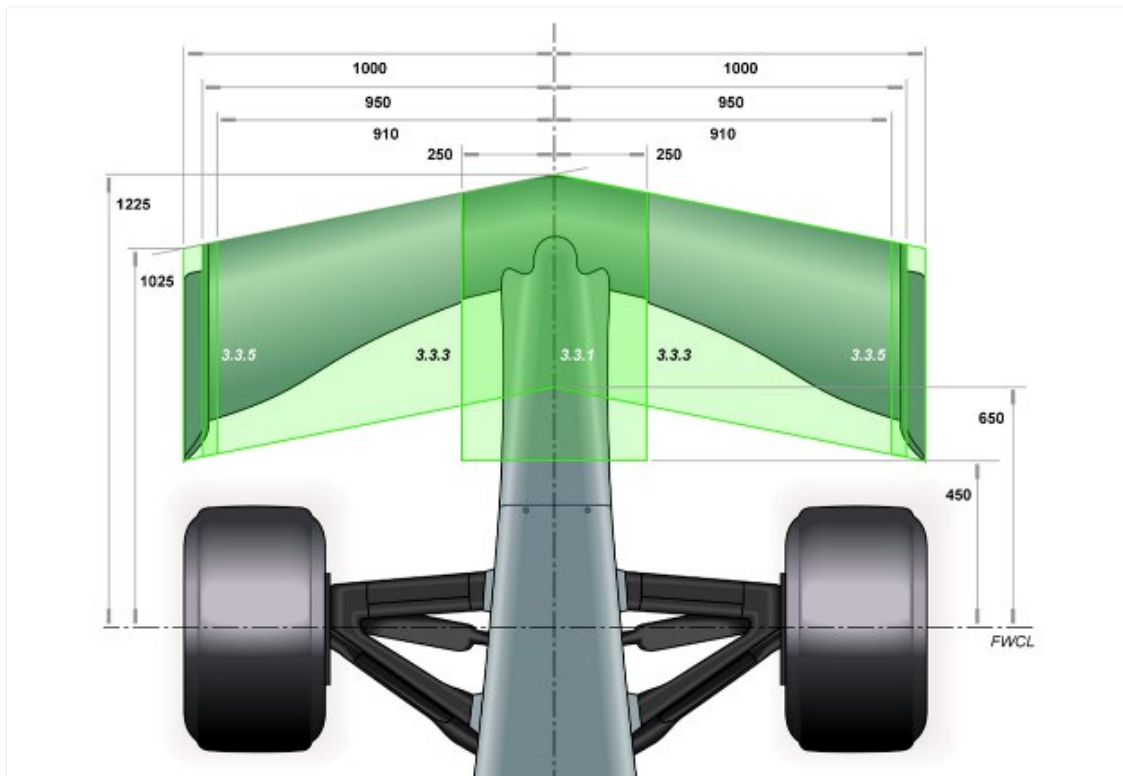
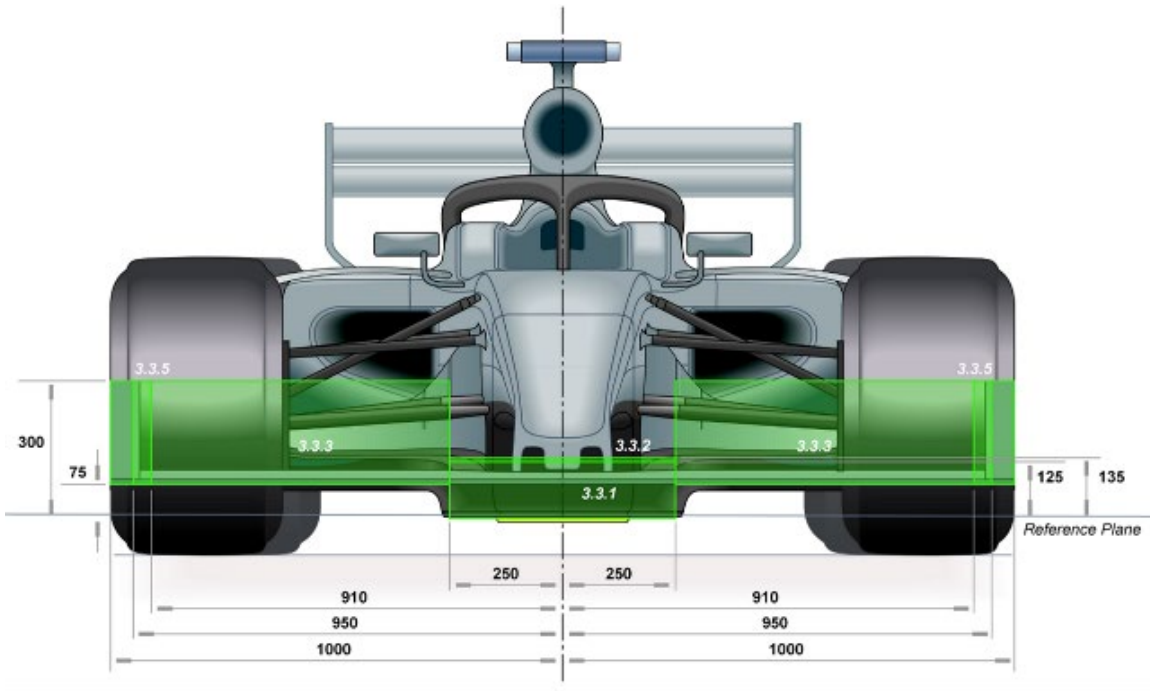

3.3.4 Definition of components

On each side of the car, the volume described in Article 3.3.3 can only contain the following components:

- a. The front wing endplate defined in Article 3.3.5.
- b. The front wing profiles defined in Article 3.3.6.
- c. A maximum of two front wing strakes as defined in Article 3.3.8.
- d. The front wing auxiliary components defined in Article 3.3.9.

3.3.5 Front wing endplate

A mathematical surface (referred to as the “virtual endplate surface”) must be constructed in order to subsequently define the endplate.

The virtual endplate surface must:

- a. Lie entirely between 910mm and 950mm from the car centre plane.
- b. Extend forwards, rearwards, upwards and downwards in such way as to intersect respectively the forward, rearward, upper and lower bounding surfaces of the volume defined in Article 3.3.3 over its entire length and height.
- c. In no place have a normal which subtends an angle greater than 15° to an axis normal to the car centre plane.
- d. Produce one single continuous curve, which is entirely visible from side view, when intersected with any lateral vertical or horizontal plane.

The front wing endplate is defined as the bodywork created by the union of two volumes.

The first such volume:

- e. Must fully enclose a minimum of 95% of the virtual endplate surface.
- f. Over its forward-most 150mm, measured in the longitudinal direction, must in no part be distant more than 10mm from the virtual endplate surface, while over the rest of its volume must in no part be more than 6mm distant from the virtual endplate surface.
- g. Is a single volume which contains no apertures and any intersection with any lateral or horizontal plane may only produce a single closed section.

The second such volume:

- h. Must have no part which is distant more than 30mm from the virtual endplate surface towards the car centre plane. Any part inboard of the virtual endplate surface must lie in its entirety between 75mm and 85mm above the reference plane.
- i. Lies in its entirety between 75mm and 110mm from the reference plane.
- j. Is a single volume which contains no apertures or slots.
- k. When viewed from below, has a boundary which does not contain any external local concave radius of curvature smaller than 200mm.

Once the two volumes have been defined, a fillet radius of up to 5mm will be permitted where they intersect. Any cross section of the unified volume with a lateral vertical plane should contain only a single closed section.

In order to prevent tyre damage to other cars, the complete endplate, with the exception of parts of the second volume inboard of the virtual endplate surface must be at least 10mm thick (being the minimum distance when measured normal to the surface in any direction) with a 5mm radius applied to all extremities.

In addition, the leading 50mm of this bodywork, with the exception of fasteners and inserts as described below, must be of a prescribed laminate, details of this laminate may be found in the Appendix to the Technical and Sporting Regulations.

Fasteners and related inserts, for the purpose of attaching the front wing endplate to the profiles must be positioned at least 30mm rearward of the leading edge of the endplate.

3.3.6 Front wing profiles

Front wing profiles are defined as bodywork that is contained in the volume which extends from 250mm to 950mm from the car centre plane, and within the volume defined in Article 3.3.3. They must meet the following criteria:

- a. Any intersection of these profiles with any longitudinal vertical plane may contain no more than five closed sections, each of which may contain no concave radius of curvature less than 50mm.
- b. For the part of the profiles outboard of a plane that lies 400mm from the car centre plane:
 - i. The rearmost point of every closed section must be visible when viewed from below.
 - ii. With the exception of the rearmost closed section, the rearmost point of every closed section must not be visible when viewed from above.
 - iii. The normal to any point of the profiles' surface must not subtend an angle greater than 15° to a vertical plane which is normal to the diagonal line described in Article 3.3.3(a).
- c. Outboard of a plane that lies 400mm from the car centre plane the minimum distance between adjacent sections at any longitudinal vertical plane must lie between 5mm and 15mm at their closest position.

Once the rearmost profile has been defined a single 'gurney' type trim tab may be fitted to its trailing edge provided no dimension in a vertical longitudinal section exceeds 10mm. This part must comply with the constraints of Article 3.3.6 (b) (iii), with the exception of its innermost and outermost 10mm (measured in a direction normal to the car centre plane) where these constraints do not apply. For clarity, gurneys that overlap with the adjustable and non-adjustable portion of the profiles (as described in Article 3.3.7) will be considered to be a single gurney, provided they satisfy all of the above criteria in the design position of the profiles.

Minimal exceptions to the above geometrical criteria can occur in areas of transition close to consecutive longitudinal vertical cross sections with a different number of individual profiles. Outboard of a longitudinal plane that lies 400mm from the car centre plane, such changes may only be achieved by the bifurcation of a single closed section into two or more closed sections, and the method of construction of this transition is detailed below.

The area of transition will be defined by two vertical planes, which are parallel to each other, up to 20mm apart, and form an angle of no more than 20° to the car centre plane. Within this area:

- d. The inboard (single) profile surface must be defined over the full span of the transition area in full compliance with Article 3.3.6.
- e. The outboard profile (two or more) surfaces must be defined over the full span of the transition area in full compliance with Article 3.3.6, lie entirely within the single profile surface, and share the same overall chord.
- f. Once the inboard and outboard profile surfaces have been defined, blending surfaces must be defined to join the profiles together. These surfaces must lie within the volume of the single, inboard profile surface, and entirely within the transition volume. Once these minimal transition surfaces have been defined, the original overlapping surfaces of the inboard and outboard profiles must be trimmed accordingly.

The construction method described above may also be used to define the transition outboard of the single section defined by Article 3.3.1 and the sections that lie outboard of it. For the avoidance of doubt, these transition surfaces must lie entirely outboard of a vertical longitudinal plane that lies 250mm from the car centre plane.

Once the front wing profiles have been defined, they must be trimmed by the virtual endplate surface defined in Article 3.3.5, and the portion of the front wing profiles outboard of that surface must be discarded. Where the front wing profiles intersect the front wing endplate, a maximum fillet radius of 10mm may be applied.

3.3.7 Adjustability of front wing

Once the Front Wing Profiles have been defined in accordance with Article 3.3.6, a portion of up to four of the rearmost profiles and the gurney, may be adjustable in order to trim the front wing aerodynamic load.

For this purpose:

- a. The parts of the front wing profiles that are included within the adjustable part must have no degrees of freedom between them.
- b. The adjustment may only be a rotation about a fixed axis. In plan view, this axis must not subtend an angle greater than 20deg to the diagonal line described in Article 3.3.3 (a), and in front view it must not subtend an angle greater than 15deg to the horizontal plane. For the full extent of the adjustable part of the profiles outboard of a plane that lies 400mm from the car centre plane, and in any longitudinal vertical plane, this axis must lie between two vertical lines, one that passes through the forward most point of the adjustable part of the profiles in that section, and another one 30mm behind the first line.
- c. The junction between the adjustable and non-adjustable parts of the profiles must be defined by one or two surfaces of revolution about the fixed axis of rotation defined in 3.3.7 b. Furthermore, any normal to these surfaces of revolution may not subtend an angle greater than 55° to a line that is normal to the car centre plane. These surfaces of revolution must also lie inboard of the virtual endplate surface defined in Article 3.3.5.
- d. The original position of these profiles (as defined in accordance with Article 3.3.6) must be included within the overall range of adjustment. Furthermore, the maximum deviation for any point of these profiles between the uppermost and lowermost angle of adjustment must not exceed 35mm.
- e. Minimal exceptions to the geometrical criteria of Article 3.3.6 for the wing profiles may be made in the junction between the adjustable and non-adjustable parts, in order to ensure the necessary level of sealing. Such parts must lie within 3mm from one of the two surfaces of revolution and their maximum size must be the minimum necessary amount required to achieve a 20mm overlap between the adjustable and the non-adjustable parts of the profiles over the whole range of movement.

For the avoidance of doubt, the adjustment permitted under this Article is only allowed when the car is stationary and by the use of a tool, and in accordance with the Formula 1 Sporting Regulations.

Furthermore, any such variation of incidence maintains compliance with all of the bodywork regulations, with the exception of Articles 3.3.6 (a) and 3.3.6 (b).

3.3.8 Front wing strakes

Strakes may be constructed once the front wing profiles have been defined. For each strake, a virtual strake surface must be first defined, which must:

- a. Be connected to the non-adjustable part of the front wing profiles.
- b. Lie in its entirety between two vertical longitudinal planes, 20mm apart, and between 500mm and 800mm from the car centre plane.
- c. Lie entirely between 75mm and 150mm from the reference plane.
- d. Not be closer than 50mm in any point to the other such virtual strake surface.

- e. In no place have a normal which subtends an angle greater than 10° to an axis normal to the car centre plane.
- f. Contain no more than one curve when intersected by any lateral vertical or horizontal plane. In side view, no part of the virtual strake surface may obstruct any other part of it.

Once the virtual strake surface has been defined, the strake itself must:

- g. Fully enclose the entire virtual strake surface.
- h. In no part lie vertically above the upper surface of the front wing profiles defined in Article 3.3.6.
- i. Be no more than 6mm distant from the virtual strake surface, except its rear-most 100mm (measured in the longitudinal direction), where this maximum distance must not exceed 3mm.

Once the actual strake volume has been defined, a fillet radius of up to 5mm will be permitted where this strake volume intersects the individual profiles described in Article 3.3.6.

3.3.9 Front wing auxiliary components

The following components will be permitted in addition to the bodywork defined in Articles 3.3.5, 3.3.6 and 3.3.8 for primarily mechanical, structural or measurement reasons:

- a. Two brackets which define the pivot axis of the adjustable part of the front wing profile, and allow the necessary movement. These brackets must:
 - i. be in their entirety within 40mm from both the stationary and the adjustable part of the profiles over the whole range of adjustment
 - ii. be no more than 5mm thick. A fillet radius no greater than 2mm will be permitted where these brackets join the two profiles
 - iii. have no dimension that exceeds 80mm
- b. Up to sixteen (in total, per side) slot gap separator brackets which connect consecutive front wing profiles. These brackets must:
 - i. be in their entirety within 30mm from both of the two profiles they support in relation to each other
 - ii. be no more than 5mm thick. A fillet radius no greater than 2mm will be permitted where these brackets join the two profiles
 - iii. have no dimension that exceeds 60mm
- c. A mechanism with or without a fairing to contain it for the angle adjustment of part of the front wing profiles, as defined in Article 3.3.7. This mechanism and fairing must fit within a cuboid of which is 25mm wide, 60mm long and 60mm high. This cuboid may have a free orientation in space, but must intersect both the stationary and the adjustable part of the profiles for the entire range of adjustment.
- d. A fairing that contains a single tyre temperature sensor. The entire fairing and sensor must:
 - i. fit in the union between two volumes, a cuboid which is 15mm wide, 60mm long and 50mm high and a circular cylinder which has a base diameter of 30mm and a height of 60mm. The axis of the cylinder must coincide with the major axis of the one of the 15mm x 60mm faces of the cuboid.
 - ii. be symmetrical about a plane which is parallel to the 50mm x 60mm faces of the cuboid, and
 - iii. intersect either the profiles defined in Article 3.3.6 or the endplate defined in Article 3.3.5. A fillet radius no greater than 5mm will be permitted along the periphery of this intersection.

Furthermore, all the components listed above must not be visible from below, with the front wing endplates defined in Article 3.3.5 and the front wing strakes defined in Article 3.3.8 removed, and must lie inboard of the virtual endplate surface defined in Article 3.3.5.

Should there be a requirement for any additional component to be added, a team must write specifically to the FIA with an explanation, design, and calculated aerodynamic effect, in order to get approval. Such a communication will be circulated to rival teams if deemed to cover a new aspect that had previously not been considered.

3.4 Front bodywork

3.4.1 Nose shape

Only a single section, which must be open, may be contained within any longitudinal vertical cross section taken parallel to the car centre plane forward of a point 150mm ahead of the front wheel centre line, less than 250mm from the car centre plane and more than 125mm above the reference plane.

Any cameras or camera housings approved by the FIA (and the parts used to attach these to the bodywork up to a width of 15mm in the direction perpendicular to the car centre plane), in addition to a single inlet aperture for the purpose of driver cooling, such aperture having a maximum projected surface area of 1,500mm² and being situated forward of the section referred to in Article 15.5.6(a), will be exempt from the above.

3.4.2 Nose and chassis maximum height

Referring to the planes defined in Article 15:

No bodywork which is less than 250mm from the car centre plane may lie:

- a. Above a plane defined by a line on A-A parallel to and 550mm above the reference plane and a line on D-D parallel to and 220mm above the reference plane, if between A-A and D-D (with the exception of pitot tubes and antennae.).
- b. More than 220mm above the reference plane, if ahead of D-D.

With the exception of a transparent windscreen, antennae, pitot tubes, and the high speed camera defined in Article 8.8.6, no bodywork situated between the planes A-A and a plane parallel to and 380mm forward of the plane C-C may lie more than 625mm above the reference plane.

Any bodywork situated above the impact absorbing structure defined by Article 15.5.6 or above the survival cell, and forward of the plane B-B, must be of prescribed laminate, details of this laminate may be found in the Appendix to the Technical and Sporting Regulations.

3.4.3 Exclusion volume under the nose and chassis

In side view, there must be no bodywork in the area formed by two vertical lines, one 425mm behind the front wheel centre line, one 450mm ahead of the front wheel centre line, one diagonal line intersecting the vertical lines at 100mm and 135mm above the reference plane respectively, and one horizontal line on the reference plane.

3.4.4 Exclusion volume around the front wheels

In plan view, there must be no bodywork in the area enclosed by the intersection of the following lines:

- a. A longitudinal line parallel to and 1000mm from the car centre plane.
- b. A transverse line 450mm forward of the front wheel centre plane.
- c. A diagonal line running rearwards and outwards, from a point 875mm forward of the front wheel centre line and 250mm from the car centre plane, at an angle of 28° to the car centre plane.
- d. A transverse line 875mm forward of the front wheel centre plane.

- e. A longitudinal line parallel to and 165mm from the car centre plane.
- f. A diagonal line running forwards and inwards, from a point 430mm rearward of the front wheel centre line and 240mm from the car centre plane, at an angle of 4.5° to the car centre plane.
- g. A diagonal line from 430mm rearward of the front wheel centre line and 240mm from the car centre plane to 550mm forward of the plane C-C and 1000mm from the car centre plane.

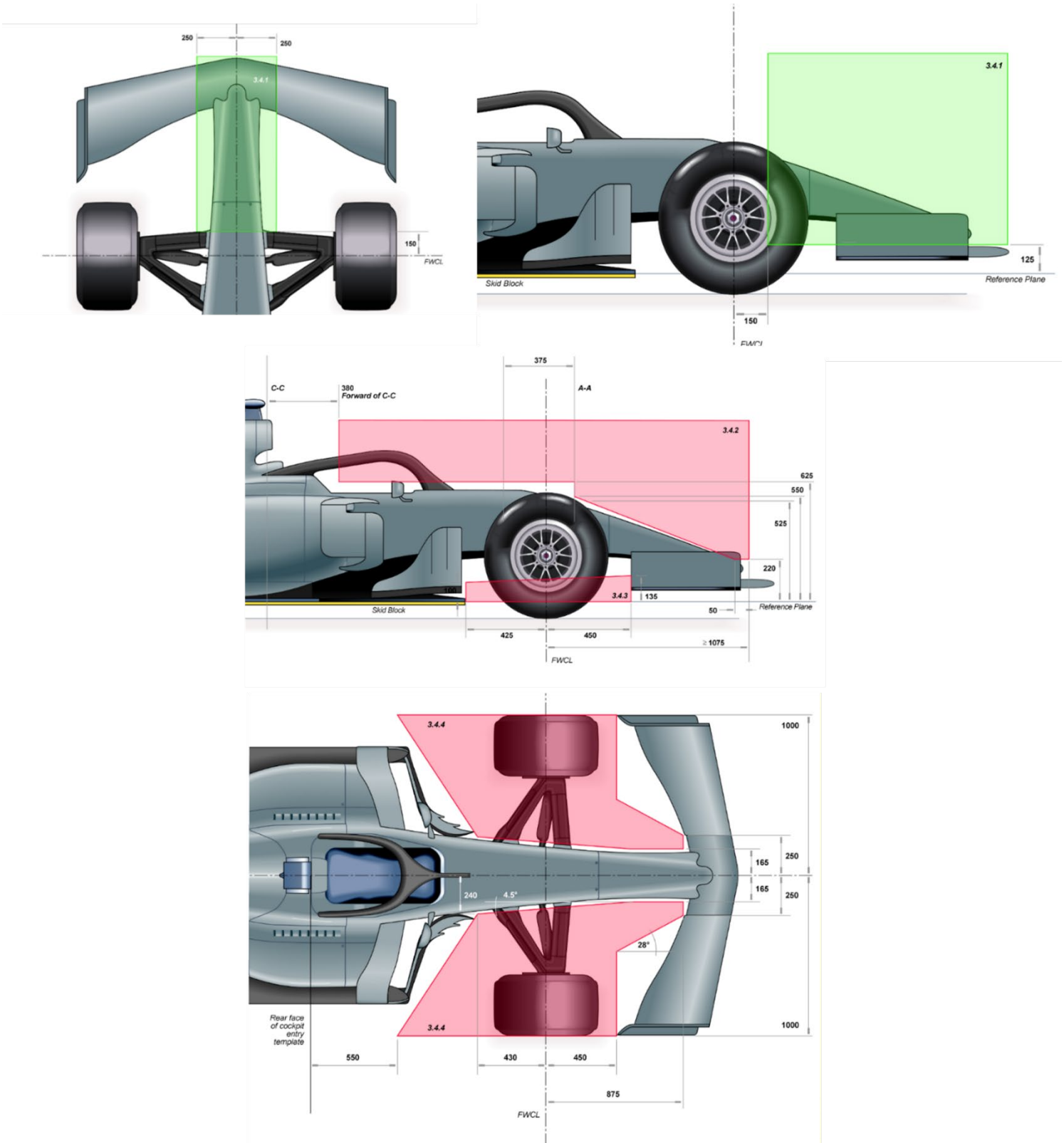

3.5 Rear bodywork

3.5.1 Engine cover

- a. With the exception of the opening described in Article 15.2.7, when viewed from the side, the car must have bodywork in the area bounded by four lines: one vertical 1330mm forward of the rear wheel centre line, one horizontal 550mm above the reference plane, one horizontal 925mm above the reference plane and one diagonal which intersects the 925mm horizontal at a point 1000mm forward of the rear wheel centre line and the 550mm horizontal at a point lying 50mm forward of the rear wheel centre line.

Bodywork within this area must be arranged symmetrically about the car centre plane and, when measured 200mm vertically below the diagonal boundary line, must have minimum widths of 150mm and 50mm respectively at points lying 1000mm and 50mm forward of the rear wheel centre line. This bodywork must lie on or outside the boundary defined by a linear taper between these minimum widths.

- b. Bodywork lying vertically above the area defined in section (a) of the present Article may be no wider than 125mm and must be arranged symmetrically about the car centre plane.
- c. When viewed from the side, no bodywork forward of the rear wheel centre line may lie above a line parallel to the diagonal boundary defined in a) and intersecting the rear wheel centre line 650mm above the reference plane.
- d. In side view, the projected area of any bodywork lying between 550mm and 730mm above the reference plane and between 200mm and 450mm forward of the rear wheel centre line must be greater than 44,990mm².

3.5.2 Sidepods height

- a. No bodywork situated more than 330mm behind the front wheel centre line and more than 330mm forward of the rear wheel centre line, which is more than 600mm above the reference plane, may be more than 350mm from the car centre plane.
- b. No bodywork between the rear wheel centre line and a line 800mm forward of the rear wheel centre line, which is more than 375mm from the car centre plane, may be more than 500mm above the reference plane.
- c. No bodywork between the rear wheel centre line and a line 400mm forward of the rear wheel centre line, which is more than 375mm from the car centre plane, may be more than 300mm above the reference plane.

3.5.3 Side impact structures

The impact absorbing structures defined by Article 15.5.2 must be fully enclosed by bodywork, such that no part of the impact structure is in contact with the external air flow. When cut by a longitudinal vertical plane, the bodywork enclosing these impact structures must not form closed sections in the region between 300mm and 875mm forward of the plane C-C.

3.5.4 Sidepods leading edge

No part of the area enclosed by the intersection of the following lines, on a plane 500mm above and parallel to the reference plane, may be visible from directly above the car:

- a. A longitudinal line parallel to and 580mm from the car centre plane.
- b. A longitudinal line parallel to and 320mm from the car centre plane.
- c. A lateral line parallel to and 550mm forward of the plane C-C.
- d. A diagonal line running rearwards and outwards, from a point 550mm forward of the plane C-C and 505mm from the car centre plane, at an angle of 75° to the car centre plane.

- e. A diagonal line running rearwards and outwards, from a point 400mm forward of the plane C-C and 320mm from the car centre plane, at an angle of 75° to the car centre plane.

3.5.5 Exclusion volume ahead of the sidepods

In plan view, there must be no bodywork, in the area enclosed by the intersection of the following lines:

- a. A longitudinal line parallel to and 700mm from the car centre plane.
- b. A longitudinal line parallel to and 320mm from the car centre plane.
- c. A diagonal line running rearwards and outwards, from a point 700mm forward of the plane C-C and 320mm from the car centre plane, at an angle of 75° to the car centre plane.
- d. A diagonal line running rearwards and outwards, from a point 625mm forward of the plane C-C and 320mm from the car centre plane, at an angle of 75° to the car centre plane.

3.5.6 Bargeboard height

No bodywork which, in plan view, is in the area enclosed by the intersection of the following lines may be more than 350mm above the reference plane:

- a. A longitudinal line parallel to and 800mm from the car centre plane.
- b. A diagonal line running rearwards and outwards, from a point 430mm rearward of the front wheel centre line and 240mm from the car centre plane, at an angle of 4.5° to the car centre plane.
- c. A transverse line 430mm rearward of the front wheel centre plane.
- d. A line running through a point 625mm forward of the plane C-C and 320mm from the car centre plane, running parallel to the diagonal line defined in Article 3.5.5(c).

3.5.7 Bodywork shape (R75 rule)

Any vertical cross section of bodywork parallel to the plane C-C situated in the volumes defined below must form one tangent continuous curve on its external surface. This tangent continuous curve may not contain any radius less than 75mm for volumes (a) to (g) and any radius less than 25mm for volume (h) only:

- a. The volume between 175mm forward of the rear wheel centre line and 300mm rearward of the plane C-C, which is more than 25mm from the car centre plane and more than 100mm above the reference plane.
- b. The volume between 100mm and 300mm rearward of plane C-C, which is more than 400mm from the car centre plane and more than 100mm above the reference plane.
- c. The volume between 100mm and 300mm rearward of plane C-C, which is between 125mm and 400mm from the car centre plane and between 100mm and 500mm above the reference plane.
- d. The volume between 100mm and 300mm rearward of plane C-C, which is between 125mm and 400mm from the car centre plane and more than 695mm above the reference plane.
- e. The volume between 100mm rearward of the plane C-C and 300mm forward of the plane C-C, which is more than 390mm from the car centre plane and more than 100mm above the reference plane.
- f. The volume between 100mm rearward of the plane C-C and 450mm forward of the plane C-C, which is more than 125mm from the car centre plane and more than 695mm above the reference plane.

- g. The volume between 50mm and 175mm forward of the rear wheel centre line, which is more than 25mm from the car centre plane and more than 175mm above the reference plane.
- h. The volume between 100mm and 300mm rearward of plane C-C, which is between 125mm and 400mm from the car centre plane and between 500mm and 695mm above the reference plane.

The surfaces lying within these volumes, which are situated more than 55mm forward of the rear wheel centre line, must not contain any apertures (other than those permitted by Article 3.5.8) or contain any vertical surfaces which lie parallel to the plane C-C.

3.5.8 Apertures

Once the relevant bodywork surfaces are defined in accordance with Article 3.5.7, apertures, any of which may adjoin or overlap each other, may be added for the purpose of allowing suspension members and driveshafts to protrude through the bodywork. Only one aperture may be added for each suspension member and no such aperture may have an area greater than 12,000mm² when projected onto the surface itself. No point on an aperture may be more than 200mm from any other point on the aperture.

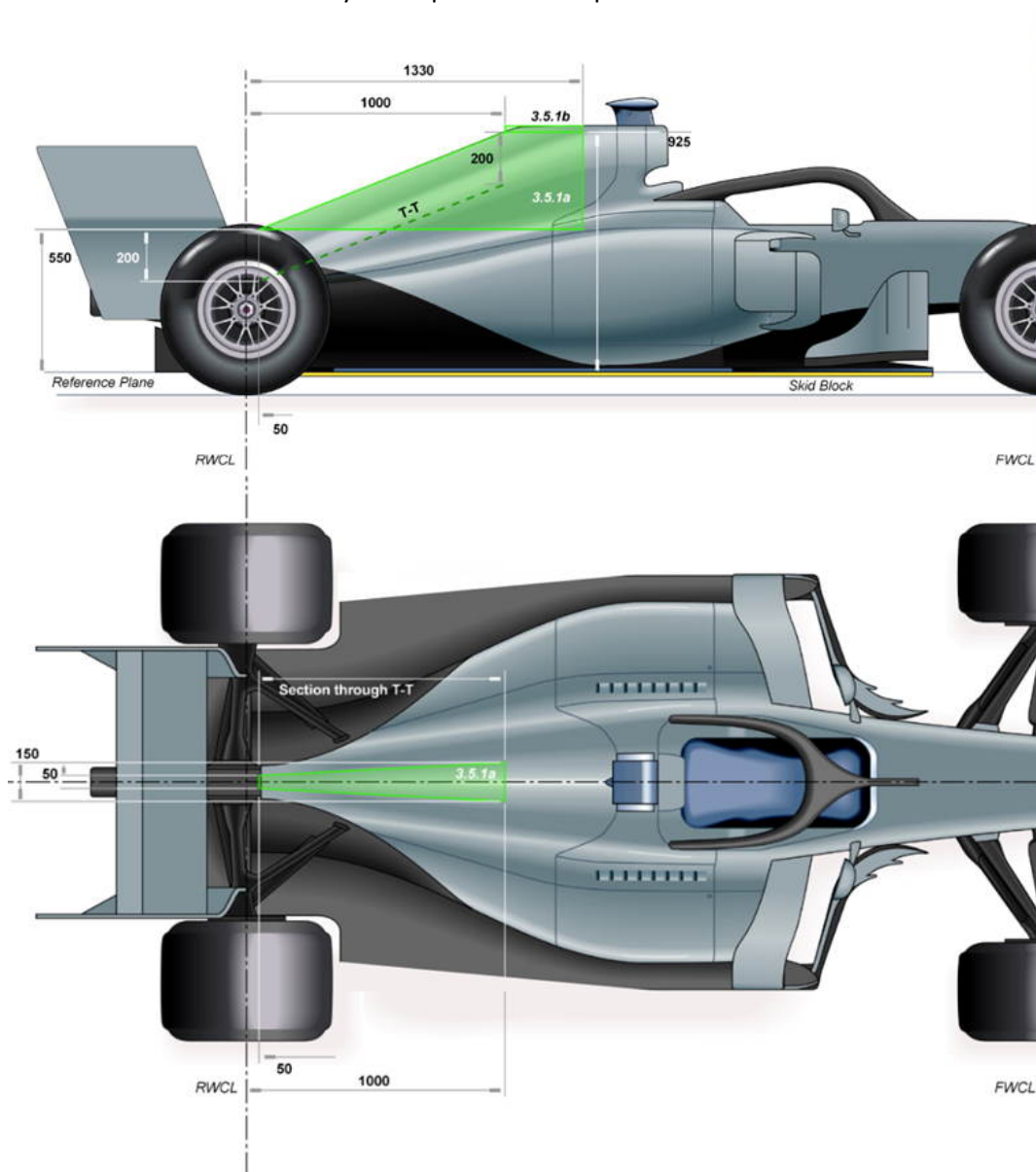

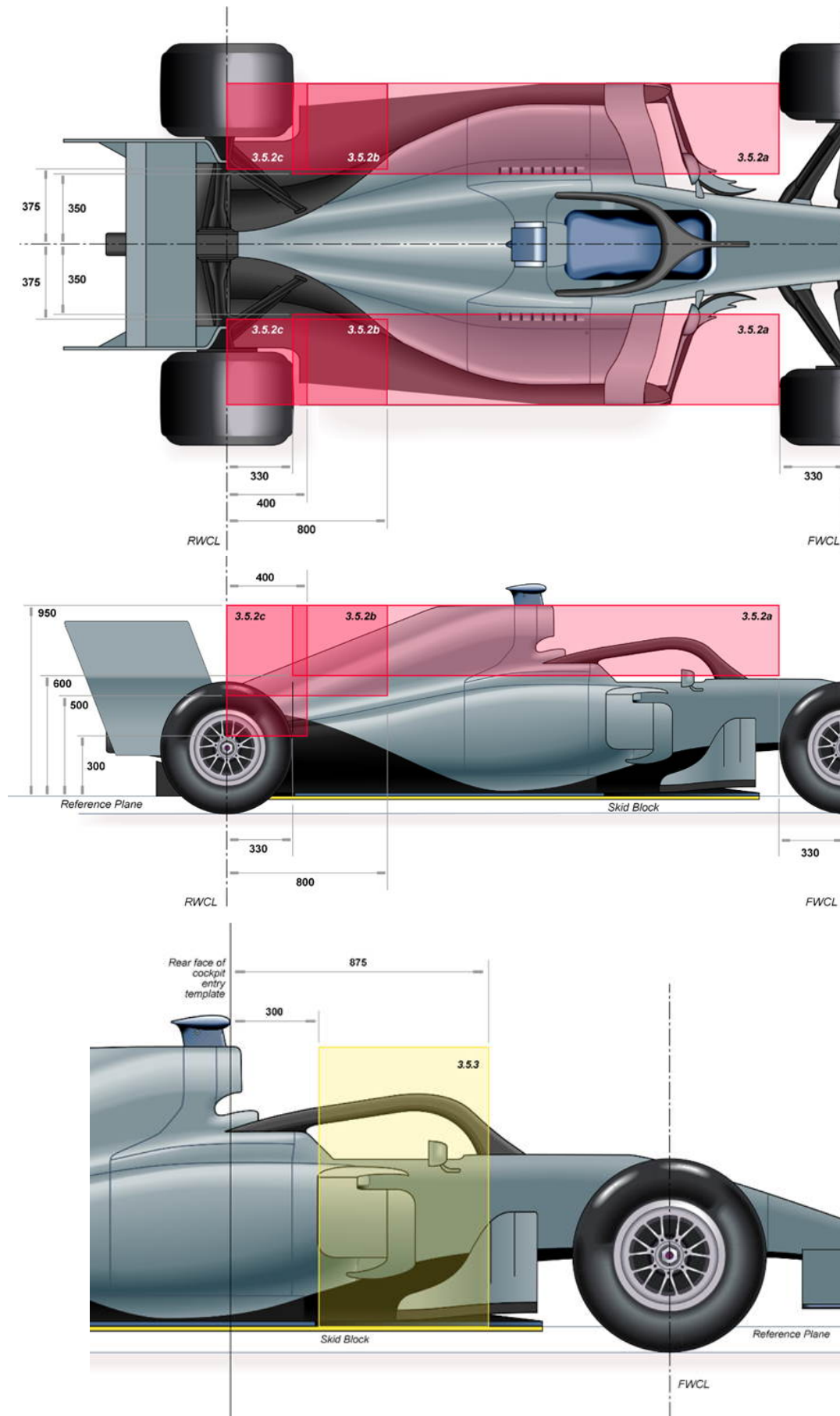

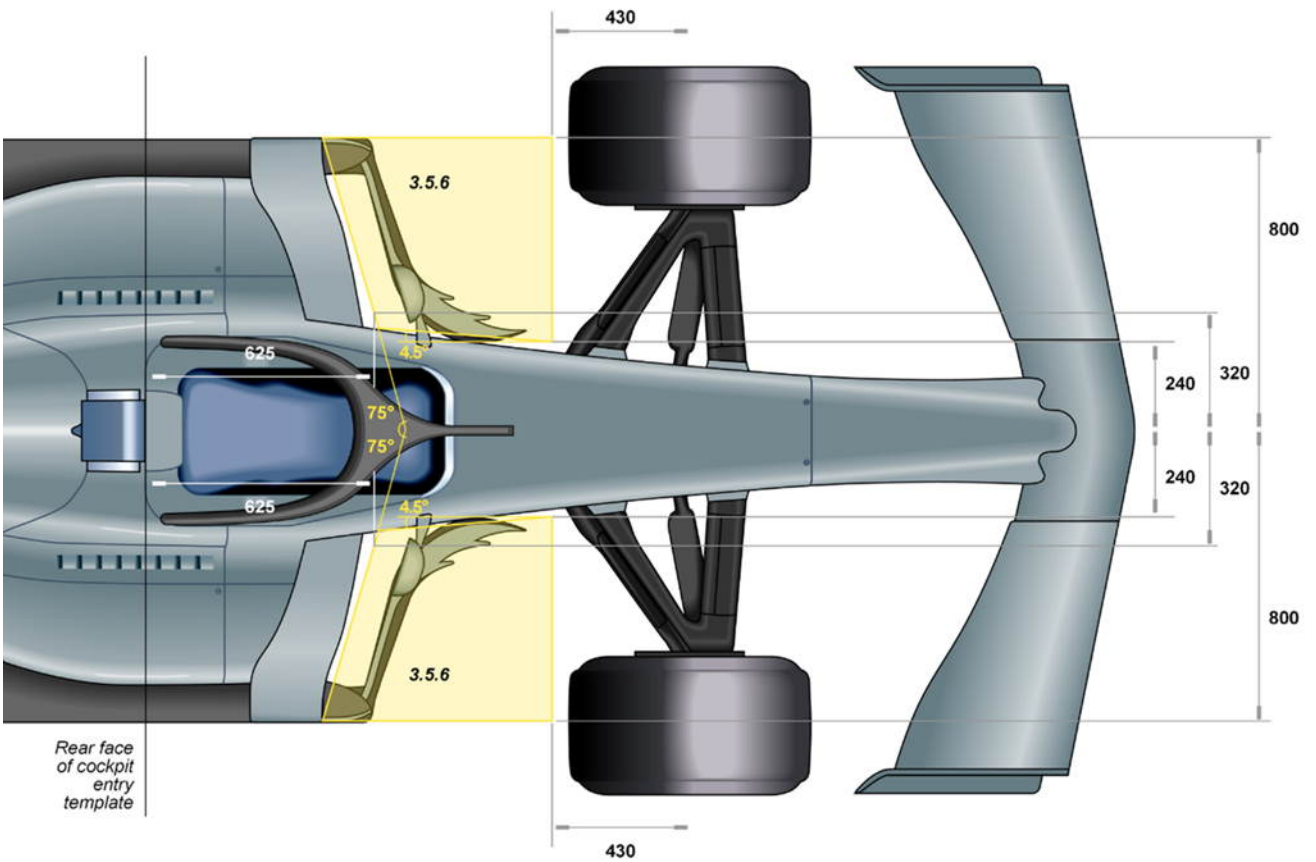
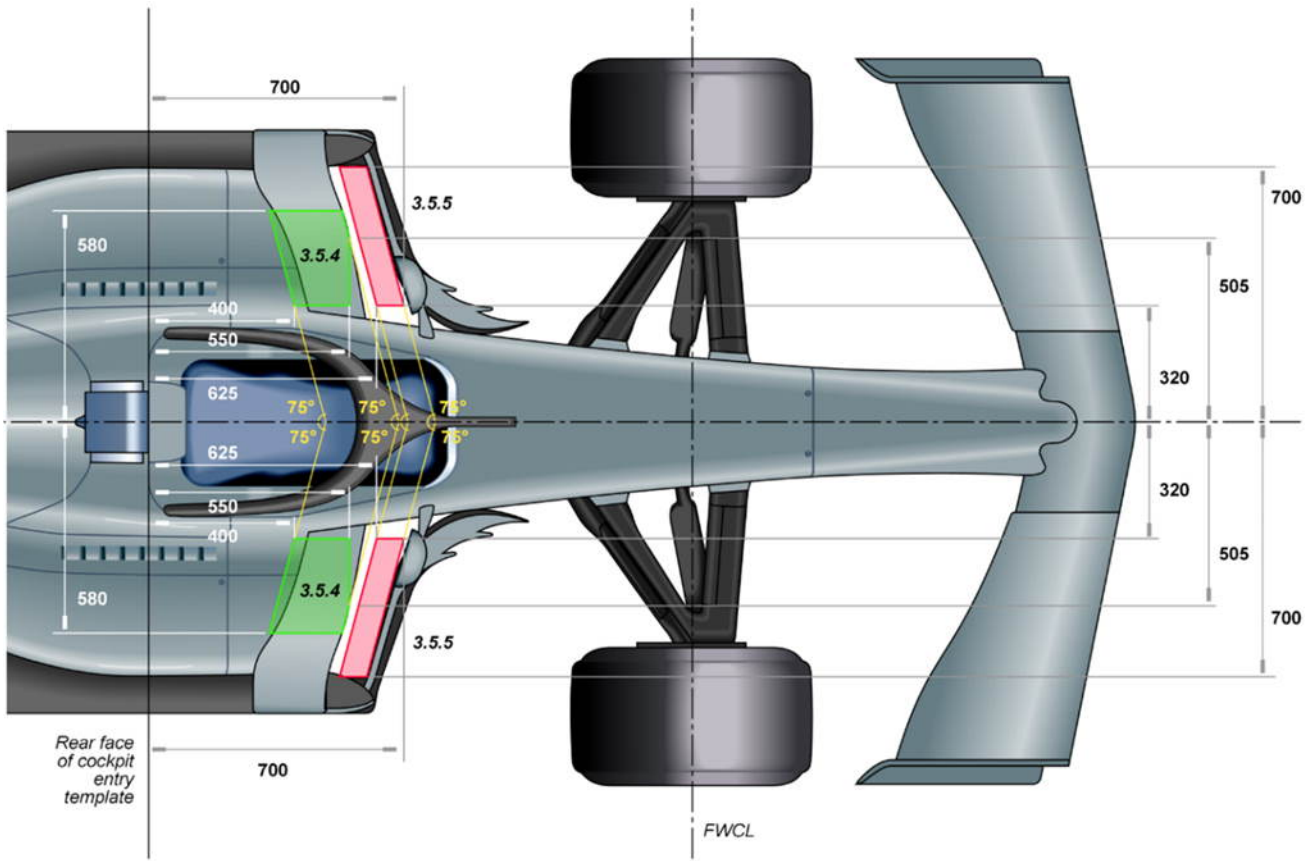

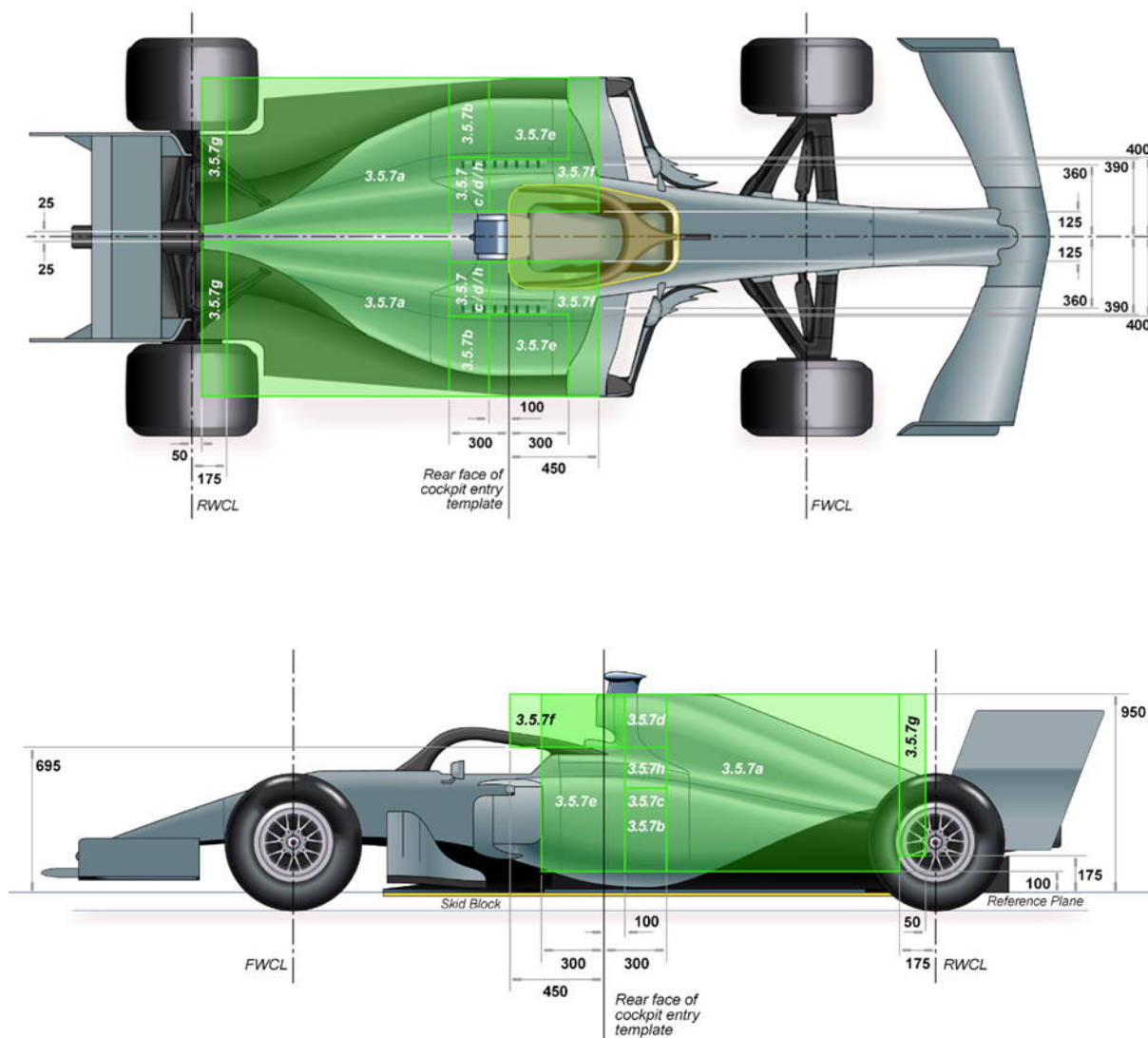

3.6 Rear wing and rear impact structure

3.6.1 Height

With the exception of the minimal parts solely associated with adjustment of the rear wing described under 3.6.8, no part of the bodywork behind the rear wheel centre line may be more than 870mm above the reference plane.

3.6.2 Width

- a. The width of bodywork behind the rear wheel centre line and more than 500mm above the reference plane must not exceed 1050mm.
- b. The width of bodywork behind the rear wheel centre line and between 200mm and 500mm above the reference plane must not exceed 840mm.

3.6.3 Rear wing profiles

Other than the bodywork defined in Article 3.6.6, any bodywork behind the rear wheel centre line which is more than 650mm above the reference plane, and less than 505mm from the car centre plane, must lie in an area when viewed from the side of the car that is situated between 150mm and 500mm rearward of the rear wheel centre line.

With the exception of the bodywork associated with adjustment of the section in accordance with Article 3.6.8:

- a. When viewed from the side of the car, no longitudinal vertical cross section may have more than two sections in this area, each of which must be closed.
- b. No part of these longitudinal vertical cross sections in contact with the external air stream may have a local concave radius of curvature smaller than 100mm.

Any bodywork associated with the adjustment of the rearmost section in accordance with Article 3.6.8 must be located either less than 25mm from the longitudinal centre line of the car and less than 900mm above the reference plane or more than 500mm from the longitudinal centre line of the car and less than 870mm above the reference plane.

Once the rearmost and uppermost section is defined, 'gurney' type trim tabs may be fitted to the trailing edge, **or within 40mm of the trailing edge if fitted to the lower surface**. When measured in any longitudinal vertical cross section no dimension of any such trim tab may exceed 20mm. **With the exception of the discontinuity at their two ends, 'gurney' trim tabs fitted onto the lower surface of the section must all be of the same height, inclination and chordwise position along their span.**

The chord of the rearmost and uppermost closed section must always be smaller than the chord of the lowermost section at the same lateral station.

Furthermore, the distance between adjacent sections at any longitudinal vertical plane must lie between 10mm and 15mm at their closest position, except, in accordance with Article 3.6.8, when this distance must lie between 10mm and 85mm when the DRS system is deployed.

3.6.4 Separators

In order to ensure that the individual profiles and the relationship between these two sections can only change whilst the car is in motion in accordance with Article 3.6.8, they must be bridged by means of pairs of rigid impervious supports arranged such that no part of the trailing edge of the forward section may be more than 255mm laterally from a pair of supports. These pairs of supports must:

- a. Be located no more than 505mm from the car centre plane.
- b. Fully enclose each complete section such that their inner profiles match that of each section. With the exception of minimal local changes where the two sections are adjacent to each other, their outer profiles must be offset from the inner profiles by between 8mm and 30mm and may not incorporate any radius smaller than 10mm ('gurney' type trim tabs may however be fitted between the supports).
- c. Be aligned as a pair so as to provide a bearing across their full thickness and along a profile length of at least 10mm when the distance between the two sections is at its closest position.
- d. Not be recessed into the wing profiles (where a recess is defined as a reduction in section at a rate greater than 45° with respect to a lateral axis).
- e. Be arranged so that any curvature occurs only in a horizontal plane (other than when this bodywork is adjusted in accordance with Article 3.6.8).
- f. Be between 2mm and 5mm thick.
- g. Be rigidly fixed to their respective sections.
- h. Be constructed from a material with modulus greater than 50GPa.

These supports will be ignored when assessing whether the car is in compliance with Articles 3.6.1, 3.6.3, 3.6.5, 3.6.6 and 3.6.7.

3.6.5 Rear impact structure

Any parts of the car less than 100mm from the car centre plane and more than 500mm behind the rear wheel centre line must be situated between 200mm and 400mm above the reference plane and no more than 710mm behind the rear wheel centre line.

With the exception of the last 150mm of the tailpipes described in Article 5.8, there must be no bodywork in an area less than 100mm from the car centre plane, more than 200mm

behind the rear wheel centre line and between 400mm and 600mm above the reference plane.

3.6.6 Pylons

Any horizontal section between 600mm and 650mm above the reference plane, taken through bodywork located rearward of a point lying 50mm forward of the rear wheel centre line and less than 100mm from the car centre plane, may contain no more than two closed symmetrical sections with a maximum total area of 5000mm². The thickness of each section may not exceed 25mm when measured perpendicular to the car centre plane.

Once fully defined, the section at 645mm above the reference plane may be extruded upwards to join the sections defined in Article 3.6.3. A fillet radius no greater than 10mm may be used where these sections join.

3.6.7 Endplates

- a. In side view, the projected area of any bodywork lying between 300mm and 870mm above the reference plane and between the rear wheel centre line and a point 810mm behind it and more than 400mm from the car centre plane must be greater than 280,000mm².
- b. Any bodywork behind the rear wheel centre line, more than 100mm from the car centre plane, and between 200mm and 650mm above the reference plane must lie in an area more than 400mm from the car centre plane. On any horizontal section through the bodywork in this area, at any given longitudinal position along this section, the distance between the inner and outer surfaces must not exceed 20mm measured perpendicular to the car centre line.
- c. In side view, no bodywork rearward of the rear wheel centre line, and between 100mm and 525mm from the car centre plane, may be situated vertically above a diagonal line which has the forward point 370mm above the reference plane and on the rear wheel centre line and the rearward point 870mm above the reference plane and 190mm rearward of the rear wheel centre line.
- d. In side view, no bodywork rearward of the rear wheel centre line, and between 100mm and 525mm from the car centre plane, may be situated rearward of a diagonal line which has the forward point 200mm above the reference plane and 550mm rearward of the rear wheel centre line and the rearward point 870mm above the reference plane and 810mm rearward of the rear wheel centre line.
- e. In an area lying behind the rear wheel centre line, more than 100mm from the car centre plane, and more than 600mm above the reference plane, any intersection of any bodywork visible from the side of the car with a horizontal or lateral vertical plane must form one continuous line which is visible from the side of the car.

3.6.8 Drag reduction system (DRS)

The incidence of the rearmost and uppermost closed section described in Article 3.6.3 may be varied whilst the car is in motion provided:

- a. It comprises only one component that must be symmetrically arranged about the car centre plane with a minimum width of 1008mm.
- b. With the exception of minimal parts solely associated with adjustment of the section, no parts of the section in contact with the external airstream may be located any more than 505mm from the car centre plane.
- c. With the exception of any minimal parts solely associated with adjustment of the rearmost and uppermost section, two closed sections are used in the area described in Article 3.6.3.
- d. Any such variation of incidence maintains compliance with all of the bodywork regulations.

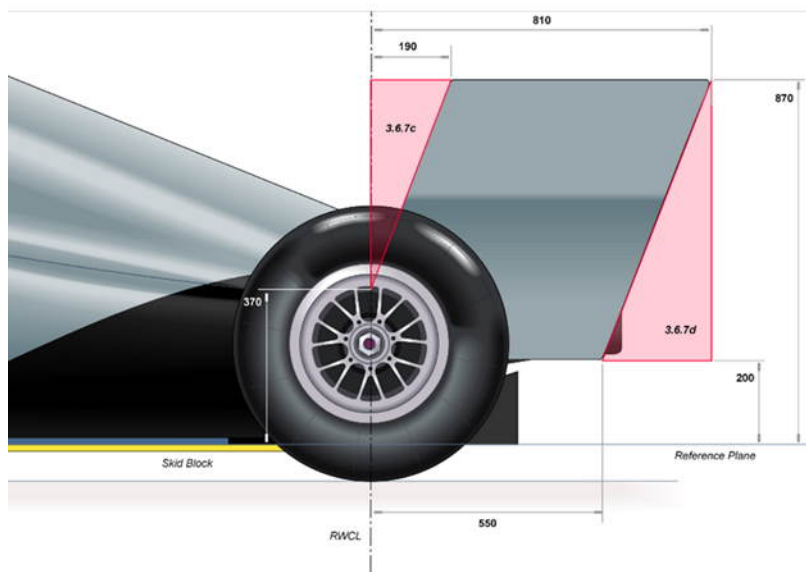
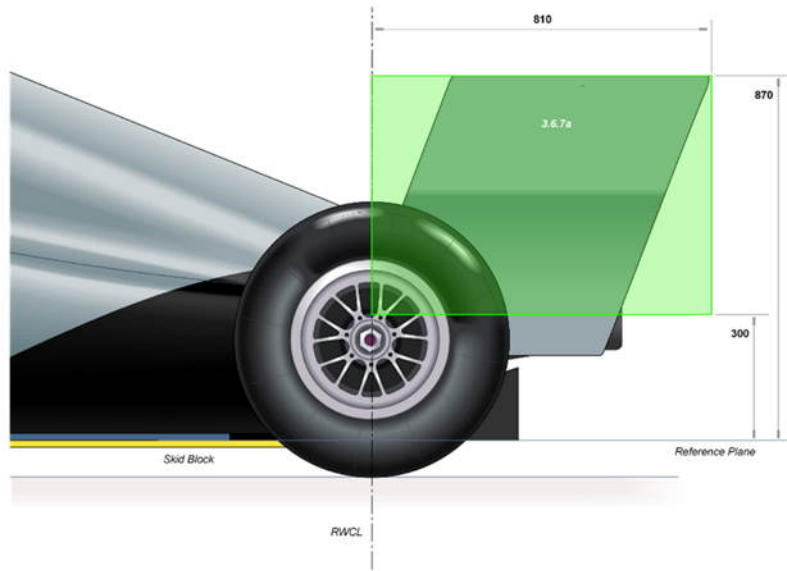
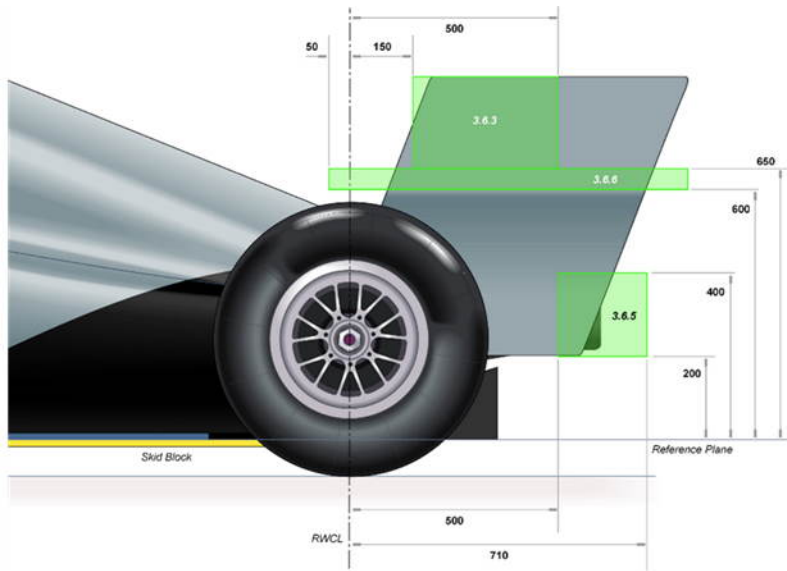

3.7 Floor and diffuser

Compliance with this Article must be demonstrated with all unsprung parts of the car removed.

3.7.1 Step and reference planes

With the parts referred to in Articles 3.7.11, 3.7.12 and 3.7.13 removed all sprung parts of the car situated from 430mm behind the front wheel centre line to 175mm in front of the rear wheel centre line, and which are visible from underneath, must form surfaces which lie on one of two parallel planes, the reference plane or the step plane.

The step plane must be 50mm above the reference plane.

Additionally, the surface formed by all parts lying on the reference plane must:

- a. Cover the area which is bounded by two transversal lines, one 430mm behind the front wheel centre line and the other on the rear wheel centre line, and two longitudinal lines 150mm either side of the car centre plane.
- b. Have a maximum width of 500mm.
- c. Be symmetrical about the car centre plane.
- d. Have a 50mm radius (+/-2mm) on each front corner when viewed from directly beneath the car, this being applied after the surface has been defined.

3.7.2 Exclusion volume around the rear wheels

In plan view, there must be no bodywork in the area enclosed by the intersection of the following lines:

- a. A longitudinal line parallel to and 800mm from the car centre plane.
- b. The rear wheel centre line.
- c. A diagonal line passing through the points at:
 - i. the plane C-C and 800mm from the car centre plane.
 - ii. the rear wheel centre line and 650mm from the car centre plane.

3.7.3 Transition

The surface lying on the reference plane must be joined around its periphery to the surfaces lying on the step plane by a vertical transition. If there is no surface visible on the step plane vertically above any point around the periphery of the reference plane, this transition is not necessary.

3.7.4 Boundaries

The surface lying on the reference plane may be curved upwards at its boundaries with an arc of constant curvature whose radius of curvature is no greater than 25mm, with no inflection, which is tangential to the surface and applied perpendicular to the boundary. In no case may the arc start further than 25mm from the boundary (when measured on the surface and perpendicular to this boundary).

Where the vertical transition meets the surfaces on the step plane a radius no greater than 25mm is permitted (a radius in this context will be considered as an arc of constant curvature applied perpendicular to the boundary and tangential to both surfaces).

The surfaces lying on the step plane which do not meet one of the vertical transitions may be curved upwards at their boundaries with an arc whose radius of curvature is no greater than 100mm at any point, with no inflection, which is tangential to the surface and applied perpendicular to the boundary. In no case may the arc start further than 100mm from the boundary (when measured on the surface and perpendicular to this boundary).

The surface lying on the reference plane, the surfaces lying on the step plane, the vertical transitions between them and any surfaces rearward of the surfaces lying on the reference or step planes, must first be fully defined before any radius can be applied or the parts referred

to in Articles 3.7.11, 3.7.12 and 3.7.13 fitted. Any radius applied is still considered part of the relevant surface.

3.7.5 Floor construction

All parts lying on the reference and step planes, in addition to the transition between the two planes, must produce uniform, solid, hard, continuous, rigid (no degree of freedom in relation to the unit comprising the survival cell/power unit/gearbox), impervious surfaces under all circumstances.

3.7.6 Tolerances

To help overcome any possible manufacturing problems, and not to permit any design which may contravene any part of these regulations, the following dimensional tolerances are permitted on bodywork situated between 430mm behind the front wheel centre line and the rear wheel centre line: a vertical tolerance of +/- 3mm is permissible across the surfaces lying on the reference and step planes and a horizontal tolerance of 3mm is permitted when assessing whether a surface is visible from beneath the car.

3.7.7 Diffuser width

The width of bodywork behind the rear wheel centre line and less than 200mm above the reference plane must not exceed 1050mm.

3.7.8 Diffuser length

No part of the car between 100mm and 525mm from the car centre plane and less than 200mm above the reference plane may be more than 350mm behind the rear wheel centre line.

3.7.9 Diffuser height and construction

- a. No bodywork which is visible from beneath the car which lies between 175mm forward of the rear wheel centre line and 350mm rearward of the rear wheel centre line and is less than 450mm above the reference plane may be more than 175mm above the reference plane.

Additionally, any bodywork in this area must produce uniform, solid, hard, continuous (no fully enclosed holes), rigid (no degree of freedom in relation to the unit comprising the survival cell/power unit/gearbox), impervious surfaces under all circumstances.

- b. All sprung parts of the car situated behind a line 175mm in front of the rear wheel centre line, which are visible from underneath and are more than 250mm from the car centre plane, must be at least 50mm above the reference plane.

3.7.10 Continuity

- a. In an area lying 450mm or less from the car centre plane, and from 450mm forward of the plane C-C to 350mm rearward of the rear wheel centre line, any intersection of any bodywork visible from beneath the car with a lateral or longitudinal vertical plane should form one continuous line which is visible from beneath the car.
- b. In an area lying 800mm or less from the car centre plane, and from 450mm forward of the plane C-C to 175mm forward of the rear wheel centre line, any intersection of any bodywork visible from beneath the car with a lateral or longitudinal vertical plane should form one continuous line which is visible from beneath the car.
- c. All bodywork that is visible from beneath the car and less than 50mm above the reference plane, within 250mm of the car centre plane and situated behind a line 175mm ahead of the rear wheel centre line, must produce only a single, continuous curve when intersected with any horizontal plane

3.7.11 Plank

Beneath the surface formed by all parts lying on the reference plane, a rectangular plank, with a 50mm radius (+/-2mm) on each front corner, must be fitted. This plank may comprise

no more than three pieces, the forward one of which may not be any less than 900mm in length, but must:

- a. Extend longitudinally from a point lying 430mm behind the front wheel centre line to the rear wheel centre line.
- b. Have a width of 300mm with a tolerance of +/- 2mm.
- c. Be made from an homogeneous material with a specific gravity between 1.3 and 1.45, or if pocketed be made from a bonded assembly the upper 0.5mm of which must have a specific gravity of between 1.3 and 1.65 and the remainder, excluding pockets, be made from an homogeneous material with a specific gravity of between 1.3 and 1.45.
- d. Have a thickness of 10mm with a tolerance of +/-1mm.
- e. Have a uniform thickness when new.
- f. With the exception of the area lying between 400mm and 800mm forward of the plane C-C, pocketing of the lower 9.5mm of the plank from above is permitted more than 630mm behind the front wheel centre line. However, the pocket depth may not reduce the remaining plank material thickness to less than 2mm from either the lowest surface below the reference plane when new or the lower surface of any recesses necessary to fit the skids permitted by Article 3.7.12. Furthermore, the periphery of any pocket, in any horizontal plane parallel to the reference plane, must be not less than 10mm from either the edges of the plank or any holes or recesses in the plank. In vertical cross section the internal pocket fillet radii must be at least 3mm and in horizontal cross section 10mm. Pockets may only be filled with a material having a specific gravity of less than 0.25.
- g. Have no other holes or cut outs other than those necessary to fit the skids permitted by Article 3.7.12 or the fasteners permitted by Article 3.7.13, or those holes specifically mentioned in h) below.
- h. Have seven precisely placed holes the positions of which are detailed in Drawing 1. In order to establish the conformity of the plank assembly after use, its thickness will only be measured in the four 50mm diameter holes and the two forward 80mm diameter holes, regardless of whether plank or skid material is present (see Article 3.7.12(a)).

Four further 10mm diameter holes are permitted provided their sole purpose is to allow access to the bolts which secure the Accident Data Recorder to the survival cell.
- i. Be fixed symmetrically about the car centre plane in such a way that no air may pass between the complete plank assembly and the surface formed by the parts lying on the reference plane.

The lower edge of the periphery of the plank may be chamfered at an angle of 30° to a depth of 8mm, the trailing edge however may be chamfered over a distance of 200mm to a depth of 8mm.

3.7.12 Skids

The lower surface of the plank may be fitted with flush mounted metal skids which:

- a. May only be fitted in place of plank material.
- b. Have a total area no greater than 20000mm² when viewed from directly beneath the car.
- c. Are no greater than 4000mm² in area individually when viewed from directly beneath the car.
- d. Are fitted in order that their entire lower surfaces are visible from directly beneath the car.
- e. Must have a minimum cross sectional thickness of 15mm across its external boundaries in plan view.

The minimum wall thickness between an internal fixing hole and the external boundaries of the skid must be no less than 7.5mm.

- f. Must have an upper surface no more than 3mm below the reference plane.
- g. Must be designed such that they are secured to the car using the fasteners described in Article 3.7.13 and that, when viewed from directly beneath the car, no part of the skid is more than 50mm from the centre line of a fastener which passes through that skid.
- h. Must be made from Titanium alloy.

3.7.13 Plank and skids mounting

The plank and skids must be fixed to the car using fasteners which:

- a. Are no smaller than M6 and are made from grade 12.9 or 10.9 steel.
- b. If used to attach a skid to the car, must employ at least 1 fastener per 1,000mm² of skid area.
- c. If used to attach a skid to the car, the team must be able to show by calculation that the shanks of the fasteners (which may be no less than 6mm diameter) are the weakest point in the attachment of the skids to the car.
- d. May use a load spreading washer if required.

The total area of the fasteners and any load spreading washers employed with them when viewed from directly beneath the car must be less than 7,500mm². The area of any single fastener plus its load-spreading washer may not exceed 500mm².

No part of any fastener or load-spreading washer may be more than 8mm below the reference plane. For the avoidance of doubt, the skids referred to in Article 3.7.12 will not be treated as load spreading washers.

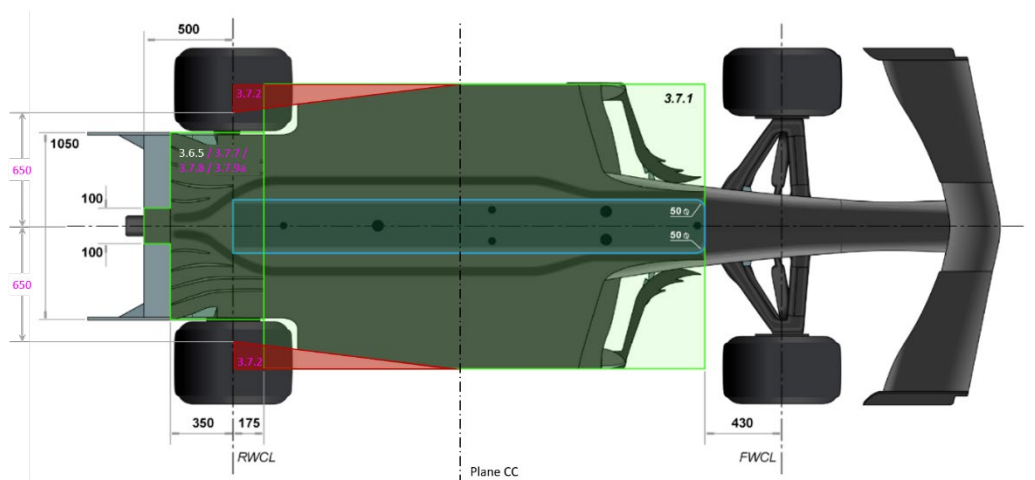

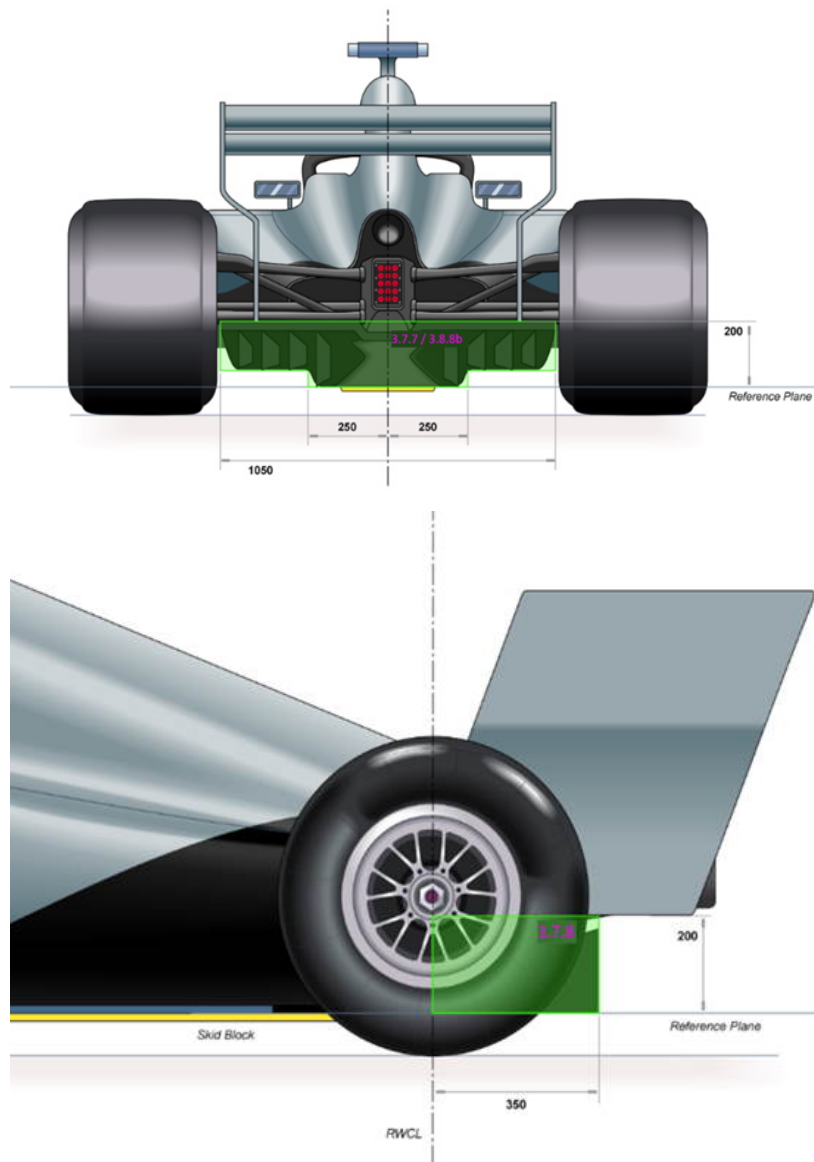

3.8 Aerodynamic influence

With the exception of the parts described in Articles 11.4, 11.5 and 11.6, and the rear view mirrors described in Article 14.3, any specific part of the car influencing its aerodynamic performance:

- a. Must comply with the rules relating to bodywork.
- b. Must be rigidly secured to the entirely sprung part of the car (rigidly secured means not having any degree of freedom).

With the exception of the driver adjustable bodywork described in Article 3.6.8 (in addition to minimal parts solely associated with its actuation) and the parts described in Articles 11.4, 11.5 and 11.6, any specific part of the car influencing its aerodynamic performance must remain immobile in relation to the sprung part of the car.

Any device or construction that is designed to bridge the gap between the sprung part of the car and the ground is prohibited under all circumstances.

No part having an aerodynamic influence and no part of the bodywork, with the exception of the parts referred to in Articles 3.7.11, 3.7.12 and 3.7.13, may under any circumstances be located below the reference plane.

With the exception of the parts necessary for the adjustment described in Article 3.6.8, any car system, device or procedure which uses driver movement as a means of altering the aerodynamic characteristics of the car is prohibited.

3.9 Bodywork flexibility

3.9.1 Bodywork may deflect no more than 15mm vertically when a 1000N load is applied vertically to it at points 700mm and 1000mm forward of the front wheel centre line and 895mm from the car centre plane. The load will be applied symmetrically to both sides of the car, and in a downward direction using a 50mm diameter ram on a rectangular adapter measuring 400mm x 150mm. This adapter must be supplied by the team and:

- a. Have a flat top surface without recesses.
- b. Be fitted to the car so as to apply the full load to the bodywork at the test point and not to increase the rigidity of the parts being tested.
- c. Be placed with the inner 400mm edge parallel to the car centre plane and displaced from it by 820mm.
- d. Be placed with its forward edge 1050mm forward of the front wheel centre line.

The deflection will be measured along the loading axis at the bottom of the bodywork at this point and relative to the reference plane.

The same test described in the present Article will be also applied asymmetrically (i.e. on the one side of the car only), and in this case the bodywork may not deflect more than 20mm.

3.9.2 Bodywork may deflect no more than 8mm vertically when a 500N load is applied vertically to it 450mm forward of the rear wheel centre line and 600mm from the car centre plane. The load will be applied in a downward direction using a 50mm diameter ram and an adapter of the same size. Teams must supply the latter when such a test is deemed necessary.

3.9.3 Bodywork may deflect by no more than one degree horizontally when a load of 1000N is applied simultaneously to its extremities in a rearward direction 825mm above the reference plane and 20mm forward of the forward edge of the rear wing endplate at 825mm above the reference plane.

3.9.4 Bodywork may deflect no more than 3mm vertically when a 500N load is applied simultaneously to each side of it 250mm behind the rear wheel centre line, 375mm from the car centre plane and 890mm above the reference plane. The deflection will be measured at the outer extremities of the bodywork at a point 395mm behind the rear wheel centre line.

The load will be applied in a downward direction through pads measuring 200mm x 100mm which conform to the shape of the bodywork beneath them, and with their uppermost horizontal surface 890mm above the reference plane. The load will be applied to the centre of area of the pads. Teams must supply the latter when such a test is deemed necessary.

3.9.5 Bodywork may deflect no more than 5mm vertically when a 4000N load is applied vertically to it at three different points which lie on the car centre plane and 100mm either side of it. Each of these loads will be applied in an upward direction at a point 480mm rearward of the front wheel centre line using a 50mm diameter ram in the two outer locations and a 70mm diameter ram on the car centre plane.

Stays or structures between the front of the bodywork lying on the reference plane and the survival cell may be present for this test, provided they are completely rigid and have no system or mechanism which allows non-linear deflection during any part of the test.

Furthermore, the bodywork being tested in this area may not include any component which is capable of allowing more than the permitted amount of deflection under the test load (including any linear deflection above the test load), such components could include, but are not limited to:

- a. Joints, bearings pivots or any other form of articulation.
- b. Dampers, hydraulics or any form of time dependent component or structure.

- c. Buckling members or any component or design which may have any non-linear characteristics.
 - d. Any parts which may systematically or routinely exhibit permanent deformation.
- 3.9.6 The uppermost aerofoil element lying behind the rear wheel centre line may deflect no more than 7mm horizontally when a 500N load is applied horizontally. The load will be applied 870mm above the reference plane at three separate points which lie on the car centre plane and 270mm either side of it. The loads will be applied in a rearward direction using a suitable 25mm wide adapter which must be supplied by the relevant team.
- 3.9.7 The forward-most aerofoil element lying behind the rear wheel centre line and which lies more than 630mm above the reference plane may deflect no more than 2mm vertically when a 200N load is applied vertically. The load will be applied in line with the trailing edge of the element at any point across its width.

The loads will be applied using a suitable adapter, supplied by the relevant team, which:

- a. May be no more than 50mm wide.
 - b. Which extends no more than 10mm forward of the trailing edge.
 - c. Incorporates an 8mm female thread in the underside.
- 3.9.8 Any part of the trailing edge of any front wing flap may deflect no more than 5mm, when measured along the loading axis, when a 60N point load is applied normal to the flap.
- 3.9.9 In order to ensure that the requirements of Article 3.8 are respected, the FIA reserves the right to introduce further load/deflection tests on any part of the bodywork which appears to be (or is suspected of), moving whilst the car is in motion.

3.10 Bodywork construction

- 3.10.1 In order to avoid the spread of debris on the track following an accident, the outer skins of the front wing endplates and any turning vanes in the vicinity of the front wheels (and any similarly vulnerable bodywork parts in this area), must be made predominantly from materials which are included for the specific purpose of containing debris.

The FIA must be satisfied that all such parts are constructed in order to achieve the stated objective.

3.11 Datum Points

To allow development of the scrutineering process for 2022, cars should be fitted with a number of datum points

A recommended installation, using FIA provided optical targets, is given in the Appendix to the Technical and Sporting Regulations.

With prior approval, teams may use a custom solution which satisfies the General Requirements for target visibility given in the Appendix to the Technical and Sporting Regulations. In such a case, the team will be responsible for providing optical targets, associated mountings and a file containing the positions of the targets relative to the survival cell.

For 2021 only and with prior approval, minimal exceptions to Article 13.1.1 and Article 3 will be allowed for mountings associated with this installation.

ARTICLE 4: WEIGHT

4.1 Minimum weight

The weight of the car, without fuel, must not be less than 752kg at all times during the Event.

If, when required for checking, a car is not already fitted with dry-weather tyres, it will be weighed on a set of dry-weather tyres selected by the FIA technical delegate.

4.2 Weight distribution

The weight applied on the front and rear wheels must not be less than the weight specified in Article 4.1 factored by 0.455 and 0.535 respectively at all times during the qualifying practice session. Rounding will be to nearest 0.5kg.

If, when required for checking, a car is not already fitted with dry-weather tyres, it will be weighed on a set of dry-weather tyres selected by the FIA technical delegate.

4.3 Weight of tyres

The weight limit specified in Article 4.1 and the factors specified in Article 4.2 will be adjusted up or down according to any differences (rounded up to the nearest 1kg for Article 4.1) between the total set and individual axle set weights respectively of the dry-weather tyres used in the Championship taking place in the calendar year referred to in the title and the preceding year's Championship.

4.4 Ballast

Ballast can be used provided it is secured in such a way that tools are required for its removal. It must be possible to fix seals if deemed necessary by the FIA technical delegate.

Ballast designated for the sole purpose of achieving the driver weight specified in Article 4.6.2 must:

- a. Be entirely located to the car between the front and rear extent of the cockpit entry template.
- b. Be attached securely to the survival cell and sealed by the FIA.
- c. Be clearly identified.

A nominal such weight of 10kg should be present for the impact test described in Article 16.3.

4.5 Adding during the race:

With the exception of compressed gases, no substance may be added to the car during the race. If it becomes necessary to replace any part of the car during the race, the new part must not weigh any more than the original part.

4.6 Weight of the driver:

4.6.1 The weight of the driver with his seat and driving equipment will be established by the FIA technical delegate at the first Event of the Championship, this reference weight may be amended at any time during the Championship season if deemed necessary by the FIA technical delegate. This reference weight will be used to establish the minimum weight of the driver and ballast referred to in Article 4.6.2 below.

4.6.2 The reference weight of the driver will be added to the weight of any ballast designated for this purpose and, at no time during the Event, may this be less than 80kg.

ARTICLE 5: POWER UNIT

5.1 Engine specification

- 5.1.1 Only 4-stroke engines with reciprocating pistons are permitted.
- 5.1.2 Engine cubic capacity must be 1600cc (+0/-10cc).
- 5.1.3 Crankshaft rotational speed must not exceed 15000rpm.
- 5.1.4 Fuel mass flow must not exceed 100kg/h.
- 5.1.5 Below 10500rpm the fuel mass flow must not exceed $Q \text{ (kg/h)} = 0.009 N(\text{rpm}) + 5.5$.
- 5.1.6 At partial load, the fuel mass flow must not exceed the limit curve defined below:
- $Q \text{ (kg/h)} = 10$ when the engine power is below -50kW
 - $Q \text{ (kg/h)} = 0.257 \times \text{engine power (kW)} + 22.85$ when the engine power is above -50kW
- 5.1.7 Pressure charging may only be effected by the use of a sole single stage compressor linked to a sole single stage exhaust turbine by a shaft assembly parallel to the engine crankshaft and within 25mm of the car centre plane. The shaft must be designed so as to ensure that the shaft assembly, the compressor and the turbine always rotate about a common axis and at the same angular velocity, an electrical motor generator (MGU-H) may be directly coupled to it. The shaft may not be mechanically linked to any other device.
- 5.1.8 All engines must have six cylinders arranged in a 90° "V" configuration and the normal section of each cylinder must be circular.
- All six cylinders must be of equal capacity.
- 5.1.9 Engines must have two inlet and two exhaust valves per cylinder.
- Only reciprocating poppet valves with axial displacement are permitted.
- The sealing interface between the moving valve component and the stationary engine component must be circular.
- 5.1.10 Engine exhaust gases may only exit the cylinder head through outlets outboard of the cylinder bore centre line and not from within the "V" centre.
- 5.1.11 The crankshaft may only have three connecting rod bearing journals.
- 5.1.12 An insert within a PU component is a minimal, non-dismountable part whose function is solely to locally support a function of this component. The total volume of inserts within the component cannot be more than 10% of the total volume of the component.
- 5.1.13 All power unit breather fluids may only vent to atmosphere and must pass through an orifice which is positioned rearward of the rear axle centre line and less than 400mm above the reference plane and less than 100mm from the car centre plane. No breather fluids may re-enter the power unit.

5.2 Other means of propulsion and energy recovery

- 5.2.1 The use of any device, other than the engine described in 5.1 above, and one MGU-K, to propel the car, is not permitted.
- 5.2.2 Energy flows, power and ES state of charge limits are defined in the energy flow diagram shown in Appendix 3 of these regulations.

When the car is on the track a lap will be measured on each successive crossing of the timing line, however, when entering the pits the lap will end, and the next one will begin, at the start of the pit lane (as defined in the F1 Sporting Regulations).

Electrical DC measurements will be used to verify that the energy and power requirements are being respected.

A fixed efficiency correction of 0.95 will be used to monitor the maximum MGU-K power.

- 5.2.3 The MGU-K must be solely and permanently mechanically linked to the powertrain before the main clutch. This mechanical link must be of fixed speed ratio to the engine crankshaft.
- The rotational speed of the MGU-K may not exceed 50,000rpm.
- The weight of the MGU-K (as defined in line 12 of Appendix 2 to these regulations) may not be less than 7kg.
- The maximum torque of the MGU-K may not exceed 200Nm. The torque will be referenced to the crankshaft speed and the fixed efficiency correction defined in Article 5.2.2 will be used to monitor the maximum MGU-K torque.
- The laminate thickness of the MGU-K may not be less than 0.05mm.
- 5.2.4 The MGU-H must be solely mechanically linked to the pressure charging system. This mechanical link must be of fixed speed ratio to the exhaust turbine and may be clutched.
- The rotational speed of the MGU-H may not exceed 125,000rpm.
- The weight of the MGU-H (as defined in line 14 of Appendix 2 to these regulations) may not be less than 4kg.
- 5.2.5 Cars must be fitted with homologated sensors which provide all necessary signals to the FIA data logger in order to verify the requirements above are being respected.

5.3 Power unit dimensions

- 5.3.1 Cylinder bore diameter must be 80mm (+/- 0.1mm).
- 5.3.2 The crankshaft centre line must lie on the car centre plane and 90mm (+/-0.5mm) above the reference plane. The power unit may only transmit torque to the gearbox by means of a single output shaft that must be co-axial with the crankshaft. The output shaft must rotate clockwise when viewed from the front of the car.
- 5.3.3 Valve stem diameter must not be less than 4.95mm.
- 5.3.4 The crankshaft main bearing journal diameter (measured on the crankshaft) must not be less than 43.95 mm.
- 5.3.5 The crankshaft crank pin bearing journal diameter (measured on the crankshaft) must not be less than 37.95mm.
- 5.3.6 No cylinder of the engine may have a geometric compression ratio higher than 18.0.
- 5.3.7 All elements of the power unit specified in the relevant column of the table in Appendix 2 of these regulations must be installed in the union of the volumes that exist between two vertical planes parallel to C-C separated by 700mm and in a box 150mm long, 250mm wide and 800mm high which lies symmetrically about the car centre plane immediately ahead of the front vertical plane.
- 5.3.8 Power unit mountings may only comprise six M12 studs for connection to the survival cell and either four or six M12 studs for connection to the transmission. These studs may be fitted on the survival cell, power unit or transmission. The installed end of the studs must be M12 and the free end may be a different diameter.

The mounting faces of the studs for connection to the survival cell must lie on the forward of the two planes described in Article 5.3.7 and be located at Y215/Z15(2), Y340/Z260(2) and Y175/Z420(2). All six of these studs must be used.

Four mounting faces of the studs for connection to the transmission must lie on one vertical plane parallel to C-C and be located at Y100/Z15(2) and Y255/Z345(2). All four of these studs must be used. Optionally, an additional two studs may be used, provided their coordinates are at Y150/Z140(2).

A tolerance of +/- 0.2mm will be permitted on all of the above dimensions, all dimensions refer to the centre of the studs.

The distance between the two planes is fixed at 480mm (+/-0.2mm).

Any part which provides an additional load path from the survival cell to the gearbox, with a connection to the power unit, may only do so if this is incidental to its principal purpose.

5.4 Weight and centre of gravity

- 5.4.1 The overall weight of the power unit must be a minimum of **150kg**.
- 5.4.2 The centre of gravity of the power unit may not lie less than 200mm above the reference plane.
- 5.4.3 The total weight of the part of the ES that stores energy, i.e. the cells (including any clamping plates) and electrical connections between cells, must be no less than 20kg and must not exceed 25kg.
- 5.4.4 The weight of a piston (with piston-pin, piston-pin retainers and piston rings) may not be less than 300g.
- 5.4.5 The weight of a connecting rod (with fasteners, small and big end bearings) may not be less than 300g.
- 5.4.6 The weight of the complete crankshaft assembly between the mid positions of the front and rear main bearing journals (including balance masses, bolts, bungs, O-rings between the boundaries), may not be less than 5300g. See drawing 8.
- 5.4.7 When establishing conformity with Articles 5.4.1, 5.4.2 and Appendix 4 of the F1 Sporting Regulations, the homologated power unit perimeter will be defined in accordance with the table shown in Appendix 2 of these regulations.

5.5 Power unit torque demand

- 5.5.1 The only means by which the driver may control acceleration torque to the driven wheels is via a single foot (accelerator) pedal mounted inside the survival cell.
- 5.5.2 Designs which allow specific points along the accelerator pedal travel range to be identified by the driver or assist him to hold a position are not permitted.
- 5.5.3 At any given engine speed the driver torque demand map must be monotonically increasing for an increase in accelerator pedal position.
- 5.5.4 At any given accelerator pedal position and above 4,000rpm, the driver torque demand map must not have a gradient of less than – (minus) 0.045Nm/rpm.

5.6 Power unit control

- 5.6.1 The maximum delay allowed, computed from the respective signals as recorded by the ADR or ECU, between the accelerator pedal position input signal and the corresponding output demands being achieved is 50ms.
- 5.6.2 Teams may be required to demonstrate the accuracy of the power unit configurations used by the ECU.
- 5.6.3 Power unit control must not be influenced by clutch position, movement or operation.
- 5.6.4 The idle speed control target may not exceed 4,000rpm.
- 5.6.5 A number of power unit protections are available in the ECU.
A minimum of nine seconds hold time should be configured for the power unit protections enabled during qualifying and race. The configuration of the air tray fire detection and throttle failsafe are exceptionally unrestricted in order to allow each team to achieve the best level of safety.
- 5.6.6 The power unit must achieve the torque demanded by the FIA standard software.
- 5.6.7 Homologated sensors must be fitted which measure the torque generated at the power unit output shaft and the torques supplied to each driveshaft. These signals must be provided to the ECU.

- 5.6.8 Engine plenum (as defined in line 4 of Appendix 2 to these regulations) air temperature must be more than ten degrees centigrade above ambient temperature. When assessing compliance, the temperature of the air will be the lap average recorded by an FIA approved and sealed sensor located in an FIA approved location situated in the engine plenum, during every lap of the qualifying practice session and the race. The first lap of the race, laps carried out whilst the safety car is deployed, laps with a time at least 20% greater than the fastest lap of the session, pit in and out laps and any laps that are obvious anomalies (as judged by the technical delegate) will not be used to assess the average temperature. The ambient temperature will be that recorded by the FIA appointed weather service provider. This information will also be displayed on the timing monitors.

5.7 Engine high rev limits

Engine high rev limits may vary for differing conditions provided all are contained within a band of 750rpm. However, a lower rev limit may be used when:

- a. The gearbox is in neutral.
- b. Stall prevention is active.
- c. The driver clutch request is greater than 95% of the total available travel of the driver clutch actuation device, used only to protect the engine following a driver error.
- d. An engine protection is active.
- e. The bite point finder strategy is active.
- f. The safety car is deployed or during the formation lap.

Except for the above conditions, power unit actuators may not be used to artificially control the power unit speed or alter the power unit response in a rev range more than 750rpm below the final rev limit.

5.8 Exhaust systems

- 5.8.1 With the exception of incidental leakage through joints (either into or out of the system) and power unit breather fluids, all and only the fluids entering the compressor inlet and fuel injectors must exit from the engine exhaust system.
- 5.8.2 Engine exhaust systems must have only a single turbine tailpipe exit and, **if a wastegate is present**, either one or two wastegate tailpipe exits which must all be rearward facing and through which all exhaust gases must pass. All and only the turbine exit exhaust gases must pass through the turbine tailpipe and all and only the wastegate exhaust gases must pass through the wastegate tailpipe(s). None of the tailpipes may be contained within any of the other tailpipes.
- 5.8.3 The cross-sectional area of the turbine tailpipe exit at the rearmost point of the turbine tailpipe must lie between 7500mm² and 14000mm², and the total cross-sectional area of the wastegate tailpipe exit(s), **if a wastegate is present**, at the rearmost point of the wastegate tailpipe(s) must lie between 1590mm² and 2375mm². If there are two wastegate tailpipe exits they must be equal in area.
- 5.8.4 The last 150mm of each tailpipe must in its entirety:
- a. Form a thin-walled unobstructed right circular cylinder with its axis +/- 5° to the car centre plane when viewed from above the car and between 0° and 5° (tail up) to the reference plane when viewed from the side of the car. The entire circumference of each exit should lie on a single plane normal to the tailpipe axis and be located at the rearmost extremity of the last 150mm of the tailpipe.
 - b. Be located between 350mm and 550mm above the reference plane.
 - c. Be located no more than 100mm from the car centre plane.

- d. Be positioned in order that the entire circumference of the exit of the tailpipe lies between two vertical planes parallel to C-C and which lie between 220mm and 235mm rearward of the rear wheel centre line.

5.8.5 There must be no bodywork lying within the right circular cylinders which:

- a. Share a common axis with that of the last 150mm of each tailpipe.
- b. Have a diameter 5mm greater than each tailpipe, starting at the exit of each tailpipe and extending rearwards as far as a point 600mm behind the rear wheel centre line.
- c. Have a diameter 30mm greater than each tailpipe, starting 2mm rearwards of the exit of each tailpipe and extending rearwards as far as a point 600mm behind the rear wheel centre line.

5.9 Variable geometry systems

5.9.1 With the exception of devices needed for control of pressure charging systems, variable geometry exhaust systems are not permitted. No form of variable geometry turbine (VGT) or variable nozzle turbine (VNT) or any device to adjust the gas throat section at the inlet to the turbine wheel is permitted.

5.9.2 Variable valve timing and variable valve lift profile systems are not permitted.

5.10 Fuel systems

5.10.1 The pressure of the fuel supplied to the fuel injectors may not exceed 500bar. Only approved parts may be used and the list of parts approved by the FIA, and the approval procedure, may be found in the Appendix to the Technical and Sporting Regulations.

5.10.2 There may only be one fuel injector per cylinder and no fuel injectors are permitted upstream of the intake valves or downstream of the exhaust valves. Only approved parts may be used and the list of parts approved by the FIA, and the approval procedure, may be found in the Appendix to the Technical and Sporting Regulations.

5.10.3 All cars must be fitted with two fuel flow meters, wholly within the fuel tank, which have been manufactured and calibrated by the FIA designated suppliers to specifications determined by the FIA. These sensors may only be installed and used as specified by the FIA. Furthermore, all fuel delivered to the power unit must pass through these homologated sensors, and must all be delivered to the combustion chambers by the fuel injectors described by Article 5.10.2.

5.10.4 Homologated sensors which directly measure the pressure and temperature of the fuel supplied to the fuel injectors must also be fitted, these signals must be supplied to the FIA data logger.

5.10.5 Any device, system or procedure the purpose and/or effect of which is to increase the flow rate or to store and recycle fuel after the measurement point is prohibited.

5.11 Ignition systems

5.11.1 Ignition is only permitted by means of a single ignition coil and single spark plug per cylinder. No more than five sparks per cylinder per engine cycle are permitted.

The use of plasma, laser or other high frequency ignition techniques is forbidden.

Only approved ignition coils may be used and the list of parts approved by the FIA, and the approval procedure, may be found in the Appendix to the Technical and Sporting Regulations.

5.11.2 Only conventional spark plugs that function by high tension electrical discharge across an exposed gap are permitted.

Spark plugs are not subject to the materials restrictions described in Articles 5.16 and 5.17.

5.12 Energy Recovery System (ERS)

- 5.12.1 The system will be considered shut down when no high voltage can be present on any external or accessible part of the ERS.

The shutdown process must take no longer than two seconds from activation.

It must be possible to shut down the ERS via the following means:

- a. The switch required by Article 14.2.1.
 - b. The switches required by Article 14.2.2.
 - c. The switch or button required by Article 9.4.
- 5.12.2 The ERS must shut down when the ECU required by Article 8.2 initiates an anti-stall engine shut off.
- 5.12.3 All cars must be fitted with two ERS status lights which:
- a. Have been supplied by an FIA designated manufacturer and fitted to the car in accordance with the instructions in the Appendix to these regulations.
 - b. Are in working order throughout the Event even if the main hydraulic, pneumatic or electrical systems on the car have failed.
 - c. Remain powered for at least 15 minutes if the car comes to rest with its engine stopped.
 - d. Are marked with a "HIGH VOLTAGE" symbol according to ISO3864 of at least 30mm along the triangle side and no more than 50mm away from the lights.
- 5.12.4 All cars must provide signals regarding the car operating and insulation states to the ADR in order to facilitate control of the ERS status lights.
- 5.12.5 The maximum peak voltage on the car must never exceed 1000V.
- 5.12.6 All elements of the power unit specified in Article 5.12.7 must be installed wholly within the survival cell.

The total weight of these elements (The weight considered is the sum of the individual weights of these elements) must be greater than the minimum weight of the same elements determined between all the homologated power units at the start of the 2017 season.

The volume occupied by these elements (The volume considered is the sum of the individual volumes occupied by these elements) must be greater than the minimum volume of the same elements determined between all the homologated power units at the start of the 2017 season.

- 5.12.7 The elements of the power unit that are considered for Article 5.12.6 are:
- a. ES elements as defined in lines 16 and 17 of Appendix 2 to these regulations.
 - b. Any DC-DC converter connected to ES HV DC bus. Includes active parts, enclosure, brackets and supports.
 - c. CU-K (MGU-K control unit). Includes active parts, enclosure, brackets and supports.
 - d. CU-H (MGU-H control unit). Includes active parts, enclosure, brackets and supports.
 - e. HV DC connections between ES and CU-K/CU-H/DC-DC converter. Includes all conductors, insulation, EMC screening, mechanical and thermal shielding.

5.12.8 ERS minimum weight and volume:

The procedure which will be used to determine the volume and weight of the power unit elements listed in Article 5.12.7 may be found in the Appendix to the Technical and Sporting Regulations.

The minimum values are:

- a. Minimum volume: 22.0 l.
- b. Minimum weight: 30.6kg.

5.13 Engine ancillaries

- 5.13.1 All coolant pumps, oil pumps, scavenge pumps, oil/air separators, hydraulic pumps and fuel pumps delivering more than 10bar must be mechanically driven directly from the engine and/or MGU-K with a fixed speed ratio.
- 5.13.2 Any pressure sensor used to measure pressure of any fluid necessary to ensure the power unit functions correctly at all times (including but not limited to coolant, oil, fuel and air) must be manufactured by FIA designated suppliers to a specification determined by the FIA. Cylinder pressure sensors are excluded from this requirement.
- 5.13.3 With the exception of exhaust temperature sensors and temperature sensors embedded in electronic boxes, any temperature sensor used to measure temperature of any fluid necessary to ensure the power unit functions correctly at all times (including but not limited to coolant, oil, fuel and air) must be manufactured by FIA designated suppliers to a specification determined by the FIA.

5.14 Engine intake air

- 5.14.1 With the exception of incidental leakage through joints or cooling ducts in the inlet system (either into or out of the system), all air entering the engine must enter the bodywork through a maximum of two inlets which are located:
- Between the front of the cockpit entry template and a point 500mm forward of the rear wheel centre line longitudinally.
 - No less than 200mm above the reference plane vertically.
 - On vertical cross-sections parallel to C-C.

Furthermore, any such inlets must be visible in their entirety when viewed from the front of the car without the driver seated in the car and with the secondary roll structure and associated fairing removed (see Article 15.2.6).

- 5.14.2 The addition of any substance other than fuel, as described in Article 5.10.3, into the air destined for combustion is forbidden. Exhaust gas recirculation is forbidden.

5.15 Materials and Construction – Definitions

- 5.15.1 X Based Alloy (e.g. Ni based alloy) – X must be the most abundant element in the alloy on a %w/w basis. The minimum possible weight percent of the element X must always be greater than the maximum possible of each of the other individual elements present in the alloy.
- 5.15.2 X-Y Based Alloy (e.g. Al-Cu based alloy) – X must be the most abundant element as in Article 5.15.1 above. In addition, element Y must be the second highest constituent (%w/w), after X in the alloy. The mean content of Y and all other alloying elements must be used to determine the second highest alloying element (Y).
- 5.15.3 Intermetallic Materials (e.g. TiAl, NiAl, FeAl, Cu₃Au, NiCo) – These are materials where the material is based upon intermetallic phases, i.e. the matrix of the material consists of greater than 50%v/v intermetallic phase(s). An intermetallic phase is a solid solution between two or more metals exhibiting either partly ionic or covalent, or metallic bonding with a long range order, in a narrow range of composition around the stoichiometric proportion.
- 5.15.4 Composite Materials – These are materials where a matrix material is reinforced by either a continuous or discontinuous phase. The matrix can be metallic, ceramic, polymeric or glass based. The reinforcement can be present as long fibres (fibre length greater than 13mm) or short fibres, whiskers and particles (discontinuous reinforcement). Nanoscale reinforced materials are to be considered as composites. (a reinforcement is considered to be nanoscale if any dimension of the reinforcement is less than 100nm.)
- 5.15.5 Metal Matrix Composites (MMC's) – These are composite materials with a metallic matrix containing a phase of greater than 2%v/v which is not soluble in the liquid phase of the metallic matrix.

5.15.6 Ceramic Materials (e.g. Al₂O₃, SiC, B₄C, Ti₅Si₃, SiO₂, Si₃N₄) – These are inorganic, non-metallic solids.

5.16 Materials and construction – General

5.16.1 Unless explicitly permitted for a specific application, the following materials may not be used anywhere on the power unit:

- a. Magnesium based alloys.
- b. Metal Matrix Composites (MMC's).
- c. Intermetallic materials.
- d. Alloys containing more than 5% by weight of Platinum, Ruthenium, Iridium or Rhenium.
- e. Copper based alloys containing more than 2.75% Beryllium.
- f. Any other alloy class containing more than 0.25% Beryllium.
- g. Tungsten base alloys.
- h. Ceramics and ceramic matrix composites.

5.16.2 The restrictions in Article 5.16.1 do not apply to coatings provided the total coating thickness does not exceed 25% of the section thickness of the underlying base material in all axes. In all cases, other than under Article 5.16.3(b), the relevant coating must not exceed 0.8mm.

Where the coating is based on Gold, Platinum, Ruthenium, Iridium or Rhenium, the coating thickness must not exceed 0.035mm.

5.16.3 The restrictions in Article 5.16.1(h) do not apply to the following applications:

- a. Any component whose primary purpose is for electrical or thermal insulation.
- b. Any coating whose primary purpose is for thermal insulation of the outside of the exhaust system.

5.16.4 Magnesium based alloys, where permitted, must be available on a non-exclusive basis and under normal commercial terms to all competitors. Only those alloys covered by ISO16220 or ISO3116 and approved by the FIA may be used.

5.17 Materials and construction – Components

5.17.1 Pistons must respect Article 5.16. Titanium alloys are not permitted.

5.17.2 Piston pins must be manufactured from an iron based alloy and must be machined from a single piece of material.

5.17.3 Connecting rods must be manufactured from iron or titanium based alloys and must be machined from a single piece of material with no welded or joined assemblies (other than a bolted big end cap or an interfered small end bush).

5.17.4 Crankshafts must be manufactured from an iron based alloy.

No welding is permitted between the front and rear main bearing journals.

No material with a density exceeding 18,400 kg/m³ may be assembled to the crankshaft.

These parts assembled to the crankshaft may be manufactured in a Tungsten based material.

5.17.5 Camshafts must be manufactured from an iron based alloy.

Each camshaft and lobes must be machined from a single piece of material.

No welding is allowed between the front and rear bearing journals.

5.17.6 Valves must be manufactured from intermetallic materials or from alloys based on Iron, Nickel, Cobalt or Titanium. Hollow valves (e.g. sodium, or similar, filled for cooling) are permitted, but the main cavity created must be a cylindrical feature of constant diameter.

Machined features to facilitate manufacture and assembly are allowed above and below the main cavity, however such features must not create a volume that extends beyond a virtual plain cylinder positioned on the valve centreline with a diameter which is 1.0 mm greater than that of the main cavity.

In addition, the restrictions detailed in Articles 5.16.2 and 15.1.2 do not apply to valves.

5.17.7 Reciprocating and rotating components:

- a. Reciprocating and rotating components must not be manufactured from graphitic matrix, metal matrix composites or ceramic materials, this restriction does not apply to the clutch and any seals.
- b. Rolling elements of rolling element bearings must be manufactured from an iron based alloy or from a ceramic material.
- c. All timing gears between the crankshaft and camshafts (including hubs) must be manufactured from an iron based alloy.
- d. High pressure fuel pumps elements may be manufactured from a ceramic material.
- e. Torsional damper elements may be manufactured in a Tungsten based material.

5.17.8 Static components:

- a. Other than inserts within them, engine crankcases including sump, cylinder heads and cylinder head cam covers must be manufactured from aluminium or iron alloys.
No composite materials or metal matrix composites are permitted either for the whole component or locally.
- b. Other than parts listed in a) above, magnesium based alloys are permitted for static parts which may not be changed without incurring a penalty under Article 5.22.
- c. Any metallic structure whose primary or secondary function is to retain lubricant or coolant within the engine must be manufactured from an iron based alloy, an aluminium alloy or a magnesium based alloy if permitted by Article 5.17.8(b).
- d. All threaded fasteners, other than the two exceptions below, must be manufactured from an alloy based on Cobalt, Iron or Nickel. The exceptions are:
 - i. Fasteners whose primary function requires them to be an electrical insulator may be manufactured from ceramic or polymeric materials.
 - ii. Fasteners that are used in electronic control units may be manufactured from aluminium or copper based alloys or polymeric (plastic) materials.

Composite materials are not permitted.

- e. Valve seat inserts, valve guides and any other bearing component may be manufactured from metallic infiltrated pre-forms with other phases which are not used for reinforcement.
- f. Ballast may be manufactured in a Tungsten based material.

5.18 Materials and construction – Pressure charging and exhaust systems

- 5.18.1 All components of the power unit exhaust system, (from the cylinder head up to and including turbine housing or waste-gate exit housing) that are in contact with the main exhaust gas flow must be manufactured from a Cobalt, Iron or Nickel based alloy. Any gaskets or seals are excluded from this restriction.
- 5.18.2 Any rotating and reciprocating component in the compressor (from compressor inlet to compressor outlet) must be manufactured from an aluminium, titanium or iron based alloy.
- 5.18.3 Static components that are neither in the exhaust system nor in the compressor line must be manufactured from iron based alloys, aluminium alloys or titanium alloys.
- 5.18.4 The compressor housing (from compressor inlet to compressor outlet) must be manufactured from aluminium or magnesium based alloys.

5.18.5 Measures must be taken to ensure that in the event of failure of the turbine wheel any resulting significant debris is contained within the car.

5.19 Materials and construction – Energy recovery, storage systems and electronic systems

5.19.1 All metallic casings for the energy recovery and storage systems must be manufactured in iron, aluminium or titanium based alloys and must comply with all aspects of Article 5.16 except for power electronic cooling base plate where metal matrix composite may be used.

5.19.2 All metallic casings for electronic systems, with the exception of metallic casings for the energy recovery and storage systems, must be manufactured in iron, aluminium, titanium or magnesium based alloys.

5.19.3 Energy storage devices are not subject to Articles 5.16.1a), b), c) and h) nor to 5.16.2.

5.19.4 Permanent magnets in electrical machines are not subject to Articles 5.16.1 a), b), c) or h) nor to Article 5.16.2.

5.19.5 Electronic components contained inside electronic units are not subject to any material restriction.

5.20 Starting the engine

A supplementary device temporarily connected to the car may be used to start the engine in the team's designated garage area, in the pit lane and on the grid.

5.21 Stall prevention systems

If a car is equipped with a stall prevention system, and in order to avoid the possibility of a car involved in an accident being left with the engine running, all such systems must be configured to stop the engine no more than ten seconds after activation.

The sole purpose of such systems is to prevent the engine stalling when a driver loses control of the car. If the car is in second gear or above when the system is activated multiple gear changes may be made to either first gear or neutral, under all other circumstances the clutch alone may be activated.

Each time such a system is activated the clutch must be fully disengaged and must remain so until the driver de-activates the system by manually operating the clutch with a request greater than 95% of the total available travel of the drivers clutch actuation device.

5.22 Replacing power unit parts

Refer to the table in Appendix 2 of these regulations.

The parts listed as "EXC" in the table referred to above may be changed without incurring a penalty under Article 23.3 of the F1 Sporting Regulations. If changing any of these parts involves breaking a seal this may be done but must be carried out under FIA supervision. Any parts changed may only be replaced by parts homologated in accordance with Appendix 4 of the F1 Sporting Regulations.

ARTICLE 6: FUEL SYSTEM

6.1 Fuel tanks

- 6.1.1 The fuel tank must be a single rubber bladder conforming to or exceeding the specifications of FIA Standard FT5-1999, the fitting of foam within the tank however is not mandatory. A list of approved materials may be found in Technical List No.1 (Fuel tank materials homologated on the basis of FT3-1999, FT3.5-1999 and FT5-1999) on the FIA website.
- 6.1.2 When viewed in lateral projection, all the fuel stored on board the car must be situated between the forward-most of the two vertical planes referred to in Article 5.3.7 and 50mm forward of the line a-b-c in Drawing 2.
- Furthermore, no fuel can be stored more than 300mm forward of point c) in Drawing 2. However, a maximum of 0.25 litres of fuel may be kept outside the survival cell, but only that which is necessary for the normal running of the engine.
- 6.1.3 Fuel must not be stored more than 400mm from the longitudinal axis of the car.
- 6.1.4 No rubber bladders shall be used more than 5 years after the date of manufacture.

6.2 Fittings and piping

- 6.2.1 All apertures in the fuel tank must be closed by hatches or fittings which are secured to metallic or composite bolt rings bonded to the inside of the bladder. The total area of any such hatches or fittings which are in contact with the fuel may not exceed 30000mm².
- Bolt hole edges must be no less than 5mm from the edge of the bolt ring, hatch or fitting.
- 6.2.2 All fuel lines between the fuel tank and the engine must have a self-sealing breakaway valve. This valve must separate at less than 50% of the load required to break the fuel line fitting or to pull it out of the fuel tank.
- 6.2.3 No lines containing fuel may pass through the cockpit.
- 6.2.4 All lines must be fitted in such a way that any leakage cannot result in the accumulation of fuel in the cockpit.
- 6.2.5 All components containing fuel at a pressure greater than 10bar must be located outside the fuel tank.

6.3 Crushable structure

The fuel tank must be completely surrounded by a crushable structure, which is an integral part of the survival cell and must be able to withstand the loads required by the tests in Articles 18.2.1 and 18.3.

6.4 Fuel tank fillers

Fuel tank fillers must not protrude beyond the bodywork. Any breather pipe connecting the fuel tank to the atmosphere must be designed to avoid liquid leakage when the car is running and its outlet must not be less than 250mm from the cockpit opening.

All fuel tank fillers and breathers must be designed to ensure an efficient locking action which reduces the risk of an accidental opening following a crash impact or incomplete locking after refuelling.

6.5 Refuelling

- 6.5.1 A cover must be fitted over any refuelling connector at all times when the car is running on the track. The cover and its attachments must be sufficiently strong to avoid accidental opening in the event of an accident.
- 6.5.2 No fuel intended for immediate use in a car may be more than ten degrees centigrade below ambient temperature. When assessing compliance, the ambient temperature will be that

recorded by the FIA appointed weather service provider one hour before any practice session or two hours before the race. This information will also be displayed on the timing monitors.

The temperature of fuel intended for use in a car must be measured via an FIA approved and sealed sensor.

- 6.5.3 The use of any device on board the car to decrease the temperature of the fuel is forbidden.

6.6 Fuel draining and sampling

- 6.6.1 Competitors must provide a means of removing all fuel from the car.

- 6.6.2 Competitors must ensure that a 1.0 litre sample of fuel may be taken from the car at any time during the Event.

After a practice session, if a car has not been driven back to the pits under its own power, it will be required to supply the above mentioned sample plus the amount of fuel that would have been consumed to drive back to the pits. The additional amount of fuel will be determined by the FIA.

- 6.6.3 All cars must be fitted with a –2 'Symetrics' male fitting in order to facilitate fuel sampling. If an electric pump on board the car cannot be used to remove the fuel an externally connected one may be used provided it is evident that a representative fuel sample is being taken. If an external pump is used it must be possible to connect the FIA sampling hose to it and any hose between the car and pump must be -3 in diameter and not exceed 2m in length. Details of the fuel sampling hose may be found in the Appendix to the Technical and Sporting Regulations.

- 6.6.4 The sampling procedure must not necessitate starting the engine or the removal of bodywork (other than the nosebox assembly and the cover over any refuelling connector).

ARTICLE 7: OIL AND COOLANT SYSTEMS AND CHARGE AIR COOLING

7.1 Location of oil tanks

All oil storage tanks must be situated between the front wheel axis and the rearmost gearbox casing longitudinally, and must be no further than the lateral extremities of the survival cell are from the longitudinal axis of the car.

7.2 Longitudinal location of oil system

No other part of the car containing oil may be situated behind the complete rear wheels.

7.3 Transversal location of oil system

No part of the car containing oil may be more than 800mm from the car centre plane.

7.4 Coolant header tanks

Any header tank used on the car with a water based coolant must be fitted with an FIA approved pressure relief valve which is set to a maximum of 3.75 bar gauge pressure, details of the relief valve may be found in the Appendix to the Technical and Sporting Regulations. If the car is not fitted with a header tank, an alternative position must be approved by the FIA.

7.5 Cooling systems

The cooling systems of the power unit, including that of the air destined for combustion, must not intentionally make use of the latent heat of vaporisation of any fluid with the exception of fuel for the normal purpose of combustion in the engine as described in Article 5.10.3.

7.6 Oil and coolant lines

7.6.1 No lines containing coolant or lubricating oil may pass through the cockpit.

7.6.2 All lines must be fitted in such a way that any leakage cannot result in the accumulation of fluid in the cockpit.

7.6.3 No hydraulic fluid lines may have removable connectors inside the cockpit.

7.7 Main oil tank level measurement

The measurement of the oil level in the main oil tank must be supplied to FIA at all times. The main oil tank is the oil tank directly connected to the engine oil feed at the inlet of the oil pressure pump.

7.8 Oil injection

The use of active control valves between any part of the PU and the engine intake air is forbidden.

7.9 AOT

7.9.1 Only one AOT may be fitted to the car.

7.9.2 The total volume of the AOT and its connections to the engine must not be greater than 2.5l. The transfer of oil between the AOT and the engine must be controlled by a solenoid.

ARTICLE 8: ELECTRICAL SYSTEMS

8.1 Software and electronics inspection

8.1.1 Prior to the start of each season the complete electrical system on the car must be examined and all on board and communications software must be inspected by the FIA Technical Department.

The FIA must be notified of any changes prior to the Event at which such changes are intended to be implemented.

8.1.2 All re-programmable microprocessors must have a mechanism that allows the FIA to accurately identify the software version loaded.

Acceptable solutions to verify the programmed software may be found in the Appendix to the Technical and Sporting Regulations.

8.1.3 All electronic units containing a programmable device, and which are intended for use at an Event, must be presented to the FIA before each Event in order that they can be identified.

8.1.4 All on-car software versions must be registered with the FIA before use.

8.1.5 The FIA must be able to test the operation of any compulsory electronic safety systems at any time during an Event.

8.1.6 Competitors may only run custom software that has been homologated by the FIA for their control applications hosted inside or outside the ECU described in Article 8.2.1.

Details of the homologation process can be found in the Appendix to the Technical and Sporting Regulations.

8.1.7 The number of versions used in any single championship season will be limited as shown in the table below. Figures are given per custom control application.

	2021	2022	2023	2024	2025
ECU Team applications	5	5	5	5	5
ECU PU applications	5	5	5	1	1
ERS & PU-CE Applications	3	5	3	1	1

A version will be deemed to have been used once the car's timing transponder has shown that it has left the pit lane.

Changes made solely for reliability, bug fix, compatibility with standard or other custom applications or changes requested by the FIA will not increase the version counter.

8.2 Control electronics

8.2.1 All components of the power unit, gearbox, clutch and differential, in addition to all associated actuators, must be controlled by an Electronic Control Unit (ECU) which has been manufactured by an FIA designated supplier to a specification determined by the FIA.

The ECU may only be used with FIA approved software and may only be connected to the control system wiring loom, sensors and actuators in a manner specified by the FIA.

Additional information regarding the ECU software versions and setup may be found in the Appendix to the Technical and Sporting Regulations.

8.2.2 All control sensors, actuators and FIA monitoring sensors will be specified and homologated by the FIA. Details of the homologation process may be found in the Appendix to the Technical and Sporting Regulations.

Each and every component of the control system will be sealed and uniquely identified and their identities tracked through their life cycle.

These components and units may not be disassembled or modified in any way and seals and identifiers must remain intact and legible.

8.2.3 The control system wiring loom connectivity must be approved by the FIA.

All wiring looms must be built to ensure that each control sensor and each control actuator connected to the ECU is electrically isolated from logging-only sensors connected to either the ECU or a team data acquisition unit.

In general, there must be no active or passive electronic component in the control loom. Exceptions (e.g. termination resistors) must be approved by the FIA before use.

Additional wiring guidelines may be found in the Appendix to the Technical and Sporting Regulations.

8.2.4 If sensor faults or errors are detected by the driver or by the on-board software, back-up sensors may be used and different settings may be manually or automatically selected. However, any back-up sensor or new setting chosen in this way must not enhance the performance of the car. Any driver default turned on during the start lockout period may not be turned off before the end of that period.

8.2.5 Pneumatic valve pressure may only be controlled via a passive mechanical regulator or from the ECU and its operation will be monitored by the ECU.

8.3 Start systems

8.3.1 Any system, the purpose and/or effect of which is to detect when a race start signal is given, is not permitted.

8.3.2 The ECU will implement a “lockout” period after each race start or pit stop during which a number of power unit and clutch related functions will be frozen or disabled. Details of the strategy may be found in the Appendix to the Technical and Sporting Regulations.

8.4 Data acquisition

8.4.1 To assist scrutineering, the FIA requires unlimited access to the following ECU information before, during and after any track session:

- a. Application parameter configurations.
- b. Logged data and events.
- c. Real-time telemetry data and events.

Throughout the Event, the logging memory and events buffer may only be cleared by an FIA engineer.

The FIA must have the ability to connect to the ECU via a jump battery using an FIA laptop. The teams should make a jump battery available at all times during the Event.

The teams should transfer the real-time telemetry data and events on the FIA network as requested by, and in the format defined by, the FIA.

Prior to the race, the ECU data logger must be configured in such a way that allows logging of data for at least two hours and fifteen minutes without exceeding the size of the logger memory.

8.4.2 Any data acquisition system, telemetry system or associated sensors additional to those provided by the ECU and ADR must be physically separate and electrically isolated from any control electronics with the exception of:

- a. The primary regulated voltage supply.
- b. The car system ground.
- c. Communication links to the ECU, telemetry unit and ADR.

- d. Power supplies, provided they are not used to power any control electronics, control sensors or actuators.
- e. Time synchronisation lines.
- f. Power unit synchronisation lines.
- g. An umbilical loom whose connector will remain disconnected when the car is moving.

No junction box or break-out box may be shared between the ECU system and a team data acquisition system.

The use of any coupling, be it hard wired, magnetic, optical or other such link which allows the transmission of signals will not be considered as adequate isolation in the context of this Article.

8.5 Telemetry

- 8.5.1 All cars must be fitted with a telemetry system which has been manufactured by the FIA designated supplier to a specification determined by the FIA.
- 8.5.2 Telemetry systems must operate at frequencies which have been approved by the FIA.
- 8.5.3 Pit to car telemetry is prohibited.

8.6 Driver controls and displays

- 8.6.1 Any electronic modules used for driver information displays and switch inputs must be supplied by an FIA designated supplier to a specification determined by the FIA and be suitably housed by each team.
- 8.6.2 Any single control device, including but not limited to switch, button, paddle or pedal, used by the driver must be connected to a single analogue or digital input of the ECU.

Exceptions will be considered to handle the following:

- a. A spare clutch paddle sensor.
- b. A spare accelerator pedal sensor.
- c. A separate "kick-down" sensor which indicates that the accelerator pedal has been deliberately depressed past full travel.
- d. Multiplexed shift signals.
- e. A spare brake pressure and pedal sensor.

Any interface between such driver operated devices and the ECU must be approved by the FIA.

- 8.6.3 Any alteration of the driver's controls may only be commanded by direct, deliberate and primary driver actions.

The logged raw signals from the ECU inputs must provide a true representation of the driver's actions.

8.7 Driver radio

Other than authorised connections to the FIA ECU, any voice radio communication system between car and pits must be stand-alone and must not transmit or receive other data. All such communications must be open and accessible to both the FIA and broadcasters.

8.8 Accident data recorders (ADR) and high speed accident cameras

- 8.8.1 The recorder must be fitted and operated:
 - a. In accordance with the instructions of the FIA.
 - b. Symmetrically about the car centre plane and with its top facing upwards.

- c. With each of its 12 edges parallel to an axis of the car.
 - d. Less than 200mm above the reference plane.
 - e. In a position within the cockpit which is readily accessible at all times from within the cockpit without the need to remove plank or floor.
 - f. In order that the entire unit lies between 30% and 50% of the wheelbase of the car.
 - g. Via anti-vibration mountings giving a clearance of 5mm to all other objects.
 - h. With its connectors facing forwards.
 - i. In order that its status light is visible when the driver is seated normally.
 - j. In order that the download connector is easily accessible when the driver is seated normally and without the need to remove bodywork.
- 8.8.2** The recorder must be connected to two external 500g accelerometers which are solidly bolted to the survival cell, on the car centre plane, using four 4mm bolts. One must be as close to the nominal car centre of gravity as practical and the other as far forward as possible inside the survival cell. The forward accelerometer may be mounted to the underside of the top surface provided it is solidly bolted to a structural part of the survival cell.
- 8.8.3** The recorder must be powered from a nominally 12V supply such that its internal battery can be recharged at all times when the car's electronic systems are powered and when the car systems are switched off, but a jump battery or umbilical is connected.
- 8.8.4** An ADR and two accelerometers must be fitted to every car at all times during an Event and at all tests attended by more than one team.
- 8.8.5** Details of the connections to the ADR may be found in the Appendix to the Technical and Sporting Regulations.
- 8.8.6** For the purpose of accident analysis, each car must be fitted with a high speed camera which has been manufactured by the FIA designated supplier to a specification determined by the FIA. This should be fitted to the car during each Event and all tests which are attended by more than one team, teams must use their best endeavours to ensure that it is in working order at all times.

The camera must be fitted in accordance with the instructions of the FIA, details of which may be found in the Appendix to the Technical and Sporting Regulations.

8.9 Track signal information display

All cars must be fitted with red, blue and yellow cockpit lights the purpose of which are to give drivers information concerning track signals or conditions. The lights must be LEDs each with a minimum diameter of 5mm and fitted directly in the driver's normal line of sight.

Details of the light control system, which must be fitted to every car, may be found in the Appendix to the Technical and Sporting Regulations.

8.10 Medical warning system

In order to give rescue crews an immediate indication of accident severity each car must be fitted with a warning light which is connected to the FIA data logger.

The light must face upwards and be recessed into the top of the survival cell no more than 150mm from the car centre plane, no more than 1150mm forward of the plane C-C and as near to the clutch disengagement system, as described in Article 9.4, as is practical.

Details of the light and its control system may be found in the Appendix to the Technical and Sporting Regulations.

8.11 Installation of electrical systems or components

- 8.11.1** Exceptionally, each car may be equipped with a maximum of five test sensor installations, which do not comply with the Technical Regulations, during P1, P2 and P3, provided:
- a. They could not materially affect the outcome any of the impact tests described in Articles 16.2, 16.3 and 16.4.
 - b. They comply with Articles 3.2 and 3.6.1.
 - c. They do not reduce or affect driver visibility.
 - d. They do not obstruct on-board camera views.

Any such test sensor installations do not need to be homologated.

The FIA technical delegate must be notified of any intended test sensor installations prior to the Event at which they are first used.

- 8.11.2** Competitors must be notified of any changes to the installation instructions for any FIA specified systems or components before 1 March of the previous season.

ARTICLE 9: TRANSMISSION SYSTEM

9.1 Transmission types

No transmission system may permit more than two wheels to be driven.

9.2 Clutch control

The following applies only to the main drivetrain clutch or clutches, any clutch used exclusively as part of an ERS is exempt.

9.2.1 Clutch operating devices must be in the form of paddles, which comply with the following principles:

- a. There should be a maximum of two, mounted on the steering wheel for direct access in all circumstances.
- b. They should be of pull-type, opening the clutch when pulling the paddle towards the driver.
- c. Their travel should be in a plane nominally normal to the face of the steering wheel, with a maximum displacement of the driver's contact surfaces of 80mm between end stops.
- d. They should have only a single degree of freedom.
- e. Where two paddles are fitted, they must be a left and right handed pair, identical in function and ergonomics, mounted in a symmetrically opposite manner on either side of the steering wheel centre plane. For the avoidance of doubt, they must have the same mechanical travel characteristics and be mapped identically.

No interaction between them or the associated FIA ECU inputs will be permitted and, furthermore, competitors must be able to demonstrate beyond any doubt that each of the paddles may only be operated with only one hand.

- f. To ensure that the signals used by the FIA ECU are representative of the driver's actions, each competitor is required to demonstrate that the paddle percentage calculated by the ECU does not deviate by more than +/-5% from the physical position of the operating device measured as a percentage over its entire usable range.

In that context, the physical position of the paddle will be measured at the location operated by the fingers.

9.2.2 Designs which allow specific points along the travel range of the clutch operating device to be identified by the driver or assist him to hold a position are not permitted.

In order to prevent interaction between the clutch paddles and other driver control devices, at least one of the following arrangements must be respected:

- a. When pulled to its maximum travel position, any clutch paddle should not reach further than the driver's contact surfaces of any other paddle, lever or switch in any of their positions.
- b. The outboard 60% portion of any clutch paddle, measured from its mounting point to its outer edge by the driver's contact surface, should be a minimum of 50mm away over its entire travel range from any other paddle, lever or switch.
- c. A clutch paddle should be separated from any adjacent paddle, lever or switch by a physical stop preventing any practical interaction between them by the driver. Such stop should be sized and shaped so that it cannot be used as a reference point during paddle operation.

In addition, other parts of the steering wheel or chassis should not be practically usable as reference points for the driver to identify or hold a specific position.

- 9.2.3 The minimum and maximum travel positions of the clutch operating device must correspond to the clutch fully engaged normal rest position and fully disengaged (incapable of transmitting any useable torque) positions respectively.
- 9.2.4 Designs or systems which in addition to typical inherent hydraulic and mechanical properties are designed to, or have the effect of, adjusting or otherwise influencing the amount, or rate, of engagement being demanded by the FIA ECU, are not permitted.
- 9.2.5 The amount by which the clutch is engaged must be controlled solely and directly by the driver with the exception of :
- a. Stall prevention
 - b. Gearshifts
 - c. Bite point finder where brake pressure, wheel speed and driver clutch demand safeguards are used.
 - d. De-clutch protections
 - e. Drivetrain protection on the track outside of any start lockout period or immediately following stall prevention activation only
 - f. Test signals enabled only when the car is connected to the garage system.

When commanded by the driver, the amount of clutch engagement will be expressed in the FIA ECU as torque at the rear axle by applying a gain of 4500Nm / 90% to the clutch paddle position between 5% and 95%.

In that case the clutch torque controller implemented in the FIA ECU must be used. Except for the first 70ms following the initial step in clutch torque demand during a launch, the control error, calculated using the power unit output shaft torque sensor, must be contained in a band of +/-150Nm when converted at the rear axle.

- 9.2.6 When the clutch operating device is released from its maximum travel position it must return to its resting position within 50ms.
- The maximum delay allowed, computed from the respective signals as recorded by the ADR or ECU, between the clutch driver control input signal and the corresponding output demand being achieved is 50ms.
- 9.2.7 Any device or system which notifies the driver of the amount of clutch slip or engagement is not permitted.

9.3 Traction control

No car may be equipped with a system or device which is capable of preventing the driven wheels from spinning under power or of compensating for excessive torque demand by the driver.

Any device or system which notifies the driver of the onset of wheel spin is not permitted.

9.4 Clutch disengagement

All cars must be fitted with a means of disengaging the clutch for a minimum of fifteen minutes in the event of the car coming to rest with the engine stopped. This system must be in working order throughout the Event even if the main hydraulic, pneumatic or electrical systems on the car have failed. This system must also disconnect any ERS system fitted to the car.

In order that the driver or a marshal may activate the system in less than five seconds, the switch or button which operates it must :

- a. Face upwards and be recessed into the top of the survival cell no more than 150mm from the car centre plane.
- b. Be designed in order that a marshal is unable to accidentally re-engage the clutch.

- c. Be no more than 1150mm forward of the plane C-C.
- d. Be marked with a letter "N" in red at least 40mm tall, with a line thickness of at least 4mm, inside a white circle of at least 50mm diameter with a red edge with a line thickness of at least 2mm.

9.5 Gearboxes

9.5.1 A gearbox is defined as all the parts in the drive line which transfer torque from the power unit output shaft, as described in Article 5.3.2, to the drive shafts (the drive shafts being defined as those components which transfer drive torque from the sprung mass to the unsprung mass). It includes all components whose primary purpose is for the transmission of power or mechanical selection of gears, bearings associated with these components and the casing in which they are housed.

9.5.2 In this context the following parts are not considered part of the gearbox and may be changed without incurring a penalty under the F1 Sporting Regulations. If changing any of these parts involves breaking an FIA applied seal this may be done but must be carried out under FIA supervision :

- a. The clutch assembly and the power unit output shaft, provided this is located prior to any mechanical speed reduction from the engine.
- b. The clutch actuator and clutch release bearing(s).
- c. Inboard driveshaft joints and seals but not their housing if that housing is integral with the gearbox output shaft and therefore part of the sprung mass.
- d. The hydraulic system prior to the point at which it produces direct mechanical movement of the gear selection mechanism by means of hydraulic actuator(s).
- e. Oil, oil pumps, oil filters, oil seals, oil coolers and any associated hoses or pipes.
- f. Electrical sensors, actuators, servo valves and wiring.
- g. Any parts associated with the suspension or functioning of the sprung suspension that are attached to the gearbox casing.
- h. The rear impact structure provided it can be separated from any gearbox casing.
- i. Any other component mounted to the casing whose primary purpose is unconnected with the transmission of power or selection of gears.

9.6 Gear ratios

9.6.1 The number of forward gear ratios must be 8.

9.6.2 Each competitor must nominate the forward gear ratios (calculated from engine crankshaft to drive shafts) to be employed within their gearbox. These nominations must be declared to the FIA technical delegate at or before the first Event of the Championship.

9.6.3 No forward gear ratio pair may be :

- a. Less than 12mm wide when measured across the gear tooth at the root diameter or any point 1mm above or below the root diameter. Above this area each side of the gear teeth may be chamfered by a maximum of 10°. In addition, a chamfer or radius not exceeding 2.0mm may be applied to the sides and the tip of the teeth.
- b. Less than 85mm between centres.
- c. Less than 600g in weight (excluding any integral shaft or collar). If an integral shaft or collar is to be excluded the mass of this may be shown by calculation assuming the gear to be 12mm wide and the shaft geometry to be the same as that where slide on gears are used.

9.6.4 Gear ratios must be made from steel.

9.6.5 Continuously variable transmission systems are not permitted to transmit the power of the power unit defined in Article 5.1.

9.7 Reverse gear

All cars must be able to be driven in reverse by the driver at any time during the Event.

9.8 Gear changing

9.8.1 Automatic gear changes are considered a driver aid and are therefore not permitted.

For the purposes of gear changing, the clutch and power unit torque need not be under the control of the driver.

9.8.2 Gear changing is restricted during the following periods :

One gear change is permitted after the race has started and before the car speed has reached 80km/h, provided every gear fitted to the car is capable of achieving at least 80km/h at 15,000rpm.

9.8.3 The minimum possible gear the driver is able to select must remain fixed whilst the car is moving.

Each individual gear change must be separately initiated by the driver and, within the mechanical constraints of the gearbox; the requested gear must be engaged immediately unless over-rev protection is used to reject the gear shift request. Once a gear change request has been accepted no further requests may be accepted until the first gear change has been completed.

Multiple gear changes may only be made under Article 5.21 or when a shift to gearbox neutral is made following a request from the driver.

If an over-rev protection strategy is used this may only prevent engagement of the target gear, it must not induce a delay greater than 50ms. If a gear change is refused in this way, engagement may only follow a new and separate request made by the driver.

Any de-bounce time used to condition driver gear change requests must be fixed.

9.8.4 The maximum permitted duration for down changes and up changes is 300ms and 200ms respectively. The maximum permitted delay for the latter is 80ms from the time of the driver request to the original gear being disengaged.

The duration of a gear change is defined as the time from the request being made to the point at which all gear change processes are terminated. If for any reason the gear change cannot be completed in that time the car must be left in neutral or the original gear.

9.8.5 Distance channel or track position is not considered an acceptable input to gearbox control.

9.9 Torque transfer systems

9.9.1 Any system or device the design of which is capable of transferring or diverting torque from a slower to a faster rotating wheel is not permitted.

9.9.2 Any device which is capable of transferring torque between the principal axes of rotation of the two front wheels is prohibited.

ARTICLE 10: SUSPENSION AND STEERING SYSTEMS

10.1 Sprung suspension

- 10.1.1 Cars must be fitted with sprung suspension.
- 10.1.2 Any suspension system fitted to the front wheels must be so arranged that its response results only from changes in load applied to the front wheels.
- 10.1.3 Any suspension system fitted to the rear wheels must be so arranged that its response results only from changes in load applied to the rear wheels.

10.2 Suspension geometry

- 10.2.1 With the steering wheel fixed, the position of each wheel centre and the orientation of its rotation axis must be completely and uniquely defined by a function of its principally vertical suspension travel, save only for the effects of reasonable compliance which does not intentionally provide further degrees of freedom.
- 10.2.2 Any powered device which is capable of altering the configuration or affecting the performance of any part of any suspension system is forbidden.
- 10.2.3 No adjustment may be made to any suspension system while the car is in motion.

10.3 Suspension members

- 10.3.1 With the exception of minimal local changes of section for the passage of hydraulic brake lines, electrical wiring and wheel tethers or the attachment of flexures, rod ends and spherical bearings, the cross-sections of each member of every suspension component, when taken normal to a straight line between the inner and outer attachment points, must :
 - a. Intersect the straight line between the inner and outer attachment points, with the exception of front suspension elements for the sole purpose of ensuring minimum clearance with the wheel rim at full steering lock.
 - b. Have a major axis no greater than 100mm.
 - c. Have an aspect ratio no greater than 3.5:1.
 - d. Have no dimension which exceeds 100mm.

The major axis will be defined as the largest axis of symmetry of any such cross-section. The length of the intersection of this axis with the cross-section must not be less than 95% of the maximum dimension of the section.

- 10.3.2 Suspension members having shared attachment points will be considered by a virtual dissection into discrete members.
- 10.3.3 No major axis of a cross section of a suspension member, taken normal to a straight line between the inner and outer attachment points, when assessed in accordance with Article 10.3.1, may subtend an angle greater than 10° to the reference plane with the car set to the nominal design ride height.

Furthermore, the angle between the normal to any point of the surface of a suspension member and a plane normal to the line joining the inner and outer attachments of that suspension member must not exceed 15deg. Legitimate exceptions to this constraint will be accepted close to the inner and outer attachment points, or close to the junction between suspension members that share an attachment.

- 10.3.4 Non-structural parts of suspension members are considered bodywork.
- 10.3.5 There may be no more than six suspension members connecting each suspension upright to the fully sprung part of the car.

Redundant suspension members are not permitted.

- 10.3.6** In order to help prevent a wheel becoming separated in the event of all suspension members connecting it to the car failing, flexible tethers each with a cross sectional area greater than 110mm² must be fitted. The sole purpose of the tethers is to prevent a wheel becoming separated from the car, they should perform no other function.

Each wheel must be fitted with three tethers each of which comply with FIA standard 8864-2013 and each of which has a minimum energy absorption of 7kJ. No suspension member may contain more than two tethers.

Each tether must have its own separate attachments at both ends, which :

- a. Are able to withstand a tensile force of 70kN in any direction within a cone of 45° (included angle) measured from the load line of the relevant suspension member.
- b. Are able to accommodate tether end fittings with a minimum inside diameter of 15mm.
- c. Do not share a common fastener and are designed such that the failure of one attachment point will not lead to the direct failure of an adjacent attachment point.
Furthermore, at least two of the three tethers must have attachment points which:
- d. On the survival cell or gearbox are separated by at least 100mm measured between the centres of the two attachment points.
- e. On each wheel/upright assembly are separated by at least 90° radially with respect to the axis of the wheel and 100mm measured between the centres of the two attachment points.

Each tether must exceed 450mm in length and must utilise end fittings which result in a tether bend radius greater than 7.5mm.

Each team must supply detailed geometries which clearly show that any two of the three tethers will independently prevent a wheel from making contact with a driver's head during an accident, assuming 7kJ energy absorption in each tether.

- 10.3.7** Once the suspension members are fully defined to satisfy Articles 10.3.1 to 10.3.6, it is permissible to apply any geometry to the outside of the suspension members, provided that:
- a. It is contained within either of the volumes defined by Article 11.4.1 (and outboard of a plane that lies 5mm inboard of the inboard plane of the wheel rim) or Article 11.5 with the steered wheels in the straight-ahead position.
 - b. It is rigid and rigidly secured to the suspension members (rigidly secured means not having any degree of freedom), with the exception of front suspension elements where minimal flexible parts are allowed for the sole purpose of ensuring minimum clearance with the wheel rim at full steering lock.

10.4 Steering

- 10.4.1** Any steering system which permits the re-alignment of more than two wheels is not permitted.
- 10.4.2** The re-alignment of the steered wheels must be uniquely defined by driver input to a single steering wheel permitted to have only one degree of freedom, which must be rotational, and the relationship between the angle of each steered wheel to the angle of the steering wheel must be a strictly monotonic function.
- 10.4.3** Power assisted steering systems may not be electronically controlled or electrically powered. No such system may carry out any function other than reduce the physical effort required to steer the car.
- 10.4.4** No part of the steering wheel or column, nor any part fitted to them, may be closer to the driver than a plane formed by the entire rear edge of the steering wheel rim. All parts fixed to the steering wheel must be fitted in such a way as to minimise the risk of injury in the event of a driver's head making contact with any part of the wheel assembly.

10.4.5 The steering wheel, steering column and steering rack assembly must pass an impact test, details of the test procedure may be found in Article 16.5.

10.5 Suspension Uprights

10.5.1 The suspension uprights may only be made from UNS A92014, UNS A92618, UNS A97075 or EN/AA 7022 aluminium alloys.

10.5.2 The loads from the suspension members and wheel bearings must individually and entirely be carried by the suspension upright. Exceptionally up to three suspension members may be connected together by titanium, aluminium alloy or steel components before their load is passed into the upright.

10.5.3 Suspension uprights may not protrude beyond:

- a. A vertical plane parallel to the inner face of the wheel rim and displaced from it by 120mm toward the car centre plane.
- b. A radius of 180mm from the centre of the wheel when viewed from the side.

The above measurements will be made with the wheel held in a vertical position.

ARTICLE 11: BRAKE SYSTEM

11.1 Brake circuits and pressure distribution

11.1.1 With the exception of a power unit, all cars must be equipped with only one brake system. This system must comprise solely of two separate hydraulic circuits operated by one pedal, one circuit operating on the two front wheels and the other on the two rear wheels. This system must be designed so that if a failure occurs in one circuit the pedal will still operate the brakes in the other.

The diameters of the master cylinders acting on the two rear wheels and the two front wheels must be within 2mm of each other and have the same available travel. The same principle must be applied in multi-stage master cylinder designs.

11.1.2 The brake system must be designed in order that the force exerted on the brake pads within each circuit are the same at all times.

11.1.3 Any powered device, other than the system referred to in Article 11.9, which is capable of altering the configuration or affecting the performance of any part of the brake system is forbidden.

11.1.4 Any change to, or modulation of, the brake system, other than any movement of the minimal flexible parts described in Article 11.4 to 11.6, whilst the car is on the track must be made by the driver's direct physical input or by the system referred to in Article 11.9, and may not be pre-set.

11.2 Brake calipers

11.2.1 All brake calipers must be made from aluminium materials with a modulus of elasticity no greater than 80Gpa.

11.2.2 No more than two attachments may be used to secure each brake caliper to the car.

11.2.3 No more than one caliper, with a maximum of six pistons, is permitted on each wheel.

11.2.4 The section of each caliper piston must be circular.

11.3 Brake discs and pads

11.3.1 No more than one brake disc is permitted on each wheel which must have the same rotational velocity as the wheel it is connected to.

11.3.2 All discs must have a maximum thickness of 32mm and a maximum outside diameter of 278mm.

11.3.3 No more than two brake pads are permitted on each wheel.

11.4 Front air ducts

All measurements in this Article will be made with the wheel held in a vertical and straight-ahead position, and furthermore any criteria of visibility will assume that the entire sprung part of the car, the suspension and the tyres have been removed.

11.4.1 Air ducts around the front brakes will be considered part of the braking system. These air ducts:

- a. Must lie entirely outboard of a plane parallel to the inner face of the wheel rim and displaced from it by 120mm toward the car centre plane.
- b. Must not protrude beyond a radius of 180mm from the centre of the wheel, when viewed from the side.

For any part of the air duct which is in contact with the external air stream and between 120mm and 5mm inboard of a plane parallel with the inner face of the wheel rim, the following conditions must be satisfied:

- c. Any intersection with a vertical lateral or horizontal plane must produce a single tangent-continuous curve. Furthermore, this tangent-continuous curve must be fully visible when viewed from the car centre plane.
- d. The local radius of curvature must be greater than 20mm. In order to fulfil this criterion, it should be possible to apply a tangent sphere of radius 20mm to any point of these surfaces (and on both sides), without intersecting any other part of these surfaces.
- e. Any intersection with a vertical longitudinal plane must produce a single closed section

All parts of the air duct more than 5mm inboard of a plane parallel to the inner face of the wheel rim must fit entirely between two planes which are parallel to the reference plane and separated by 180mm.

11.4.2 Once the geometry has been defined in accordance to Article 11.4.1, the following apertures may be added :

- a. A single aperture may be applied to the part of the air duct which is in contact with the external air stream and between 120mm and 5mm inboard of a plane parallel with the inner face of the wheel rim. This aperture must be:
 - i. Fully visible from the front of the car and may not be taller than 180mm when measured normal to the reference plane.
 - ii. Constructed such that no point on its periphery is more than 50mm from any other such point when measured normal to plane A-A.
 - iii. Entirely forward of the front wheel centre line.
- b. Apertures where suspension legs, uprights or mounting brackets intersect the surface of the air duct must be minimal in size in order to permit the full vertical travel and steer of the suspension system. Furthermore, they must be internally sealed in such way so as to prevent any air flow from another aperture.

For clarity, apertures as referred to in this Article are considered to be mathematical surfaces that are coincident with the surfaces constructed in accordance with Article 11.4.1 and bound by their periphery. Any criterion of visibility in this article will consider these surfaces to be non-transparent.

11.4.3 No air flow may pass through a circular section 105mm in diameter with its centre lying along the axis and its plane coinciding with the inboard face of the wheel fastener described in Article 12.8.2.

11.5 Rear air ducts

Air ducts around the rear brakes will be considered part of the braking system and shall not protrude beyond :

- a. A plane parallel to the ground situated at a distance of 160mm above the horizontal centre line of the wheel.
- b. A plane parallel to the ground situated at a distance of 160mm below the horizontal centre line of the wheel.
- c. In the forward direction, a radius of 330mm from the centre of the wheel or in the rearward direction a radius of 180mm from the centre of the wheel, when viewed from the side.

Furthermore, regions of the air duct above a horizontal plane 50mm below the centre line of the wheel, must not protrude beyond a vertical plane parallel to the inner face of the wheel rim and displaced from it by 120mm toward the car centre plane. Regions of the air duct below this horizontal plane must not protrude beyond a vertical plane parallel in the inner face of the wheel and displaced from it by 80mm towards the car centre plane

All measurements will be made with the wheel held in a vertical position.

11.6 Common rules for front and rear air ducts

Air ducts for both the front and the rear brakes must also satisfy the following requirements :

- a. They may not rotate with the wheels nor may they, or any of their mountings, protrude axially beyond the outer face of the wheel fastener.
- b. No part of the car, other than those specifically defined in Articles 12.8.1 and 12.8.2, may obscure any part of the wheel when viewed from the outside of the car towards the car centre plane along the axis of the wheel.

Furthermore, with the exception of minimal flexible parts for the sole purpose of allowing an aerodynamic seal to be maintained to the suspension members and wheels, the air ducts must:

- c. Be rigid and rigidly secured to the suspension uprights described in Article 10.5 (rigidly secured means not having any degree of freedom).
- d. Not be rigidly secured to the suspension members.

11.7 Brake pressure modulation

11.7.1 No braking system may be designed to prevent wheels from locking when the driver applies pressure to the brake pedal.

11.7.2 No braking system may be designed to increase the pressure in the brake calipers above that achieved by the driver applying pressure to the pedal under all conditions.

11.8 Liquid cooling

Liquid cooling of the brakes is forbidden.

11.9 Rear brake control system

The pressure in the rear braking circuit may be provided by a powered control system provided that:

- a. The driver brake pedal is connected to a hydraulic master cylinder that generates a pressure source that can be applied to the rear braking circuit if the powered system is disabled.
- b. The powered system is controlled by the control electronics described in Article 8.2.

ARTICLE 12 : WHEELS AND TYRES

12.1 Location

Wheels must be external to the bodywork in plan view, with the rear aerodynamic device removed.

12.2 Number of wheels

The number of wheels is fixed at four.

12.3 Wheel material

Wheels must be made from AZ70 or AZ80 magnesium alloys.

12.4 Wheel dimensions

12.4.1 Complete wheel width must lie between 370mm and 385mm when fitted to the front of the car and between 455mm and 470 mm when fitted to the rear.

12.4.2 Complete wheel diameter must not exceed 670mm when fitted with dry-weather tyres or 680mm when fitted with wet weather tyres.

12.4.3 Complete wheel width and diameter will be measured horizontally at axle height, with the wheel held in a vertical position and when fitted with new tyres inflated to 1.4 bar.

12.4.4 Wheel dimensions and geometry must comply with the following specifications :

- a. The minimum wheel thickness is 2.5mm.
- b. The minimum bead thickness is 4.0mm (measured from hump to outer edge of the lip).
- c. The ETRTO standard bead profile is prescribed.
- d. The tyre mounting widths are 13.7" (348.0mm +/-0.5mm) front; 16.9" (429.3mm +/-0.5mm) rear.
- e. The wheel lip thickness is 9mm (+/-1mm).
- f. The outer lip diameter is 358mm (+/-1mm).
- g. A lip recess of maximum 1.0mm depth between a radius of 165mm and a radius of 173mm from wheel axis is permitted (for wheel branding, logo, part number, etc.).
- h. With the exception of the wheel lip, only a single turned profile with a maximum thickness of 8mm is allowed radially outboard of the exclusion zones specified in Article 12.4.5.
- i. The design of the wheel must meet the general requirements of the tyre supplier for the mounting and dismounting of tyres including allowance for sensors and valves.
- j. The wheel design cannot be handed between left and right designs.

12.4.5 No wheel material is permitted in the following exclusion zones :

- a. A concentric cylinder of diameter 305mm and length 115mm positioned with its inner face lying in the same plane as the inboard face of the front wheel.
- b. A concentric cylinder of diameter 305mm and length 25mm positioned with its outer face lying in the same plane as the outboard face of the front wheel.
- c. A concentric cylinder of diameter 305mm and length 100mm positioned with its inner face lying in the same plane as the inboard face of the rear wheel.
- d. A concentric cylinder of diameter 305mm and length 30mm positioned with its outer face lying in the same plane as the outboard face of the rear wheel.

- 12.4.6 When viewed perpendicular to the plane formed by the outer face of the wheel and between the diameters of 120mm and 270mm the wheel may have an area of no greater than 24,000mm².

12.5 Supply of tyres

- 12.5.1 All tyres must be used as supplied by the manufacturer, any modification or treatment such as cutting, grooving, the application of solvents or softeners is prohibited. This applies to dry, intermediate and wet-weather tyres.
- 12.5.2 If, in the opinion of the appointed tyre supplier and FIA technical delegate, the nominated tyre specification proves to be technically unsuitable, the stewards may authorise the use of additional tyres to a different specification.
- 12.5.3 If, in the interests of maintaining current levels of circuit safety, the FIA deems it necessary to reduce tyre grip, it shall introduce such rules as the tyre supplier may advise or, in the absence of advice which achieves the FIA's objectives, specify the maximum permissible contact areas for front and rear tyres.

12.6 Specification of tyres

- 12.6.1 Tyre specifications will be determined by the tyre supplier, in agreement with the FIA, no later than 1 November of the previous season for the construction and 1 December for the range of compounds to be used during the Championship season. Once determined in this way, the specification of the tyres will not be changed without the agreement of at least 70% of the competing teams.

Notwithstanding the above, the FIA may decide to change the specification during the Championship season for safety reasons without notice or delay.

12.7 Treatment of tyres

- 12.7.1 Tyres may only be inflated with air or nitrogen.
- 12.7.2 Any process the intent of which is to reduce the amount of moisture in the tyre and/or in its inflation gas is forbidden.
- 12.7.3 The only permitted type of tyre heating devices are blankets which use resistive heating elements. The heating elements may only act upon the outer tyre surface.

12.8 Wheel assembly

- 12.8.1 The only parts which may be physically attached to the wheel in addition to the tyre are surface treatments for appearance and protection, valves for filling and discharging the tyre, wheel fasteners, balance weights, drive pegs, tyre pressure and temperature monitoring devices and spacers on the inboard mounting face of identical specification on all wheels for the same axle.
- 12.8.2 The wheel must be attached to the car with a single fastener. The outer diameter of the fastener must not exceed 105mm and the axial length must not exceed 75mm. The wheel fastener may not attach or mount any part to the car except the wheel assembly described in Article 12.8.1.
- 12.8.3 A complete wheel must contain a single fixed internal gas volume. No valves, bleeds or permeable membranes are permitted other than to inflate or deflate the tyre whilst the car is stationary.
- 12.8.4 Devices which are used to fit or remove wheel fasteners may only be powered by compressed air or nitrogen.

Any sensor systems may only act passively.

ARTICLE 13 : COCKPIT

13.1 Cockpit opening

13.1.1 In order to ensure that the opening giving access to the cockpit is of adequate size, the template shown in Drawing 2 will be inserted into the survival cell and bodywork.

During this test the secondary roll structure, steering wheel, steering column, seat and all padding required by Articles 14.6.1-6 (including fixings), may be removed and the template must be held horizontal so its lower face is parallel to the reference plane and lowered vertically from above the car until its lower face is 525mm above the reference plane.

13.1.2 The forward extremity of the cockpit opening, even if structural and part of the survival cell, must be at least 50mm in front of the steering wheel.

13.1.3 The driver must be able to enter and get out of the cockpit without it being necessary to open a door or remove any part of the car other than the steering wheel. When seated normally, the driver must be facing forwards and the rearmost part of his crash helmet may be no more than 125mm forward of the plane C-C.

13.1.4 From his normal seating position, with all seat belts fastened and whilst wearing his usual driving equipment, the driver must be able to remove the steering wheel and get out of the car within 7 seconds and then replace the steering wheel in a total of 12 seconds.

For this test, the position of the steered wheels will be determined by the FIA technical delegate and after the steering wheel has been replaced steering control must be maintained.

13.2 Steering wheel

13.2.1 The steering wheel must be fitted with a quick release mechanism operated by pulling a concentric flange installed on the steering column behind the wheel.

13.2.2 The steering wheel must be positioned so as it intersects the helmet free volume at all angular positions (details of this volume may be found in the Appendix to the Technical and Sporting Regulations).

13.3 Internal cross section

13.3.1 A free vertical cross section, which allows the outer template shown in Drawing 3 to be passed vertically through the cockpit to a point 100mm behind the face of the rearmost pedal when in the inoperative position, must be maintained over its entire length.

The only things which may encroach on this area are the steering wheel and any padding that is required by Article 14.6.7.

13.3.2 A free vertical cross section, which allows the inner template shown in Drawing 3 to be passed vertically through the cockpit to a point 100mm behind the face of rearmost pedal when in the inoperative position, must be maintained over its entire length.

The only thing which may encroach on this area is the steering wheel.

13.3.3 The driver, seated normally with his seat belts fastened and with the steering wheel removed must be able to raise both legs together so that his knees are past the plane of the steering wheel in the rearward direction. This action must not be prevented by any part of the car.

13.4 Position of the driver's feet

The face of the foremost pedal, when in the inoperative position, must be situated no less than 300mm rearward of the survival cell bulkhead and rearward of the front wheel centre line.

ARTICLE 14 : SAFETY EQUIPMENT

14.1 Fire extinguishers

- 14.1.1 All cars must be fitted with a fire extinguishing system which will discharge into the cockpit and into the engine compartment.
- 14.1.2 Any extinguishant listed in the Appendix to the Technical and Sporting Regulations is permitted.
- 14.1.3 The quantity of extinguishant may vary according to the type of extinguishant used, a list of quantities may be found in the Appendix to the Technical and Sporting Regulations.
- 14.1.4 When operated, the fire extinguishing system must discharge 95% of its contents at a constant pressure in no less than 10 seconds and no more than 30 seconds.
If more than one container with extinguishant is fitted, they must be released simultaneously.
- 14.1.5 Each pressure vessel must be equipped with a means of checking its pressure which may vary according to the type of extinguishant used. A list of pressures may be found in the Appendix to the Technical and Sporting Regulations.
- 14.1.6 The following information must be visible on each container with extinguishant :
- Type of extinguishant ;
 - Weight or volume of the extinguishant ;
 - Date the container must be checked which must be no more than two years after the date of filling.
- 14.1.7 All parts of the extinguishing system must be situated within the survival cell and all extinguishing equipment must withstand fire.
- 14.1.8 Any triggering system having its own source of energy is permitted, provided it is possible to operate all extinguishers should the main electrical circuits of the car fail.
The driver must be able to trigger the extinguishing system manually when seated normally with his safety belts fastened and the steering wheel in place.
Furthermore, a means of triggering from the outside must be combined with the circuit breaker switches described in Article 14.2.1. They must be marked with a letter "E" in red at least 80mm tall, with a line thickness of at least 8mm, inside a white circle of at least 100mm diameter with a red edge with a line thickness of at least 4mm.
- 14.1.9 The system must work in any position, even when the car is inverted.
- 14.1.10 All extinguisher nozzles must be suitable for the extinguishant and be installed in such a way that they are not directly pointed at the driver.

14.2 Master switch

- 14.2.1 The driver, when seated normally with the safety belts fastened and the steering wheel in place, must be able to cut off the electrical circuits to the ignition, all fuel pumps and the rear lights by means of a spark proof circuit breaker switch.
This switch must be located on the dashboard and must be clearly marked by a symbol showing a red spark in a white edged blue triangle.
- 14.2.2 There must also be two exterior horizontal handles which are capable of being operated from a distance by a hook. These handles must be situated at the base of the main roll over structure on both sides of the car and have the same function as the switch described in Article 14.2.1.

14.3 Rear view mirrors

- 14.3.1 All cars must have two mirrors positioned symmetrically about the car's centre plane and mounted so that the driver has visibility to the rear and both sides of the car: mirrors must

remain immobile in relation to the sprung part of the car. Mirrors should be virtually removed for all legality aspects of Article 3 to be satisfied.

A mirror is defined to be the assembly of the following components:

- a. one reflective surface
- b. its housing
- c. mountings which connect the housing to the sprung part of the car.

14.3.2 The reflective surface of each mirror must be a rectangle which is 150mm wide and 50mm high (+2mm/-0mm for both dimensions), with a radius no greater than 10mm applied to each corner.

The reflective surface must be contained within the housing described in the article 14.3.3.

Non-planar reflective surfaces are permitted provided that they can project onto a rectangle of the dimensions specified in this Article.

14.3.3 The housing must be contained within a volume that has:

- a. Upper and lower faces parallel to the reference plane and separated by 80mm
- b. Inner and outer faces parallel to the car centre plane and separated by 160mm
- c. A rear face normal to the reference plane, at an angle of between 60° and 70° to the car centre plane with its outer edge rearwards of its inner edge
- d. A front face parallel to and 75mm forward the rear face when measured in the direction of the car centre line

The lower rear inboard vertex of this volume must lie between 605mm and 730mm forward of plane C-C, between 420mm and 470mm from the car centre plane and between 600mm and 640mm above the reference plane.

No part of the housing or its mountings may obstruct the driver's rearward vision.

14.3.4 There must be no more than two mountings connecting the mirror housing to the bodywork.

- a. A maximum of one mounting may connect the mirror housing to the survival cell. Such a mirror mounting must:
 - i. Lie between two vertical lateral planes, located at the forward and rearward extremities of the inboard face of the volume defined in the article 14.3.3
 - ii. Lie between two horizontal planes, one 550mm above the reference plane, and one parallel to and offset upward by 25mm from the lower face of the volume defined in the article 14.3.3
 - iii. Lie inboard of the inboard face of the volume defined in 14.3.3
 - iv. Form no more than a single section when intersected by any longitudinal vertical or horizontal plane
- b. Any other mirror mounting must lie in its entirety between two vertical longitudinal planes which pass through the innermost and outermost point of the volume defined in the article 14.3.3, and when viewed from above must not protrude more forward than the volume defined in the article 14.3.3 or more than 50mm rearward than the diagonal line defined in Article 3.5.5 (d). Furthermore, any intersection of each such mirror mounting with a vertical lateral plane must:
 - i. Form a single section
 - ii. Be no more than 50mm high or 10mm wide
 - iii. Lie between 550mm above the reference plane and a horizontal plane that passes through the lower face of the volume defined in 14.3.3

14.3.5 Teams will be required on request to supply the FIA with CAD data with regard to the visibility of their mirror arrangement, and the FIA will retain the right to modify the dimensions in

Article 14.3 should it become apparent that the mirror position does not meet the safety requirements.

14.4 Safety belts

It is mandatory to wear two shoulder straps, one abdominal strap and two straps between the legs. These straps must be securely fixed to the car and must comply with FIA standard 8853-2016.

14.5 Rear lights

All cars must have three rear lights in working order throughout the Event which :

- a. Have been supplied by FIA designated manufacturers.
- b. Are clearly visible from the rear.
- c. Can be switched on by the driver when seated normally in the car.

The first such light must:

- d. Face rearwards at 90° to the car centre plane and the reference plane.
- e. Be mounted nominally on the car centre plane.
- f. Be mounted 300mm (+/-5mm) above the reference plane.
- g. Be no less than 595mm behind the rear wheel centre line measured parallel to the reference plane.
- h. Have a nominal dimension of 118mm x 90mm when viewed from behind

The two measurements above will be taken to the centre of the rear face of the light unit.

Additionally, two further lights must be fitted, one on each side of the car, within the bodywork defined in Article 3.6.7. Each such light must:

- i. Occupy a nominally rectangular parallelepiped volume of 120mm x 30mm x 5mm and positioned in full compliance with Article 3.6.7
- j. Have its larger faces completely nominally parallel to the car centre plane (+/- 1deg)
- k. Have its face corresponding to the array of LED lights within 10mm and nominally parallel to the diagonal line defined in Article 3.6.7 (d). Furthermore, this face must be entirely visible from behind the car.
- l. Lie in its entirety between 650mm and 870mm above the reference plane
- m. Be fitted inside a housing made entirely of aluminum, in order to facilitate the dissipation of the heat generated by it
- n. Respect the directionality of the lens of the LED elements, which should point at a nominally horizontal direction towards the back

Details about both types of rear light can be found in the Appendix to the Technical and Sporting Regulations.

14.6 Cockpit padding

14.6.1 All cars must be equipped with three areas of padding for the driver's head which :

- a. Are so arranged that they can be removed from the car as one part.
- b. Are located by either of the following two methods:
 - i. Two cylindrical horizontal pegs behind the driver's head that have a minimum diameter of 6mm and a length of engagement into the survival-cell structure of at least 12mm. In addition, two quick release fixings, which are clearly indicated and easily removable without tools, at the front corners. No tape or similar material may be used to cover the forward fixings of the headrest.

or

- ii. Two horizontal pegs behind the driver's head and four quick release fixings, which are clearly indicated and easily removable without tools. Two positioned at the front corners and two positioned between 350mm and 400 mm forward of the plane CC. The fixings between 350mm and 400 mm forward of the plane CC may not be inside the Helmet Free Volume and should be designed to minimize the risk of injury should the driver come in contact with them during an accident. No tape or similar material may be used to cover the fixings of the headrest.
- c. Are made from a material which is suitable for the relevant ambient air temperature, details of approved materials and the temperature bands in which they should be used may be found in the Appendix to the Technical and Sporting Regulations.
- d. Are covered, in all areas where the driver's head is likely to make contact, with two plies of Aramid fibre/epoxy resin composite pre-preg material in plain weave 60gsm fabric with a cured resin content of 50% (+/-5%) by weight.
- e. Are positioned so as to be the first point of contact for the driver's helmet in the event of an impact projecting his head towards them during an accident.

14.6.2 The first area of padding for the driver's head must be positioned behind him and be between 75mm and 90mm thick over an area of at least 40000mm². If necessary, and only for driver comfort, an additional piece of padding no greater than 10mm thick may be attached to this headrest provided it is made from the same material.

14.6.3 Whilst he is seated normally the two further areas of padding for the driver's head must be positioned in an area bounded by two vertical lines and one horizontal line through the front, rear and lower extremities of the driver's helmet (on the car centre plane), and the upper surface of the survival cell.

Each of these must cover an area greater than 35750mm² when viewed from the side of the car and be no less than 95mm thick, this minimum thickness being maintained to the upper edges of the survival cell and over their entire length. The minimum thickness will be assessed perpendicular to the car centre plane but a radius no greater than 10mm may be applied along their upper inboard edges.

Furthermore, any void between these areas of padding and the area described in Article 14.6.2 must also be completely filled with the same material.

If necessary, and only for driver comfort, an additional piece of padding no greater than 20mm thick may be attached to these headrests provided they are made from the same material which incorporates a low friction surface.

14.6.4 Forward of the side areas of padding further cockpit padding must be provided on each side of the cockpit rim. The purpose of the additional padding is to afford protection to the driver's head in the event of an oblique frontal impact and must therefore be made from the same material as the other three areas of padding with the same cover material.

These extensions must :

- a. Be symmetrically positioned about the car centre plane and a continuation of the side areas of padding.
- b. Be positioned with their upper surfaces at least as high as the survival cell over their entire length.
- c. Have a radius on their upper inboard edge no greater than 10mm.
- d. Be positioned in order that the distance between the two is no less than 320mm.
- e. Be as high as practicable within the constraints of driver comfort.
- f. Extend as far forward as the leading edge of the helmet free volume (the details of which may be found in the Appendix to the Technical and Sporting Regulations)

The cover and its internal structure must have no features that obstruct its freedom to compress to 5% of its uncompressed thickness

- 14.6.5 All of the padding described above must be so installed that if movement of the driver's head, in any expected trajectory during an accident, were to compress the foam fully at any point, his helmet would not make contact with any structural part of the car.
- 14.6.6 No part of the padding described above may obscure sight of any part of the driver's helmet when he is seated normally and viewed from directly above the car.
- 14.6.7 In order to minimise the risk of leg injury during an accident, additional areas of padding must be fitted each side of, and above, the driver's legs.

These areas of padding must:

- a. Be made from a material described in the Appendix to the Technical and Sporting Regulations.
- b. Be no less than 25mm thick over their entire area.
- c. Cover the area situated between the plane B-B and 100mm behind the face of the rearmost pedal when in the inoperative position, as shown in Drawing 4.
- d. Cover the area above the plane A-A shown in Drawing 3.

14.7 Wheel retention

- 14.7.1 All cars, whilst under their own power, must be fitted with dual stage devices which will retain the wheel fastener in the event of it coming loose from both its full fitted position and from any angular position before the fastener begins to engage on the axle thread.
- 14.7.2 Each team must provide test results which demonstrate that all dual stage devices must be able to :
 - a. Withstand 15kN of axial tensile force exerted on the wheel nut in a direction away from the car centre line whilst the wheel nut is fully disengaged from the thread.
 - b. Withstand 250Nm of torque exerted on the wheel nut in the unwinding direction whilst the wheel nut is partially engaged on the thread.
- 14.7.3 Furthermore, the dual stage retaining systems must incorporate a means of allowing the wheel operator/fitter to visually identify an incorrectly fitted fastener.

14.8 Seat fixing and removal

- 14.8.1 In order that an injured driver may be removed from the car in his seat following an accident, all cars must be fitted with a seat which, if it is secured, must be done so with no more than two bolts. If bolts are used, they must be :
 - a. Clearly indicated and easily accessible to rescue crews.
 - b. Fitted vertically.
 - c. Removable with the same tool for all teams and which is issued to all rescue crews.
- 14.8.2 The seat must be equipped with receptacles which permit the fitting of belts to secure the driver and one which will permit the fitting of a head stabilisation device.
- 14.8.3 The seat must be removable without the need to cut or remove any of the seat belts.
- 14.8.4 Details of the tool referred to above, the belt receptacles and the head stabilisation device may be found in the Appendix to the Technical and Sporting Regulations.

14.9 Head and neck supports

No head and neck support worn by the driver may be less than 25mm from any structural part of the car when he is seated in his normal driving position.

ARTICLE 15 : CAR CONSTRUCTION

15.1 Permitted materials

15.1.1 The following is the list of permitted materials. These are the only materials permitted to be used in the construction of the Formula One Car provided only that in all cases the material is available on a non-exclusive basis and under normal commercial terms to all competitors.

Permitted materials :

1. Aluminium alloys.
2. Silicon carbide particulate reinforced aluminium alloy matrix composites.
3. Steel alloys.
4. Cobalt alloys.
5. Copper alloys containing $\leq 2.5\%$ by weight of Beryllium.
6. Titanium alloys (but not for use in fasteners with $<15\text{mm}$ diameter male thread).
7. Magnesium alloys.
8. Nickel based alloys containing $50\% < \text{Ni} < 69\%$.
9. Tungsten alloy.
10. Thermoplastics : monolithic, particulate filled, short fibre reinforced.
11. Thermosets : monolithic, particulate filled, short fibre reinforced.
12. Carbon fibres manufactured from polyacrylonitrile (PAN) precursor. (*)
13. Carbon fibres manufactured from polyacrylonitrile (PAN) precursor which have :
 - A tensile modulus $\leq 550\text{GPa}$.
 - A density $\leq 1.92 \text{ g/cm}^3$.
 - Unidirectional or planar reinforcement within their pre-impregnated form, not including three dimensional weaves or stitched fabrics (but three dimensional preforms and fibre reinforcement using Z-pinning technology are permitted).
 - No carbon nanotubes incorporated within the fibre or its matrix.
 - A permitted matrix, not including a carbon matrix.
14. Aramid fibres.
15. Poly(p-phenylene benzobisoxazole) fibres (e.g. "Zylon").
16. Polyethylene fibres.
17. Polypropylene fibres.
18. E and S Glass fibres.
19. Natural Fibres (i.e. flax, hemp, linen, cotton, bamboo)
20. Sandwich panel cores: Aluminium, Nomex, polymer foams, syntactic foams, balsa wood, carbon foam.
21. The matrix system utilised in all pre-impregnated materials must be epoxy, cyanate ester, phenolic, bismaleimide, polyurethane, polyester or polyimide based. (*)
22. The matrix system utilised in all pre-impregnated materials must be epoxy, cyanate ester or bismaleimide based.
23. Monolithic ceramics.

[Materials marked (*) are permitted only for parts classified as either front, rear or side impact structures, side intrusion panels or suspension members as regulated by Articles 15.4.5, 15.4.6, 15.5.3, 15.5.6, and 10.3 of the Technical Regulations respectively.]

Exceptions :

1. All electrical components (e.g. control boxes, wiring looms, sensors).
2. All seals & rubbers (e.g. rubber boots, o-rings, gaskets, any fluid seals, bump rubbers).
3. Fluids (e.g. water, oils).
4. Tyres.
5. Coatings and platings (e.g. DLC, nitriding, chroming).
6. Paint.
7. Adhesives.
8. Thermal insulation (e.g. felts, gold tape, heat shields).
9. All currently regulated materials (e.g. fuel bladder, headrest, extinguishant, padding, plank).
10. Brake and clutch friction materials.
11. All parts of power units homologated according to Appendix 4 of the Sporting Regulations.

15.1.2 No parts of the car may be made from metallic materials which have a specific modulus of elasticity greater than 40GPa / (g/cm³). Tests to establish conformity will be carried out in accordance with FIA Test Procedure 03/03, a copy of which may be found in the Appendix to the Technical and Sporting Regulations.

15.2 Roll structures

15.2.1 All cars must have two roll structures which are designed to help prevent injury to the driver in the event of the car becoming inverted.

The principal structure must be at least 940mm above the reference plane at a point 30mm behind the plane C-C.

The secondary roll structure, which is not considered part of the survival cell, must be positioned symmetrically about the car centre plane with its front fixing axis 975mm forward of the plane C-C and 640mm above the reference plane. The mounting faces for the rearward fixings must lie on a plane parallel to and 675mm above the reference plane.

The driver's helmet and steering wheel must be arranged such that they lie below a line drawn between the front fixing axis of the secondary roll structure and a point 75mm vertically below the highest point of the principal roll structure.

15.2.2 The principal structure must pass a static load test details of which may be found in Article 17.2. Furthermore, each team must supply detailed calculations which clearly show that it is capable of withstanding the same load when the longitudinal component is applied in a forward direction.

15.2.3 The secondary roll structure attachments to the survival cell must pass two static load tests details of which may be found in Article 17.2. Furthermore, each team must supply detailed calculations which clearly show that these attachments are able to sustain :

- a. The prescribed test loads specified in Articles 17.2.6 and 17.2.7 when fitted with the secondary structure as specified in Article 15.2.5 with the deformation simulated as purely elastic.
- b. A load of 75kN vertically upward on each rear attachment.
- c. A load equivalent to 88kN vertically upward and 88kN longitudinally rearward on the axis of the front attachment.

15.2.4 The principal roll structure must have a minimum enclosed structural cross section of 10000mm², in vertical projection, across a horizontal plane 50mm below its highest point.

The area thus established must not exceed 200mm in length or width and may not be less than 10000mm² below this point.

15.2.5 The secondary roll structure must be supplied by an FIA approved manufacturer. Details of the structure and its mountings may be found in the Appendix to the Technical and Sporting Regulations.

15.2.6 The secondary roll structure may have a fairing attached to it, provided it is bonded to the structure and made of prescribed laminate (details of this laminate may be found in the Appendix to the Technical and Sporting Regulations). No part of any such fairing may have a convex radius of less than 2mm, be more than 20mm from the structure or high speed camera, or lie within the helmet free volume template (details of this volume may be found in the Appendix to the Technical and Sporting Regulations). Furthermore, no part of the fairing may be less than 675mm above the reference plane.

An additional fairing, which is also to be made of the prescribed laminate, is permitted around the secondary roll structure forward mounting and the camera defined in Article 21.2.2. This fairing must lie between 1066mm and 835mm forward of plane C-C, below 685mm above the reference plane and be of minimum width to cover the mounting and camera. Once defined this fairing may be joined to the survival cell upper surface with a fillet of no greater than 10mm.

15.2.7 In order that a car may be lifted quickly in the event of it stopping on the circuit, the principal rollover structure must incorporate an unobstructed opening, whose section measures 60mm x 30mm with internal radii of no more than R15mm, clearly visible in side view, to permit a strap to pass through it.

15.3 Structure behind the driver

The parts of the survival cell immediately behind the driver which separate the cockpit from the car's fuel tank, and which lie less than 150mm from the car centre plane, may be situated no further forward than the line a-b-c-d-e shown in Drawing 2.

In order to validate the integrity of this structure the survival cell must pass an impact test against a solid vertical barrier placed parallel to C-C. Details of the test procedure may be found in Article 16.3.

15.4 Survival cell specifications

15.4.1 Every survival cell must incorporate three FIA supplied transponders for identification purposes. These transponders must be a permanent part of the survival cell, be positioned in accordance with Drawing 6 and as described in the Appendix to the Technical and Sporting Regulations and must be accessible for verification at any time.

15.4.2 The survival cell must have an opening for the driver, the minimum dimensions of which are given in Article 13.1. Any other ducts or openings in the survival cell must either :

- a. Be of the minimum size, and for the sole purpose of, allowing access to mechanical components.
- b. Be for the sole purpose of cooling the driver or mechanical or electrical components, the area of any such duct or opening may not exceed 3000mm².
- c. Be for the sole purpose of routing wiring looms, cables or fluid lines, the total combined area of any such openings must not exceed 7000mm².

15.4.3 Referring to Drawing 5:

The rear face of the cockpit entry template, whilst held in the position described in Article 13.1.1, defines the position of the plane C-C.

The car centre plane is the plane of symmetry of the cockpit entry template, whilst held in the position described in Article 13.1.1, perpendicular to the reference plane and to C-C.

The plane B-B is parallel to and lies 875mm forward of C-C.

The plane A-A is parallel to and lies no less than 1800mm forward of C-C.

The survival cell front bulkhead must be on or forward of the plane A-A.

The external width of the survival cell between the planes B-B and C-C must be no less than 450mm and must be at least 60mm per side wider than the cockpit opening when measured normal to the inside of the cockpit aperture. These minimum dimensions must be maintained over a continuous height of at least 350mm.

Between the planes A-A and B-B, any external cross-section of the survival cell by a plane parallel to C-C must contain a rectangle with radii applied on its four corners, positioned symmetrically about the car centre plane, of the following dimensions :

- a. Width defined by a linear interpolation from 450mm at the plane B-B to 300mm at the plane A-A.
- b. Height defined by a linear interpolation from 400mm at the plane B-B to 275mm at the plane A-A.
- c. Corner radii defined by a linear interpolation from 50mm at the plane B-B to 25mm at the plane A-A.

No part of the survival cell, nor any part rigidly attached to it (with the exception of the panel of prescribed laminate referred to in Article 3.4.2, pitot tubes and antennae), which lies between the plane A-A and a parallel plane 375mm behind of A-A, may lie above a diagonal plane defined by a line on A-A, parallel to and 525mm above the reference plane and a parallel line, 375mm rearward of A-A and 625mm above the reference plane.

The maximum height of the survival cell between the planes A-A and B-B is 625mm above the reference plane.

- 15.4.4** When the test referred to in Article 13.1.1 is carried out and the template is in position with its lower face parallel to and 525mm above the reference plane, the shape of the survival cell must be such that no part of it is visible when viewed from either side of the car. The parts of the survival cell which are situated each side of the driver's head must be no more than 550mm apart.

In order to ensure that the driver's head is not unduly exposed and for him to maintain good lateral visibility he must, when seated normally and looking straight ahead with his head as far back as possible, have his eye visible when viewed from the side. The centre of gravity of his head must lie below the top of the survival cell at this position. When viewed from the side of the car, the centre of gravity of the driver's head will be deemed to be the intersection of a vertical line passing through the centre of his ear and a horizontal line passing through the centre of his eye.

- 15.4.5** In order to give additional protection to the driver in the event of a side impact a flat test panel of uniform construction, which is designed and constructed in order to represent a section of the survival cell sides, must pass a strength test. Details of the test procedure may be found in Article 18.7.

Referring to Drawing 5, with the exception of local reinforcement and/or inserts, all parts of the survival cell which are as wide or wider than the minimum widths stipulated in Article 15.4.3, including any radii applied, must be manufactured to the same specification as a single panel which satisfies the requirements of Article 18.7. However, additional plies may be used and core thickness may be increased where applicable, and local relief applied, provided the FIA technical delegate is satisfied in each case that the overall strength of the structure has been improved by doing so.

Furthermore, parts to this tested specification must cover an area which :

- a. Begins no less than 250mm high at the plane A-A tapering at a linear rate to a minimum of 450mm high at the plane B-B.
- b. Lies between two horizontal lines 100mm and 550mm above the reference plane between the plane B-B and the rear of the survival cell.

Any cut-outs in this defined area forward of a line 300mm rearward of A-A must total less than 15000mm² per side.

- 15.4.6 Once the requirements of Articles 15.4.3, 15.4.5, 15.5.1, 15.5.2, 15.5.4, 15.5.5, 16.1, 16.2, 16.3, 17.1, 17.2, 17.3, 18.1, 18.2, 18.3, 18.4, 18.5, 18.6, 18.7 and 18.9 have been met, two panels no less than 6.2mm thick, constructed from 16 plies of Zylon and two plies of carbon (precise lay-up instructions may be found in the Appendix to the Technical and Sporting Regulations) must then be permanently attached to each side of the survival cell with an appropriate adhesive which has been applied over their entire surface.

These panels must, in side view, cover the area lying between B-B, two planes parallel to and 100mm and 550mm above the reference plane and two lines parallel to and 50mm (measured normal to the lines) behind the lines a-b and b-c (referring to Drawing 2). Furthermore, when viewed from the side, the panel must cover the cockpit entry template shown in side view in Drawing 2.

A 50mm linear taper may be included at the forward and rearward boundaries of the panel, and a 20mm linear taper may be included at the upper boundary of the panel behind a vertical plane parallel to and 375mm forward of C-C (measured normal to the boundaries).

Cut-outs in these panels totalling 35000mm² per side will be permitted for fitting around side impact structures, the survival cell openings described in article 15.4.2c) and essential fixings.

- 15.4.7 Once the requirements of Articles 15.4.4, 15.4.6, 15.5.1, 15.5.2, 15.5.4, 15.5.5, 16.1, 16.2, 16.3, 17.1, 17.2, 17.3, 18.1, 18.2, 18.3, 18.4, 18.5, 18.6, 18.7 and 18.9 have been met one further panel, which may be made in a maximum of three parts but which is no less than 3.0mm thick, constructed from seven plies of Zylon and two plies of carbon (precise lay-up instructions may be found in the Appendix to the Technical and Sporting Regulations), must then be permanently attached to the survival cell with an appropriate adhesive which has been applied over its entire surface including all overlapping joints.

This panel must, in side view, cover the area of the outer skin of the survival cell lying between a plane parallel to and 300mm rearward of A-A, a plane parallel to and 650mm forward of C-C and two planes parallel to and 60mm and 550mm above the reference plane. This will not apply at the top of this panel where any radius permitted by Article 15.4.3 falls inside the minimum permitted survival cell width nor for the area fitted with the panel defined by Article 15.4.6.

A 25mm horizontal linear taper may be included at the forward and rearward boundaries of the panel.

This panel must overlap the panel defined by Article 15.4.6 along all joining edges by a minimum of 25mm. If made in more than one part, all adjacent panels must overlap by a minimum of 25mm. All overlaps may include linear tapers in the thickness of both overlapping parts.

Cut-outs in this panel totalling 15000mm² per side will be permitted for fitting around the survival cell openings described in article 15.4.2c) and essential fixings.

15.5 Survival cell safety requirements

- 15.5.1 The survival cell and frontal absorbing structure must pass an impact test against a solid vertical barrier placed parallel to C-C. Details of the test procedure may be found in Article 16.2.
- 15.5.2 Between the principal and secondary roll structures, two impact absorbing structures must be fitted on each side of the survival cell and must be solidly attached to it. The purpose of these structures is to protect the driver in the event of a lateral impact and, in order to ensure this is the case, strength tests of the mountings must be carried out successfully. Details of the test procedure may be found in Articles 18.9 and 18.10.

The impact absorbing structures must be manufactured and mounted to the survival cell in accordance with the following specifications :

- a. The construction and geometry of the structures may be found in the Appendix to the Technical **and Sporting** Regulations.
- b. The structures must be mounted with the principal axes of their prismatic mounting sections perpendicular to the longitudinal and vertical centre plane of the car, and with the centres of area of their outermost longitudinal vertical cross sections positioned :
 - i. Longitudinally : 500mm (+/-25mm) forward of the plane C-C and within 1mm of each other.
 - ii. Vertically : Between 400mm and 520mm above the reference plane and between 70mm and 190mm above the reference plane for the upper and lower structures respectively.
 - iii. Laterally : Within 1mm of each other.

Refer to the drawings which may be found in the Appendix to the Technical **and Sporting** Regulations.

- c. Mountings must be permanently bonded to the structures to enable them to be attached to the survival cell, each of them must :
 - i. Incorporate a closed end and internal abutment to the impact structure that must be capable of withstanding the lateral load described in Article 18.10 without a structural contribution from the bonded interface.
 - ii. Lie entirely inboard of a plane which lies 292mm inboard of the outermost longitudinal vertical cross section of the impact structure.
 - iii. Be arranged in order that the outermost surface created by an interface between the mounting and structure lies on a vertical surface that is located within the zone indicated in the Appendix to the Technical **and Sporting** Regulations.
 - iv. Be arranged in order that the innermost extent of the bonded interface between the mounting and structure is offset inboard by a minimum of 44mm from the vertical surface defined in (iii) above.
 - v. Be arranged in order that the bonded interface covers the entire external area of the structure between the innermost and outermost extents defined in (iii) and iv) above.
- d. To allow for debris compaction, the internal volume of the :
 - i. Upper structure must be empty outboard of a vertical plane intersecting the structure leading edge at 367mm and trailing edge at 342mm measured from the outermost longitudinal vertical cross section of the impact structure as indicated in the Appendix to the Technical **and Sporting** Regulations.
 - ii. Lower structure must be empty outboard of a vertical plane intersecting the structure leading edge at 382mm and trailing edge at 357mm measured from the outermost longitudinal vertical cross section of the impact structure as indicated in the Appendix to the Technical **and Sporting** Regulations.

No parts which, in the opinion of the FIA technical delegate, would prevent proper function of the impact structures in the event of a lateral impact may be present in the volume lying between 300mm and 700mm forward of the plane C-C, and between 50mm and 600mm above the reference plane, and outboard of a plane 280mm inboard of the outermost longitudinal vertical cross section of the impact structures.

15.5.3 An impact absorbing structure must be fitted behind the gearbox symmetrically about the car centre plane with the centre of area of its rearmost face 300mm (+/-5mm) above the reference plane and no less than 575mm behind the rear wheel centre line.

The rearmost face of the impact structure must be a rectangular section no less than 100mm wide, this minimum width must be maintained over a height of at least 130mm and each corner may incorporate a radius no greater than 10mm.

Furthermore, when viewed from the side, the lowest and highest points of the impact absorbing structure between its rear face and 50mm aft of the rear wheel centre line may not be separated vertically by more than 275 mm.

Between the rear face and the rear wheel centre line no dimension of the area thus defined may diminish nor may any part of the structure or gearbox which is visible from below, other than the permitted radii, be higher than the lower edge of the rear face. Pockets of minimum size within the structure are permitted for the sole purpose of attaching suspension members.

This structure must pass an impact test and must be constructed from materials which will not be substantially affected by the temperatures it is likely to be subjected to during use. Details of the test procedure may be found in Article 16.4.

In order to minimise the likelihood of the structure penetrating a survival cell, it must be designed so that the majority of its material lies evenly around its perimeter. Therefore, the perimeter of every vertical cross section between points 50mm forward of its rear face and 200mm forward of its rear face must be of a uniform construction and, with the exception of minimal local changes for attachments, have a minimum thickness of 1.75mm. Material with a specific gravity of less than 1 will not be considered when calculating these thicknesses and, furthermore, any internal structure must not be thicker than any part of the perimeter at that section.

Only those parts of the structure which genuinely contribute to its performance during the impact test, and which are designed and fitted for that sole purpose, will be considered when assessing compliance with any of the above.

15.5.4 The survival cell must also be subjected to five separate static load tests :

1. On a vertical plane passing through the centre of the fuel tank.
2. On a vertical plane passing through the rearmost point at which the outer end of the forward-most front wheel tether would make contact with the survival cell when swung about the inner attachment.
3. From beneath the fuel tank.
4. On each side of the cockpit opening.
5. From beneath the cockpit floor.

Details of the test procedures may be found in Article 18.2, 18.3, 18.4 and 18.5.

15.5.5 To test the attachments of the frontal, side and rear impact absorbing structures static side load tests must be carried out. Details of these test procedures may be found in Articles 18.6, 18.8 and 18.9.2.

15.5.6 An impact absorbing structure must be fitted in front of the survival cell. This structure need not be an integral part of the survival cell but must be solidly attached to it and be arranged symmetrically about the car centre plane.

The impact absorbing structure must affix to the survival cell using a minimum of four attachments having the same nominal strength.

No part of this structure may lie more than 525mm above the reference plane and its forward-most point must not be less than 1075mm forward of the front wheel centre line.

The plane D-D is defined as a plane parallel to the plane C-C and 50mm rearward of the forward-most point of this impact absorbing structure.

The plane E-E is defined as a plane parallel to the plane C-C and 150mm rearward of the forward-most point of this impact absorbing structure.

This structure must have:

- a. A single external vertical cross-section which area exceeds 9000mm² at the plane D-D. No part of this cross-section may lie less than 135mm above the reference plane and its overall width must not exceed 140mm.

- b. A single external vertical cross-section which area exceeds 20000mm^2 at the plane E-E. The overall width of this cross-section must not exceed 330mm.

When measuring these sections, only parts between the highest point of the section and 100mm vertically below this point, may be considered.

Each external vertical cross-section, taken on planes parallel to the plane C-C between the plane E-E and 150mm forward of the front wheel centre line, must be a single section with an area which exceeds a value given by a linear taper from 20000mm^2 to 60000mm^2 respectively.

Furthermore, all lines drawn normally and externally to a cross-section taken on a plane parallel to C-C and 150mm forward of the front wheel centre line must not cross the car centre plane.

ARTICLE 16 : IMPACT TESTING

16.1 Conditions applicable to all impact tests

- 16.1.1 All tests must be carried out in accordance with FIA Test Procedure 01/00, in the presence of an FIA technical delegate and by using measuring equipment which has been calibrated to the satisfaction of the FIA technical delegate. A copy of the test procedure may be found in the Appendix to the Technical and Sporting Regulations.
- 16.1.2 Any significant modification introduced into any of the structures tested shall require that part to pass a further test.

16.2 Frontal test 1

To simulate in-car conditions, all parts which could materially affect the outcome of the test must be fitted to the test structure which must be solidly fixed to the trolley through the mounting points of the nose structure, but not in such a way as to increase its impact resistance.

If the test facility includes a system to manage excess residual energy (in the event that the nose structure fails to absorb all the test energy), such a system must not in any way modify the results during a successful test.

For the purposes of this test, the total weight of the trolley and test structure shall be 780kg (+1%/-0) and the velocity of impact not less than 15 metres/second.

The resistance of the test structure must be such that during the impact either :

- a. The peak deceleration over the first 100mm of deformation does not exceed 10g.
- b. The peak permissible deceleration increases linearly from 10g at 100mm to 20g at 150mm of deformation.
- c. The peak deceleration over the first 60kJ energy absorption does not exceed 20g.
- d. The average deceleration over the first 150mm of deformation exceeds 2.5g.
- e. The peak deceleration of the trolley does not exceed 45g.

Or :

- a. The peak force over the first 100mm of deformation does not exceed 75kN.
- b. The peak permissible force increases linearly from 75kN at 100mm to 150kN at 150mm of deformation.
- c. The peak force over the first 60kJ energy absorption does not exceed 150kN.
- d. The average force over the first 150mm of deformation exceeds 18.75kN.
- e. The peak force does not exceed 337.5kN.

Furthermore, there must be no damage to the mountings of the nose.

This test must be carried out on the frontal impact absorbing structure which was subjected to the first test described in Article 18.6.

16.3 Frontal test 2

A 50mm (+/-1mm) thick aluminium plate should be attached to the front bulkhead of the survival cell through the mounting points of the frontal impact absorbing structure. The plate should :

- a. Measure 500mm (+/-1mm) wide x 375mm (+/-1mm) high.
- b. Be fitted symmetrically about the car centre plane.
- c. Be fitted in a vertical sense in order to ensure force distribution is similar to that with the nose fitted.

- d. Have six M10 x 30mm holes in the outer face arranged in a 125mm square grid pattern, two squares wide and one square high, about its geometric centre. The test laboratory will then fit a 5mm thick 500mm x 275mm steel plate to these holes using a 5mm washer stack.

All parts which could materially affect the outcome of the test must be fitted to the test structure which must be solidly fixed to the trolley through its engine mounting points but not in such a way as to increase its impact resistance.

The fuel tank must be fitted and must be full of water.

A dummy weighing at least 75kg must be fitted with safety belts described in Article 14.4 fastened. However, with the safety belts unfastened, the dummy must be able to move forwards freely in the cockpit. The dummy shall be equipped with a helmet to FIA8860 or FIA8859 and an FHR to FIA8858 (the weight of the helmet and FHR should be recorded, but should not be included in the 75kg). The safety belts shall be fastened to represent in-race conditions.

The fire extinguishers, as described in Article 14.1 must also be fitted.

For the purposes of this test, the total weight of the trolley and test structure shall be between 900kg and 925kg and the velocity of impact not less than 15 metres/second.

The impact wall must be fitted with six crush tubes which develop a combined 450kN as follows:

- a. 2 x 75kN tubes from T-zero to T-end, directed into the lower left and right M10 attachment points.
- b. 2 x 75kN tubes from T-100mm to T-end, directed into the central M10 attachment points
- c. 2 x 75kN tubes from T-200mm to T-end, directed into the upper left and right M10 attachment points.

The resistance of the test structure must be such that following the impact there is no damage to the survival cell or to the mountings of the safety belts or fire extinguishers.

The maximum deceleration in the chest of the dummy for a cumulative 3ms shall be reported, this being the resultant of data from the three orthogonal axes.

This test may be carried out on any survival cell provided it has been successfully subjected to the tests described in Articles 17.1, 17.2 and 18.2-5. The test must however be carried out on the survival cell which was subjected to the test described in Article 18.6.

Specifications of the crush tubes and test arrangement may be found in the Appendix to the Technical and Sporting Regulations.

16.4 Rear test

All parts which will be fitted behind the rear face of the engine and which could materially affect the outcome of the test must be fitted to the test structure. If suspension members are to be mounted on the structure they must be fitted for the test. The structure and the gearbox must be solidly fixed to the ground and a solid object, having a mass of 780kg (+1%/-0) and travelling at a velocity of not less than 11 metres/second, will be projected into it.

The object used for this test must be flat, measure 450mm (+/-3mm) wide by 550mm (+/-3mm) high and may have a 10mm radius on all edges. Its lower edge must be at the same level as the car reference plane (+/-3mm) and must be so arranged to strike the structure vertically and parallel to the plane C-C.

During the test, the striking object may not pivot in any axis and the crash structure may be supported in any way provided this does not increase the impact resistance of the parts being tested.

The resistance of the test structure must be such that during the impact:

- a. The peak deceleration over the first 225mm of deformation does not exceed 20g.

- b. The maximum deceleration does not exceed 20g for more than a cumulative 15ms, this being measured only in the direction of impact.

Furthermore, all structural damage must be contained within the area behind the rear wheel centre line.

This test must be carried out on the rear impact absorbing structure which was subjected to the test described in Article 18.8.

16.5 Steering column test

The parts referred to in Article 10.4.5 must be fitted to a representative test structure; any other parts which could materially affect the outcome of the test must also be fitted. The test structure must be solidly fixed to the ground and a solid object, having a mass of 8kg (+1%/-0) and travelling at a velocity of not less than 7metres/second, will be projected into it.

The object used for this test must be hemispherical with a diameter of 165mm (+/-1mm).

For the test, the centre of the hemisphere must strike the structure at the centre of the steering wheel along the same axis as the main part of the steering column.

During the test the striking object may not pivot in any axis and the test structure may be supported in any way provided this does not increase the impact resistance of the parts being tested.

The resistance of the test structure must be such that during the impact the peak deceleration of the object does not exceed 80g for more than a cumulative 3ms, this being measured only in the direction of impact.

After the test, all substantial deformation must be within the steering column and the steering wheel quick release mechanism must still function normally.

ARTICLE 17 : ROLL STRUCTURE TESTING

17.1 Principal roll structure test

- 17.1.1 Rubber 3mm thick may be used between the load pads and the roll structure.
- 17.1.2 The peak load must be applied in less than three minutes and be maintained for 10 seconds.
- 17.1.3 Under the load, deformation must be less than 25mm when measured along the loading axis and any structural failure limited to 100mm below the top of the roll structure when measured vertically.
- 17.1.4 Any significant modification introduced into the structure tested shall require that part to pass a further test.
- 17.1.5 A load equivalent to 50kN laterally, 60kN longitudinally in a rearward direction and 90kN vertically, must be applied to the top of the structure through a rigid flat pad which is 200mm in diameter and perpendicular to the loading axis.

During the test, the roll structure must be attached to the survival cell which is supported on its underside on a flat plate, fixed to it through its engine mounting points and wedged laterally by any of the static load test pads described in Article 18.2

17.2 Secondary roll structure attachments tests

- 17.2.1 Rubber 3mm thick may be used between the load pads and the roll structure.
- 17.2.2 A dummy structure, the specification of which may be found in the Appendix to the Technical and Sporting Regulations, must be used in place of the secondary roll structure.
- 17.2.3 The loads shall be applied using a 150mm diameter flat, rigid pad whose centre lies in the specified loading position. The pad shall have only one translational degree of freedom, this being along the axis of load application.
- 17.2.4 For each test, peak loads must be applied in less than three minutes and be maintained for five seconds.
- 17.2.5 After five seconds of application there must be no failure of any part of the survival cell or of any attachment between the structure and the survival cell.
- 17.2.6 A load equivalent to 116kN vertically downward and 46kN longitudinally rearward must be applied at a position 785mm forward of the plane C-C and 810mm above the reference plane and positioned on the car centre plane. A copy of the test procedure may be found in the Appendix to the Technical and Sporting Regulations.

During the test, the structure must be attached to the survival cell which is supported on its underside on a flat plate, fixed to it through its engine mounting points and, optionally, through the front bulkhead and/or the mountings of the lower side impact structures.

- 17.2.7 A load equivalent to 93kN laterally inward and 83kN longitudinally rearward must be applied at a position 590mm forward of the plane C-C and 790mm above the reference plane to the outer surface of the structure. A copy of the test procedure may be found in the Appendix to the Technical and Sporting Regulations.

During the test, the survival cell should be fixed at its rear bulkhead via its engine mounts to a strongwall and supported along its lower face by a surface plate.

The survival cell may be restrained laterally and vertically at its front end by a cradle that wraps around all four sides of the survival cell. This cradle may extend as far forward as the plane A-A, but may not extend further rearwards than 600mm rearwards of the plane A-A.

The side of the survival cell that is opposite to the application point of the Halo test load may be restrained laterally by supports that conform to the sides of the survival cell. These lateral supports may extend no further forward than 200mm forward of the plane B-B, and no higher than 525mm above the reference plane.

ARTICLE 18 : STATIC LOAD TESTING

18.1 Conditions applicable to all static load tests

- 18.1.1 The tests described in Articles 18.2, 18.3, 18.4 and 18.5 must be carried out on every survival cell intended for use. During these tests (on deflections greater than 3.0mm), the deflection across the inner surfaces must not exceed 120% of the deflection obtained on the survival cell used for the tests described in Articles 17.2 and 17.3.
- 18.1.2 Deflections and deformations will be measured at the centre of area of circular load pads and at the top of rectangular pads.
- 18.1.3 All peak loads must be applied in less than three minutes, through a ball jointed junction at the centre of area of the pad, and maintained for 30 seconds.
- 18.1.4 Following the tests described in 18.2, 18.3, 18.4 and 18.5, permanent deformation must be less than 1.0mm (0.5mm in 18.3 and 18.4) after the load has been released for 1 minute.
- 18.1.5 All tests must be carried out by using measuring equipment which has been calibrated to the satisfaction of the FIA technical delegate.
- 18.1.6 A radius of 3mm is permissible on the edges of all load pads and rubber 3mm thick may be placed between them and the test structure.
- 18.1.7 For the tests described in 18.2, 18.3, 18.4 and 18.5, the survival cells must always be produced in an identical condition in order that their weights may be compared. If the weight differs by more than 5% from the one subjected to the impact tests described in Articles 16.2 and 16.3 further frontal and side impact tests and roll structure tests must be carried out.
- 18.1.8 Any significant modification introduced into any of the structures tested shall require that part to pass a further test.
- 18.1.9 All static and dynamic load tests must be performed with the secondary roll structure (whether dummy or otherwise) removed.

18.2 Survival cell side tests

- 18.2.1 For test 1), referred to in Article 15.5.4, pads 100mm long and 300mm high, which conform to the shape of the survival cell, must be placed against the outermost sides of the survival cell with the lower edge of the pad at the lowest part of the survival cell at that section.

A constant transverse horizontal load of 25.0kN will be applied and, under the load, there must be no structural failure of the inner or outer surfaces of the survival cell.
- 18.2.2 For test 2), referred to in Article 15.5.4, pads 200mm in diameter which conform to the shape of the survival cell, must be placed against the outermost sides of the survival cell.

The centre of the pads must pass through the plane mentioned above and the mid-point of the height of the structure at that section.

A constant transverse horizontal load of 30.0kN will be applied to the pads and, under the load, there must be no structural failure of the inner or outer surfaces of the survival cell and the total deflection must not exceed 15mm.

18.3 Survival cell floor test

A pad of 200mm diameter must be placed on the survival cell floor, in a position determined by the FIA technical delegate, and a vertical upwards load of 12.5kN applied.

Under the load, there must be no structural failure of the inner or outer surfaces of the survival cell.

18.4 Cockpit floor test

A pad of 200mm diameter must be placed beneath the survival cell, on the car centre plane and with its centre 600mm forward of the plane C-C, and a vertical upwards load of 15kN applied.

Under the load, there must be no structural failure of the inner or outer surfaces of the survival cell.

18.5 Cockpit rim tests

Two pads, each of which is 50mm in diameter, must be placed on both sides of the cockpit rim with their upper edges at the same height as the top of the cockpit side with their centres at a point 250mm forward of the plane C-C.

A constant transverse horizontal load of 50kN will then be applied at 90° to the car centre plane and, under the load, deformation must be less than 10mm when measured along the loading axis and there must be no structural failure of the inner or outer surfaces of the survival cell.

18.6 Nose push off tests

Noses of identical design must be subjected to two separate tests.

Test 1:

During the first test the nose must be mounted to the same fixture that is used for the frontal impact test 1.

A constant transversal horizontal load must then be applied to one side of the impact absorbing structure, using a pad 200mm long and 300mm high, at a point between 550mm and 750mm from the front wheel axis.

The constant transversal horizontal load shall be applied such that the reaction moment around a vertical axis, when calculated from a point on the front wheel axis, exceeds 35kNm.

All loads must be applied through a ball jointed junction at the centre of area of the pad.

The stiffness of the pad may be chosen by the team.

Rubber or foam may be used between the pad and the test structure.

The centre of area of the pad must pass through the plane mentioned above and the mid-point of the height of the structure at the relevant section. After 30 seconds of application, there must be no failure of the structure or of any attachment between the structure and the fixture.

Test 2:

During the second test the survival cell must be resting on a flat plate and secured to it solidly but not in a way that could increase the strength of the attachments being tested.

A constant transversal horizontal load must then be applied to one side of the impact absorbing structure, using a pad 200mm long and 300mm high, at a point between 550mm and 750mm from the front wheel axis.

The constant transversal horizontal load shall be applied such that the reaction moment around a vertical axis, when calculated from a point on the front wheel axis, exceeds 35kNm.

All loads must be applied through a ball jointed junction at the centre of area of the pad.

The stiffness of the pad may be chosen by the team.

Rubber or foam may be used between the pad and the test structure.

The centre of area of the pad must pass through the plane mentioned above and the mid-point of the height of the structure at the relevant section. After 30 seconds of application, there must be no failure of the structure or of any attachment between the structure and the survival cell.

18.7 Side intrusion test

- 18.7.1 The test must be carried out in accordance with FIA Test Procedure 02/05, in the presence of an FIA technical delegate and by using measuring equipment which has been calibrated to the satisfaction of the FIA technical delegate. A copy of the test procedure may be found in the Appendix to the Technical and Sporting Regulations.
- 18.7.2 The test panel must be 500mm x 500mm and will be tested by forcing a rigid truncated cone through the centre of the panel at a rate of 2mm (+/-1mm) per second until the displacement exceeds 150mm.

During the first 100mm of displacement the load must exceed 250kN and the energy absorption must exceed 6000J. There must be no systematic damage to the border or damage to the fixture before these requirements have been met.

18.8 Rear impact structure push off test

During the test the gearbox and the structure must be solidly fixed to the ground but not in a way that could increase the strength of the attachments being tested.

A constant transversal horizontal load of 40kN must then be applied to one side of the impact absorbing structure, using a pad identical to the ones used in the lateral tests in Article 18.2.1, at a point 400mm behind the rear wheel axis.

The centre of area of the pad must pass through the plane mentioned above and the midpoint of the height of the structure at the relevant section. After 30 seconds of application, there must be no failure of the structure or of any attachment between the structure and the gearbox.

18.9 Side impact structure push off tests

- 18.9.1 Each team must supply detailed calculations which clearly show that the mountings of the upper and lower side impact structures are capable of withstanding :
- Horizontal loads of 40kN and 60kN applied simultaneously to the upper and lower structures respectively in a rearward direction through ball-jointed pads, which may conform to the shape of the structures, measuring 100mm high x 100mm wide and whose centre of area lies 100mm inboard of the centre of the outermost longitudinal vertical cross-section of the impact structure.
 - Horizontal loads of 40kN and 60kN applied simultaneously to the upper and lower structures respectively in a forward direction through ball-jointed pads, which may conform to the shape of the structures, measuring 100mm high x 100mm wide and whose centre of area lies 100mm inboard of the centre of the outermost longitudinal vertical cross-section of the impact structure.
 - A vertical load of 35kN applied in an upward direction to the lower impact structure through a ball-jointed pad, which may conform to the shape of the structure, measuring 200mm long x 100mm wide whose centre of area lies 100mm inboard of the centre of the outermost longitudinal vertical cross section of the impact structure.
 - A vertical load of 27kN applied in a downward direction to the upper impact structure through a ball-jointed pad, which may conform to the shape of the structure, measuring 200mm long x 100mm wide whose centre of area lies 100mm inboard of the centre of the outermost longitudinal vertical cross section of the impact structure.

In all cases the calculations should show that there will be no structural failure of the parts. It should be assumed that ball-jointed pads are used, the joint lying at the centre of area of the pad.

- 18.9.2 These tests may be carried out on any survival cell provided it has been successfully subjected to the tests described in Articles 17.1, 17.2 and 18.2-5. The tests may be performed on either side of the survival cell.

During the push off tests the survival cell must be resting on a flat plate and secured to it solidly but not in a way that could increase the strength of the attachments being tested.

Temporary spacers representing part sections of the panels described in Article 15.4.6 may be incorporated within the assembly of the impact structures to the survival cell. These spacers may not in any way increase the strength of the survival cell being tested.

Dummy test parts may be used in place of the impact structure provided the test part incorporates identical mounting details to those described in Article 15.5.2(c) and does not in any way increase the strength of the attachments being tested.

During the first test rearward horizontal loads of 40kN and 60kN must be applied simultaneously to the upper and lower structures respectively through ball joints or ball-jointed pads whose centre of area lies 100mm inboard of the centre of the outermost cross-section of the dummy impact structures.

During the second test an upward vertical load of 35kN must then be applied to the lower impact absorbing structure using a ball joint or a ball-jointed pad whose centre of area lies 100mm inboard of the centre of the outermost cross section of the dummy lower impact structure.

After five seconds of application there must be no failure of any structures or of any attachment between the structure and the survival cell.

18.10 Side impact structure squeeze tests

This test may be carried out on any survival cell which has been subjected to the tests described in Articles 17.1, 17.2 and 18.2-5. The test may be performed on either side of the survival cell.

During the test, the survival cell may be supported in any way provided this does not increase the strength of the attachments being tested.

Temporary spacers representing part sections of the panels described in Article 15.4.6 may be incorporated within the assembly of the impact structures to the survival cell. These spacers cannot in any way increase the strength of the survival cell being tested.

Dummy test parts may be used in place of the impact structure provided the test parts incorporate identical mounting details to those described in Article 15.5.2(c) and do not in any way increase the strength of the attachments being tested.

Loads of 100kN and 150kN must be applied simultaneously to the dummy upper and lower structures respectively in a lateral direction using a hemispherical pad or ball joint, loading through the centre cross section, 292mm from the outermost longitudinal vertical cross-section of both impact structures.

After five seconds of application there must be no failure of the survival cell or the attachments between the structures and the survival cell.

Each team must supply detailed calculations which clearly show that the mountings of the upper and lower side impact structures satisfy the requirement of 15.5.2(c)(i).

ARTICLE 19 : FUEL

19.1 Purpose of Article 19

- 19.1.1 The purpose of this Article is to ensure that the fuel used in Formula One is petrol as this term is generally understood.
- 19.1.2 The detailed requirements of this Article are intended to ensure the use of fuels that are composed of compounds normally found in commercial fuels and to prohibit the use of specific power-boosting chemical compounds. Acceptable compounds and compound classes are defined in 19.2 and 19.4.3. In addition, to cover the presence of low level impurities, the sum of components lying outside the 19.2 and 19.4.3 definitions are limited to 1% max m/m of the total fuel.
- 19.1.3 Any petrol, which appears to have been formulated in order to subvert the purpose of this regulation, will be deemed to be outside it.

19.2 Definitions

- Paraffins - Straight chain and branched alkanes.
- Olefins - Straight chain and branched mono-olefins and di-olefins.
- Monocyclic mono-olefins (with five or more carbon atoms in the ring) with or without paraffinic side chains.
- Di-olefins - Straight chain or branched or monocyclic hydrocarbons (with five or more carbon atoms in any ring) with or without paraffinic side chains, containing two double bonds per molecule.
- Naphthenes - Monocyclic alkanes (with five or more carbon atoms in the ring) with or without paraffinic side chains.
- Aromatics - Monocyclic and bicyclic aromatic rings with or without paraffinic side chains.
- Oxygenates - Organic compounds containing oxygen.
- Biocomponents - Paraffins, olefins, naphthenes, aromatics and oxygenates, as defined above, derived in whole or part from biological origins. For the purposes of quantification, the biocomponent contribution of a given molecule is defined as the carbon, hydrogen and oxygen atoms from biological origin as a percent of the total molecule, on a mass/mass basis. The biocomponent contribution of a co-produced stream is determined as the bio feedstock percentage on a mass/mass basis.
- Metals - Metals are defined as alkali metals, alkaline earth metals, transition metals, actinides, lanthanides, post-transition metals and metalloids.
- Alkali Metals - Group 1 elements, excluding hydrogen.

19.3 Properties

The only fuel permitted is petrol having the following characteristics

Property	Units	Min	Max	Test Method
(RON+MON)/2		87		ASTM D 2699/D 2700
Oxygen	wt%		3.7	Elemental Analysis
Nitrogen	mg/kg		500	ASTM D 5762

Benzene	wt%		1	GC-MS
DVPE	kPa	45	60 ⁽¹⁾	EN13016-1
Lead	mg/l		5	ASTM D 3237 or ICP-OES
Manganese	mg/l		2	ASTM D 3831 or ICP-OES
Metals (excluding alkali metals)	mg/l		5	ICP-OES
Oxidation Stability	minutes	360		ASTM D 525
Sulphur	mg/kg		10	EN ISO 20846
Electrical conductivity	pS/m	200		ASTM D 2624
Final Boiling Point	°C		210	ISO 3405
Distillation Residue	%v/v		2	ISO 3405

(1) The maximum DVPE may rise to 68kPa if a minimum of 2% bio-methanol and/or bio-ethanol are included in the fuel.

The fuel will be accepted or rejected according to ASTM D 3244 with a confidence limit of 95%.

19.4 Composition of the fuel

19.4.1 The composition of the petrol must comply with the specifications detailed below :

Component	Units	Min	Max	Test Method
Aromatics	wt%		40*	GCMS
Olefins	wt%		17*	GCMS
Total di-olefins	wt%		0.1	GCMS
Total styrene and alkyl derivatives	wt%		0.1	GCMS

* Values corrected for fuel oxygen content.

In addition, the fuel must contain no substance which is capable of exothermic reaction in the absence of external oxygen.

19.4.2 The total of individual hydrocarbon components present at concentrations of less than 5% m/m of the total fuel must be at least 30% m/m of the hydrocarbon component of the fuel.

19.4.3 The only oxygenates permitted are paraffinic mono-alcohols and paraffinic mono-ethers with a final boiling point below 210°C.

19.4.4 A minimum of 5.75% (m/m) of the fuel must comprise bio-components.

19.4.5 Hydrocarbons (as defined in 19.2, but not including di-olefins) and oxygenates (lying outside the 19.4.3 definition) or mixtures thereof, which have been produced from biomass, may be included in Formula One fuel as part of the 5.75% bio-components quota, provided that a suitable analytical procedure is available for their quantification and to verify their biological origin. Their use in F1 fuel will be dependent on evidence indicating that the supplier is genuinely developing these compounds for use in commercial fuels.

19.5 Air

Only ambient air may be mixed with the fuel as an oxidant.

19.6 Safety

19.6.1 All competitors must be in possession of a Material Safety Data Sheet for each type of petrol used. This sheet must be made out in accordance with EC Directive 93/112/EEC and all information contained therein strictly adhered to.

19.7 Fuel approval

19.7.1 Before any fuel may be used in an Event, two separate five litre samples, in suitable containers, must be submitted to the FIA for analysis and approval.

19.7.2 No fuel may be used in an Event without prior written approval of the FIA.

19.7.3 No competitor may have more than **N new** fuel formulations approved for use during a Championship season, **where N = maximum number of fuel formulations as set in the second table of Appendix 2 of F1 Technical Regulations during the 2020 to 2025 Championships. Fuel approval is valid for 2 championship seasons provided the fuel is still compliant with the current technical regulations.**

19.7.4 No competitor may have more than two approved fuels available during an Event.

19.8 Sampling and testing at an Event

19.8.1 All samples will be taken in accordance with the FIA Formula One fuel sampling procedure, a copy of which may be found in the Appendix to the Technical **and Sporting** Regulations.

19.8.2 Fuel density will also be checked and must be within 0.25% of the figure noted during pre-approval analysis of the fuel that is declared to be in use.

19.8.3 Fuel samples taken during an Event will be checked for conformity by using a gas chromatographic technique, which will compare the sample taken with a reference sample of the fuel that is declared to be in use. Samples which differ from the approved fuel in a manner consistent with evaporative loss, will be considered to conform. However, the FIA retains the right to subject the fuel sample to further testing at an FIA approved laboratory.

19.8.4 GC peak areas of the sample will be compared with those obtained from the reference fuel. Increases in any given peak area (relative to its adjacent peak areas) which are greater than 12%, or an absolute amount greater than 0.10% for compounds present at concentrations below 0.8%, will be deemed not to comply.

If a peak is detected in a fuel sample that was absent in the corresponding reference fuel, and its peak area represents more than 0.10% of the summed peak areas of the fuel, the fuel will be deemed not to comply.

If the deviations observed (above) by GC indicate that they are due to incidental mixing with another Formula One fuel to the one declared, but which has been approved by the FIA for use by the team, the fuel sample will be deemed to comply, provided that the adulterant fuel is present at no more than 10% in the sample. Any systematic abuse of mixed fuels will be deemed not to comply.

ARTICLE 20 : ENGINE OIL

20.1 Purpose of Article 20

- 20.1.1** The purpose of this Article is to ensure that the engine oil used in Formula One is engine oil as this term is generally understood. The function of an engine oil is to lubricate moving parts, to improve the overall efficiency of the engine by reducing friction and to reduce wear. It also cleans, inhibits corrosion, improves sealing, and cools the engine by carrying heat away from moving parts. Engine oils should not enhance the properties of the fuel nor energize the combustion. The presence of any component that cannot be rationally associated with the defined functions of the engine oil will be deemed unacceptable.
- 20.1.2** Any engine oil, which appears to have been formulated in order to subvert the purpose of this regulation, will be deemed to be outside it.

20.2 Definitions

Engine oil Fluid serving the purpose of Article 20.1 and comprising base oils and additives as defined below.

Base Oil General :

- a. A base oil is a base stock or blend of base stocks.
- b. A base stock is a lubricant component that is produced by a single manufacturer. Base stocks may be manufactured using a variety of different processes including but not limited to distillation, solvent refining, hydrogen processing, oligomerization, esterification, and re-refining.

Base stock categories :

All base stocks are divided into five general categories :

- a. Group I base stocks contain less than 90 percent saturates and/or greater than 0.03 percent sulphur and have a viscosity index greater than or equal to 80 and less than 120 using the test methods specified in Table 20.1.
- b. Group II base stocks contain greater than or equal to 90 percent saturates and less than or equal to 0.03 percent sulphur and have a viscosity index greater than or equal to 80 and less than 120 using the test methods specified in Table 20.1.
- c. Group III base stocks contain greater than or equal to 90 percent saturates and less than or equal to 0.03 percent sulphur and have a viscosity index greater than or equal to 120 using the test methods specified in Table 20.1.
- d. Group IV base stocks are polyalphaolefins (PAO).
- e. Group V base stocks include all other base stocks not included in Group I, II, III, or IV.

Property	Test Method
Saturates	ASTM D2007
Viscosity index	ASTM D2270
Sulfur (use one listed method)	ASTM D1552 ASTM D2622 ASTM D3120 ASTM D4294 ASTM D4927

Additives: Additives are chemical compounds added to the base oil in small concentrations that improve the performance characteristics of the engine oil.

20.3 Properties

The engine oil must comply with the following characteristics:

Property	Units	Min	Max	Test Method
Kinematic Viscosity (100°C)	cSt	2.8		ASTM D445
HTHS Viscosity at 150°C and Shear Rate of 10^6 s^{-1}	mPa.s	1.4		ASTM D4741
Initial Boiling Point	°C	210		ASTM D7500
Flashpoint	°C	93		ASTM D3828

The oil will be accepted or rejected according to ASTM D 3244 with a confidence limit of 95%.

20.4 Composition of the engine oil

- 20.4.1 In the event that the initial boiling point test (ASTM D7500) suggests the presence of compounds with a boiling point of less than 210°C the sample will be further analysed by GCMS. The total of any components with boiling points less than 210°C must not exceed 0.5% m/m.
- 20.4.2 The engine oil must not contain any organo-metallic petrol additives or other octane boosting petrol additives.

20.5 Safety

- 20.5.1 All competitors must be in possession of a Material Safety Data Sheet for each type of engine oil used. This sheet must be made out in accordance with EC Directive 93/112/EEC or US equivalent and all information contained therein strictly adhered to.

20.6 Engine oil approval

- 20.6.1 Before any engine oil may be used in an Event, two separate one-litre samples, in suitable containers, must be submitted to the FIA for analysis and approval.
- 20.6.2 No engine oil may be used in an Event without prior written approval of the FIA.
- 20.6.3 No competitor may have more than N new engine oil formulations approved for use during a Championship season, where N = maximum number of engine oil formulations as set in the second table of Appendix 2 of F1 Technical Regulations during the 2020 to 2025 Championships. Engine oil approval is valid for 2 championship seasons provided the engine oil is still compliant with the current technical regulations.

20.7 Sampling and testing at an Event

- 20.7.1 Each competitor must declare, prior to every Event, which oil will be used in each of their engines during the Event.
- 20.7.2 For reference purposes, before any oil may be used at an Event, a sample must be submitted to the FIA together with the oil reference number.
- 20.7.3 No competitor may use more than one oil in a given engine during an Event.
- 20.7.4 Engine oil samples taken during an Event will be checked for conformity by using a Fourier transform infrared (FTIR) technique, which will compare the sample taken with that submitted at the start of the event. Samples which differ from the reference engine oil in a manner consistent with fuel dilution, engine fluids contamination and oil ageing as a result of

normal engine operation, will be considered to conform. Samples which differ from the reference engine oil in a manner consistent with the mixing with other engine oils, which have been approved by the FIA for use by the team, will be deemed to comply, provided that the adulterant oils are in total present at no more than 10% in the sample. However, the FIA retains the right to subject the oil sample to further testing at an FIA approved laboratory.

ARTICLE 21 : TELEVISION CAMERAS AND TIMING TRANSPONDERS

21.1 Presence of cameras and camera housings

- 21.1.1 All cars must be fitted with at least six cameras or camera housings at all times throughout the Event.
- 21.1.2 All cars must be equipped with six positions in which cameras or camera housings can be fitted. Referring to Drawing 6, all cars must carry (i) a camera in positions 4, and 5 and (ii) a camera or camera housing in positions 1, 2 (both sides) and 3.
- 21.1.3 Details concerning the technical specification of all cameras may be found in the Appendix to the Technical and Sporting Regulations.
- 21.1.4 Camera housings, when used, must be fitted in the same location as cameras, and satisfy all the relevant regulations. Details concerning the size and weight of all camera housings may be found in the Appendix to the Technical and Sporting Regulations.

Any decision as to whether a camera or camera housing is fitted in those positions will be by agreement between the relevant Competitor and the Commercial Rights Holder.

21.2 Location and fitting of camera equipment

- 21.2.1 Any camera fitted in positions 2, 3 or 4 shown in Drawing 6 must be mounted in order that its major axis does not subtend an angle greater than 1° to the reference plane, and its lateral axis is normal to the car centre plane.
- 21.2.2 Any camera fitted in position 1 must be fitted above the survival cell, forward of the cockpit opening, rearwards of the forward attachment of the Secondary Roll Structure described in Article 15.2.3. and symmetrically with respect to the car centre plane, with the camera pointing towards the driver. The electronic conditioning unit for this camera must be positioned within the survival cell and in accordance with the Appendix to the Technical and Sporting Regulations.
- 21.2.3 When viewed from the side of the car, the entire camera in position 2 must lie within the area formed by two vertical lines 150mm and 450mm forward of the front wheel centre line, a horizontal line 325mm above the reference plane and a diagonal line from a point on A-A and 550mm above the reference plane to a point 50mm rearward of the forward-most point of the impact absorbing structure defined in Article 15.5.6 and 220mm above the reference plane. Furthermore, the entire camera in position 2 must be mounted more than 150mm from car centre plane.
- Any camera fitted in the left hand position 2 shown in Drawing 6 must be mounted in order that its major axis where passing through the centre of the camera lens does not intersect any part of the car lying forward of the camera
- Any part provided by the Competitor for the purpose of aligning the camera in position 2 correctly will be considered part of the camera provided it does not exceed 15mm in width and is being fitted for that sole purpose.
- 21.2.4 The camera fitted in position 3 must be mounted in order that its forward-most point is situated between 140mm and 300mm rearward of the plane C-C and 870mm (+/-5mm) above the reference plane. The inner face of the camera unit should be between 120mm and 150mm from the car centre plane.
- Any part provided by the Competitor for the purpose of aligning the camera in position 3 must be an extrusion of the camera unit profile. A radius of up to 10mm will be permitted where this component meets the bodywork or survival cell.
- 21.2.5 The camera fitted in position 4 must be mounted in order that its forward-most point is no more than 80mm rearward of the plane C-C.
- 21.2.6 The camera fitted in position 5 should be mounted parallel to the reference plane, symmetrically about the car centre plane and at least 400mm forward of the cockpit opening.

In order to not impinge on its 360deg image, any shrouding or cut-out should be no higher than shoulder X, as defined in the Appendix to the Technical and Sporting Regulations

21.3 Transponders

All cars must be fitted with two timing transponders supplied by the officially appointed timekeepers. These transponders must be fitted in strict accordance with the instructions detailed in the Appendix to the Technical and Sporting Regulations. Teams must use their best endeavours to ensure that the transponders are in working order at all times.

21.4 Installation

Competitors must be notified of any changes to the camera or transponder installation instructions before 30 June of the previous season.

ARTICLE 22: COMPONENTS' CLASSIFICATION AND HOMOLOGATION

22.1 Definitions

In this Article 22:

"Associate" means, with respect to a Competitor in the Championship (and any entity representing that Competitor):

- a. any other person or entity (including any corporate or unincorporated body) that (directly or indirectly):
 - i. owns share capital or business assets of the Competitor; or
 - ii. has the power to exercise voting rights in relation to the Competitor; or
 - iii. has the power to appoint members of the supervisory board, board of directors or bodies legally representing the Competitor; or
 - iv. has the power to conduct the affairs of the Competitor by constitutional documents or agreement or otherwise; and
- b. any other person or entity in the same legal group structure as the Competitor from time to time; and
- c. any agent, contractor (or sub-contractor) or other person or entity (including any corporate or unincorporated body) that is set up or used by a Competitor to circumvent the requirements of this Article 22.

"Outsourcing" means procuring goods or services by contract with an external supplier.

"Design Specification" means, in respect of a component all design (including three-dimensional geometry, tolerances, materials, surface finishes and design standards), manufacturing, installation and operational information related to that component.

And for the purposes of these Technical Regulations, including in this Article 22:

"Intellectual Property" means:

- a. patents, rights to inventions, designs, copyright and related rights, database rights, trade marks and trade names, rights in get-up and related goodwill and the right to sue for passing off or unfair competition (in each case whether registered, registerable or unregistered);
- b. proprietary rights in domain names;
- c. rights to use, and protect the confidentiality of, trade secrets, know-how and confidential information;
- d. applications, and rights to apply for and be granted registrations, including extensions and renewals of, such rights; and
- e. all other rights of a similar nature or having an equivalent effect anywhere in the world.

22.2 General Principles

22.2.1 Classification:

- a. Subject to Article 22.2.1 (d), all components used in Formula One cars (with the exception of the secondary roll structure defined in Article 15.2.5 and the two impact absorbing structures defined in Article 15.5.2) and all equipment used to support a Competitor's operations during a Championship shall be classified as a Listed Team Component (LTC), or a Standard Supply Component (SSC), or a Transferable Component (TRC), or a Free Supply Component (FSC), or (starting from 2022) an Open Source Component (OSC), each as defined in Article 22.3-22.6 (inclusive).
- b. Unless otherwise specified, such components/equipment will be classified as FSC for 2021.

- c. All Aerodynamic Components described in Article 3 or Articles 11.4, 11.5 and 11.6 of these Technical Regulations are LTC.
 - d. Power Unit components shown in the column “Definitions” of the table in Appendix 2 of the Technical Regulations do not fall under any of the five categories set out in this Article.
 - e. For 2021, a number of components will be homologated and remain unchanged from a specific moment in time. Full details about these components can be found in Article 22.7.
 - f. In cases of doubt, the FIA should be consulted and shall determine the classification of the particular component or piece of equipment, should that differ from the default classification mentioned in Article 22.2.1(b) above.
- 22.2.2** For the purposes of the remaining provisions of this Article 22, any reference to any Competitor shall include (a) any Associate of such Competitor; and (b) any external entity (i) working on behalf of a Competitor or (ii) working for its own purposes and subsequently providing the results of its work to a Competitor.
- 22.2.3** For the purposes of the remaining provisions of this Article 22, any reference to a “component” may also refer to complete assemblies.
- 22.2.4** No Competitor may use movement of personnel (whether employee, consultant, contractor, secondee or any other type of permanent or temporary personnel) with another Competitor, either directly or via an external entity, for the purpose of circumventing the requirements of this Article 22.
- 22.2.5** From time to time the FIA may request that a competitor shares certain information in connection with this Article 22 with the FIA (a) so that the FIA may share with the other competitors for safety reasons only, or (b) to assist the FIA in considering future amendments to the Technical Regulations, subject in each case to receiving the appropriate undertaking of confidentiality from the FIA.
- 22.2.6** Except as otherwise expressly permitted by these Technical Regulations or by the FIA, no competitor may directly or indirectly disclose or transfer any Intellectual Property to another competitor that is reasonably likely to impact upon the performance of the receiving competitor, and no competitor may directly or indirectly obtain (by any means) the same from another competitor.
- 22.2.7** The Design Specifications for components that will be classed as OSC in 2022 will be made available to all Competitors for use as contemplated by these Technical Regulations by placing them on a server specified by the FIA. In accordance with the server terms and conditions, a Competitor who accesses and uses such Design Specifications will disclaim, waive and release any claims for loss or damages arising from such access and use to the greatest extent permitted by applicable law. The server terms and conditions may be found in Appendix 5.
- 22.2.8** Where a Competitor is made responsible under these Technical Regulations for raising any issues of safety, incompatibility and/or reliability of a component that it uses on its car, it shall not make any claim against any other party that is inconsistent with that responsibility.
- 22.2.9** Competitors may make available to other Competitors test facilities and equipment such as (but not limited to) wind tunnels or dynamometers. The Intellectual Property involved in the operation of such shared facilities may be used by and/or disclosed to the sharing party but the results of any experimental or test work carried out on such facilities may only be used by the originator of the work. Where facilities are shared, robust processes must be put in place to ensure there is no transfer of Intellectual Property through common personnel and that all data can only be accessed by the originator of the work. Any such sharing of facilities must be declared to the FIA with a full description of the work that will be carried out, and also of the processes that will be put in place in order to avoid an exchange of information that could lead to the transfer of knowledge leading to the performance enhancement of an LTC (as required by Article 22.3.4), or a TRC or FSC (as required by Article 22.5.8) or an OSC (as required by Article 22.6.9).

22.3 Listed Team Components (LTC)

- 22.3.1** “Listed Team Components” (LTC) are components whose design, manufacture and Intellectual Property is owned and/or controlled by a single Competitor or its agents on an exclusive basis (including, without limitation, the components identified as such in Article 22.7).
- 22.3.2** A Competitor may only use LTC in its Formula One cars that it has designed (including, for the avoidance of doubt, its three-dimensional shape and the evolution history leading to it, any preliminary designs, simulations, wind tunnel tests, and analysis) and manufactured itself. However, this does not prevent the Competitor Outsourcing any R&D, engineering and/or CAD design, and/or the manufacture of any LTC to a third party (including, for the avoidance of doubt, an Associate of such Competitor) provided that:
- a. the Competitor retains the exclusive right to use the LTC in Formula One for so long as it competes in Formula One;
 - b. the third party to whom manufacture of the LTC is Outsourced may not be another Competitor or an Associate to another Competitor; and
 - c. the third party to whom design of the LTC is Outsourced may not be another Competitor, an Associate to another Competitor, or a party that directly or indirectly designs LTCs or TRCs for any other Competitor.
- 22.3.3** Although it is permissible to be influenced by the design or concept of a Competitor's LTC using information that must potentially be available to all Competitors, this information may only be obtained at Events or Tests (as defined respectively in Articles 5 and 10.5 of the Sporting Regulations), and no Competitor may design its LTCs based on “reverse engineering” of another Competitor's LTC (or parts that were classified as “Listed Parts” under Appendix 6 of the 2019 or 2020 Sporting Regulations). For the purpose of this Article, “reverse engineering” shall mean:
- a. The use of photographs or images, combined with software that converts them to point clouds, curves, surfaces, or allows CAD geometry to be overlaid onto or extracted from the photograph or image
 - b. The use of stereophotogrammetry, 3D cameras or any 3D stereoscopic techniques
 - c. Any form of contact or non-contact surface scanning
 - d. Any technique that projects points or curves on a surface so as to facilitate the reverse-engineering process

In cases where isolated features of a Competitor's LTC(s) may closely resemble the features of another Competitor's LTC(s), it will be the role of the FIA to determine whether this resemblance is the result of reverse engineering or of legitimate independent work. The following further provisions apply:

- e. All Competitors must provide to the FIA, upon request, any data or other information that is required to demonstrate compliance with this Article.
- f. For all LTCs used during the 2021 Championship, the restrictions described in this Article apply to their entire design process, including actions carried out before the 2021 calendar year.
- g. For the purposes of assessing compliance with Article 22.3, and with Article 6.3 of the Sporting Regulations, any LTC classified as a 'Listed Part' under Appendix 6 of the 2019 or 2020 Sporting Regulations that was used by a Competitor during an Event of the 2019 Championship or during the first completed Event of the 2020 Championship will be deemed to have been designed by the Competitor and not be based on reverse engineering, irrespective of its origin, and the Competitor may therefore use this LTC, or develop it further, subject to such developments complying with the requirements of this Article.

communicated to all Competitors, and will continue to be applied until the relevant supplier introduces a new specification that resolves the reliability, compatibility or safety concern.

- 22.4.4 The use of a SSC is mandatory and the particular function of that SSC must not be by-passed, replaced, duplicated or complemented by another component.
- 22.4.5 No Competitor may, either directly or via a third party pass any information (including but not limited to data, know how, operating procedures, properties and calibrations) or methodology (including but not limited to simulation software, analysis tools, etc.) which can be used to enhance the performance of a SSC to another Competitor, or receive any such methodology from another Competitor.

22.5 Transferable Components (TRC) and Free Supply Components (FSC)

- 22.5.1 “**Transferable Components**” (TRC) are components whose design, manufacture and Intellectual Property resides within a single Supplying Competitor, or third party, but can be supplied to another Customer Competitor (including, without limitation, the components identified as such in Article 22.7).

For 2021 only, “**Free Supply Components**” (FSC) will follow identical technical regulation requirements to TRC, as outlined in this Article 22.5. However, their treatment by the 2021 Financial Regulations will be different.

- 22.5.2 The provisions of this Article 22.5 regard the supply of such TRC or FSC components by a Supplying Competitor or a third party to a Customer Competitor. In the event a component classified as TRC or FSC does not get supplied to any Customer Competitor, the rules governing such a component will be identical to the rules governing LTC’s. Furthermore, with regard to any component classed as TRC, any two teams who are not operating in a Supplying Competitor-Customer Competitor relationship with regard to the specific component must observe all the rules that govern LTC’s.
- 22.5.3 The Supplying Competitor (or its agent) must own and/or control all rights, information and/or data of any nature (including all aspects of the design, manufacturing, know-how, operating procedures, properties and calibrations) in respect of a TRC or FSC, but it may supply such TRC or FSC to other Competitors.
- 22.5.4 The components supplied as TRC or FSC by a Supplying Competitor to a Customer Competitor must be components identical to those used by the Supplying Competitor in the same Championship or a previous one. Under no circumstances is it permitted for the Supplying Competitor to carry out the design or manufacture of bespoke TRC’s for the specific use by a Customer Competitor. The Customer Competitor may however elect to replace or modify sub components of a TRC or FSC, but in that case all the related additional work (including, but not limited to Research and Development, simulations, design, manufacture etc.) must be carried out by the Customer Competitor or its agents. In exceptional circumstances, and with the prior approval of the FIA, the Supplying Competitor may provide assistance to the Customer Competitor for the resolution of reliability or safety issues regarding the TRC or FSC.
- 22.5.5 The Supplying Competitor may outsource the design (intended for this Article as any R&D, Engineering and CAD design) and/or manufacture of any TRC or FSC to a third party (including, for the avoidance of doubt, an Associate of such Competitor) provided that:
 - a. the third party to whom manufacture of the TRC or FSC is Outsourced may not be another Competitor; and
 - b. the third party to whom design of the TRC or FSC is Outsourced may not be another Competitor, or a party that directly or indirectly designs TRCs, FSCs or LTCs for any other Competitor.
- 22.5.6 The Supplying Competitor (or its agents) must have exclusive ownership of and/or control over any and all rights, information or data of any nature (including but not limited to all aspects of the design, manufacturing, know-how, operating procedures, properties and calibrations) in respect of the TRC or FSC in its Formula One cars. However, notwithstanding the foregoing:

- a. the use of specialist Intellectual Property or technology of third parties is permitted in respect of TRCs or FSCs, provided that this Intellectual Property or technology is commercially available to all Competitors. The principal parameters of such components must in any case be determined by the Competitor and not be available to other Competitors.
 - b. similarly, it is permitted to use commercially available sub-components or sub-assemblies in respect of TRCs or FSCs, provided these are commercially available to all Competitors.
- 22.5.7** A third party unrelated to any Competitor may supply a TRC or FSC to a Customer Competitor, provided that it also offers to supply the TRC or FSC to any other Customer Competitor on similar commercial terms.
- 22.5.8** In respect of the conditions at Article 22.3.4, any information on TRC passed on or received by a Competitor or any consultancy or any other kind of services involving a Competitor in relation to TRC or FSC shall be strictly limited to the designs or drawings necessary for the integration of the TRC or FSC into the design of the car and/or the data of the TRC or FSC necessary for the correct operation of the TRC or FSC on the car. For the avoidance of doubt, the following passage of information is strictly prohibited:
- a. Information specific to a particular circuit or race (e.g. suspension setup information)
 - b. Software or methodology for the optimisation of the performance of a TRC or FSC (e.g. simulation software)

22.6 Open Source Components (OSC) for 2022

- 22.6.1** “Open Source Components” (OSC) are components, starting from 2022, whose Design Specification and Intellectual Property is made available to all Competitors through the mechanisms defined in this Article 22.6 (including, without limitation, the components identified as such in Article 22.7).
- 22.6.2** For all OSC in use by all Competitors, the Design Specification must reside on a designated server specified by the FIA, and be accessible by all Competitors. Details about the server, access credentials and file naming and format conventions may be found in the Appendix to the Technical and Sporting Regulations.
- 22.6.3** Any Competitor who designs a new OSC or modifies the Design Specification of a previous OSC must upload the new Design Specification to the designated server before the first track usage of this OSC in either a Competition or a test.
- 22.6.4** Any Competitor who creates a new, or modifies an existing, Design Specification of an OSC or any OSC manufactured to a Design Specification grants an irrevocable, royalty-free, non-exclusive, worldwide licence to all other Competitors to use and modify any of its Intellectual Property subsisting in such OSCs or Design Specifications to the extent contemplated by these Technical Regulations. A Competitor may only exercise its rights under such licence subject to it agreeing to be bound by the terms and conditions applicable to the FIA's designated server.
- 22.6.5** In the event the OSC or the Design Specification of any OSC contains proprietary information and/or Intellectual Property of a third party supplier, this must be made clear by the Competitor when uploading the Design Specification of the OSC, and use of the uploaded Design Specification (and any OSC manufactured to that Design Specification) by any other Competitor exercising its rights in accordance with these Technical Regulations must be approved in writing by the third party supplier, with a copy of such approval to be available to the FIA on request. Should it become necessary to remove any sensitive information, then the uploaded Design Specification must:
- a. Contain a clear reference to the supplier in question.
 - b. Contain sufficient information for another Competitor to be able to order an identical component from the supplier.

- c. Contain all the necessary information to permit another Competitor to install the OSC in their own car.
- 22.6.6** All Competitors are obliged to declare to the FIA the version of each OSC that gets used on their car. This information will be made available to all Competitors.
- 22.6.7** The complete responsibility for the installation and operation of an OSC (including any matters related to its function, performance, reliability, compatibility or safety) resides with the Competitor who uses this version of the OSC. Notwithstanding this provision, any Competitor who encounters a functionality, reliability, compatibility or safety issue with a particular version of an OSC is obliged to provide such information to the FIA and all other Competitors via the designated server.
- 22.6.8** OSC's may be provided from one Competitor to another, provided that the specification supplied from the Supplying Competitor to the Customer Competitor is of the same specification utilized by the Supplying Competitor.
- 22.6.9** No Competitor may, either directly or via a third party pass any information (including but not limited to data, know how, operating procedures, properties and calibrations) or methodology (including but not limited to simulation software, analysis tools, etc.) which can be used to enhance the performance of an OSC to another Competitor, or receive any such information or methodology from another Competitor.
- 22.6.10** For the components included in the following table, designated as OSC for 2022, Competitors must upload the design specifications of the equivalent components in use during the 2021 Championship, no later than 15 July 2021, regardless of the suitability of these components to the 2022 Technical Regulations:

Component name	Ref.
Pedals	1K
Rear wing adjuster (DRS)	2C
Drive shaft	3L
Steering column	4M
Steering wheel and quick release	4N
Brake disc, disk bell and pad assembly	5A
Brake calipers	5B
Rear brake control system (BBW)	5C
Brake master cylinder	5D
Fire Extinguishers	12A
Water drink system	13A

The column "Ref." refers to the definition of the component perimeters in the table of Appendix 4.

22.7 Homologated Components (HC) for 2021

- 22.7.1** In order to significantly reduce the design, R&D and components costs for 2020 and 2021, a number of components or assemblies will be homologated for the 2021 Championship. Such components or assemblies will be known as "Homologated Components" (HC) and will be referred to with the suffix "-H" following their main classification (e.g. "LTC-H", "TRC-H"). TCC events as defined by the Sporting Regulations are exempt from the Homologated Components requirements of Article 22.7, Appendix 2 and Appendix 4.
- 22.7.2** The specification of HC during the 2021 Championship will be determined by their specification in one of four possible freeze dates:
- The earliest date between the date of P1 of the first Competition of the 2020 Championship, or 1 September 2020. This date is denoted as "R1-2020" for the purposes of this Article.

- b. 30 September 2020. This date is denoted as “mid-2020” for the purposes of this Article.
- c. The date of P1 of the first Competition of the 2021 Championship. This date is denoted as “R1-2021” for the purposes of this Article.
- d. One week before the Monaco Event for front suspension members used only at this event and permitted under the exception in Appendix 4.

22.7.3 From the defined freeze date, only a single specification of any assembly, system, or component classified as HC may be used during the 2021 Championship, and this specification may not change, save for the following exceptions:

- a. Minimal changes for safety, reliability or cost reasons.
- b. Changes for driver comfort, or for the installation of a new driver. For the avoidance of doubt, changes which are intended to improve the functionality of the driver will not be accepted (e.g. new switch layout to increase the number of available options).
- c. Changes of supplier, if the existing HC supplier is unable to continue the supply of a component or sub-assembly. In such cases, the specification of the new component or sub-assembly must be as close as possible to that of the component or sub-assembly it replaces.
- d. Changes due to regulation changes, legality fixes or the installation of FIA-mandated components.
- e. Minimal setup options of parts of the HC. Such options may include, but are not limited to washers, spacers, spring stiffness, brackets, etc. In any case the FIA must be satisfied that these setup options do not constitute a fundamentally new design or specification of the HC.
- f. Minimal modifications that can be applied onto a finished HC of the original design specification. Such modifications may include, but are not limited to, minor local machining, the drilling of a hole, or minor local reinforcement, which in the opinion of the FIA do not have a significant cost or functionality implication.

In such cases, the modified HC must have no performance or weight improvement in comparison to the component or assembly it replaces.

In all cases, the Competitor must seek the approval of the FIA with full details of the planned modification. The FIA must be fully satisfied that the reasons of the suggested modification are the ones claimed by the Competitor, and that such modifications are consistent with the intent of this Article, before granting their permission for the suggested modifications. In any case, feedback by the FIA will be given within 7 days from receiving the request from the team.

In the event the Competitor wishes to sign-off modifications carried out under the provisions of this Article, the Competitor must seek the approval of the FIA for the sign-off process, which must be restricted to free practice sessions during a Competition. The Competitor may then elect to confirm the modification for subsequent use.

More than one specification of the HC may be used if explicitly allowed by the table in Appendix 4. For short periods of time, and with the approval of the FIA, an older specification of the HC may be used as a spare should the new specification not be available in sufficient numbers for manufacturing reasons.

22.7.4 Notwithstanding the objectives and provisions of this Article 22.7, Competitors may use up to a total of two (2) tokens for the modification of certain homologated components after the specified freeze date. This provision applies only for HCs with R1-2020 or mid-2020 freeze dates. For the avoidance of doubt, if one or two tokens have been used during the 2020 Championship, as allowed under Article 22.1.4 of the 2020 Technical Regulations, the updated components of the 2020 Championship must continue to be used for the 2021 Championship, and these tokens will be considered as used also for 2021.

In order to use this provision, the Competitor must observe the following timeframe in relation to notifying the FIA:

- D1: notify the FIA of the intent to modify an HC, with an estimate on the parts it affects and a brief description of the reasons
- D2: provide the FIA with a full specification of the intended changes of the HC and any affected components
- D3: provide the FIA with a detailed scheme of the intended changes

For all three deadlines, the FIA will undertake to respond to the Competitor within a week in relation to the proposed modification.

The following table shows the deadlines of these three dates in accordance to the HC that is getting modified:

	R1-2020	Mid-2020	R1-2021
D1	5 days after the end of the 2020 shutdown	22 July 2020	Not possible
D2	14 days after the end of the 2020 shutdown	5 August 2020	
D3	60 days after the end of the 2020 shutdown	21 September 2020	

The following further provisions apply in relation to HCs modified using the token system defined in this Article:

- a. Minor consequential changes to adjacent components will be accepted with the approval of the FIA.
- b. Following a declaration within the set time scales, should the Competitor wish to abandon the related project, it will not be possible to re-use the tokens for other purposes.
- c. In the case an HC component has been revised either through the use of tokens, or before its homologation date but does not meet the Competitors expectations, it will be permitted to revert back to the original specification of this HC component within five Competitions from its first introduction. Any tokens used may not be re-used for other purposes, and the new specification must be discarded.

22.7.5 In the event a Customer Competitor buys a TRC-H or FSC-H from a Supplying Competitor, the following provisions apply:

- a. Any tokens used by the Supplying Competitor for modifications to that TRC-H or FSC-H will also apply to the Customer Competitor, should the Customer Competitor decide to use the updated component. In any case, the Supplying Competitor should use their best endeavours to ensure that such an update (and use of tokens) is not mandatory for the Customer Competitor.
- b. In the event the Customer Competitor has used for that TRC-H or FSC-H the 2019 specification of the Supplying Competitor during the 2020 season, but wishes to upgrade to the 2020 specification for the 2021 season, this change will be acceptable without the use of any tokens.

22.7.6 In the event a Competitor wishes to carry out a completely new Power Unit installation (whether because of a new Power Unit Architecture, or because of the change of Power Unit supplier), affecting both the survival cell and the gearbox, no further tokens may be used for other components under the provisions of Article 22.7.4.

In such cases, the Competitor must satisfy the FIA that the proposed changes to the design of the affected HCs are the minimum necessary to allow for the new installation of the Power

Unit. No further changes to the affected HCs may be carried out, nor may the adopted technology be different from the original HCs.

In order to fulfil this requirement, the Competitor must organise with the FIA a schedule of regular CAD design reviews, in such way that should the FIA have a concern about the proposed extent of the modifications, a remedial action can be decided in a timely manner.

22.7.7 The FIA will communicate to the Competitors the exact procedure through which it will verify compliance with the provisions of Article **22.7** for all components designated as HCs.

22.8 Classification, homologation and perimeter of each group

A complete list of the parts' classification and homologation status, freeze date and tokens, as well as a definition of the perimeter of each assembly can be found in Appendix 4.

Components which are part of an assembly will assume the classification status of that assembly unless otherwise specified.

ARTICLE 23: FINAL TEXT

The final text for these regulations shall be the English version should any dispute arise over their interpretation.

APPENDIX 1: DRAWINGS

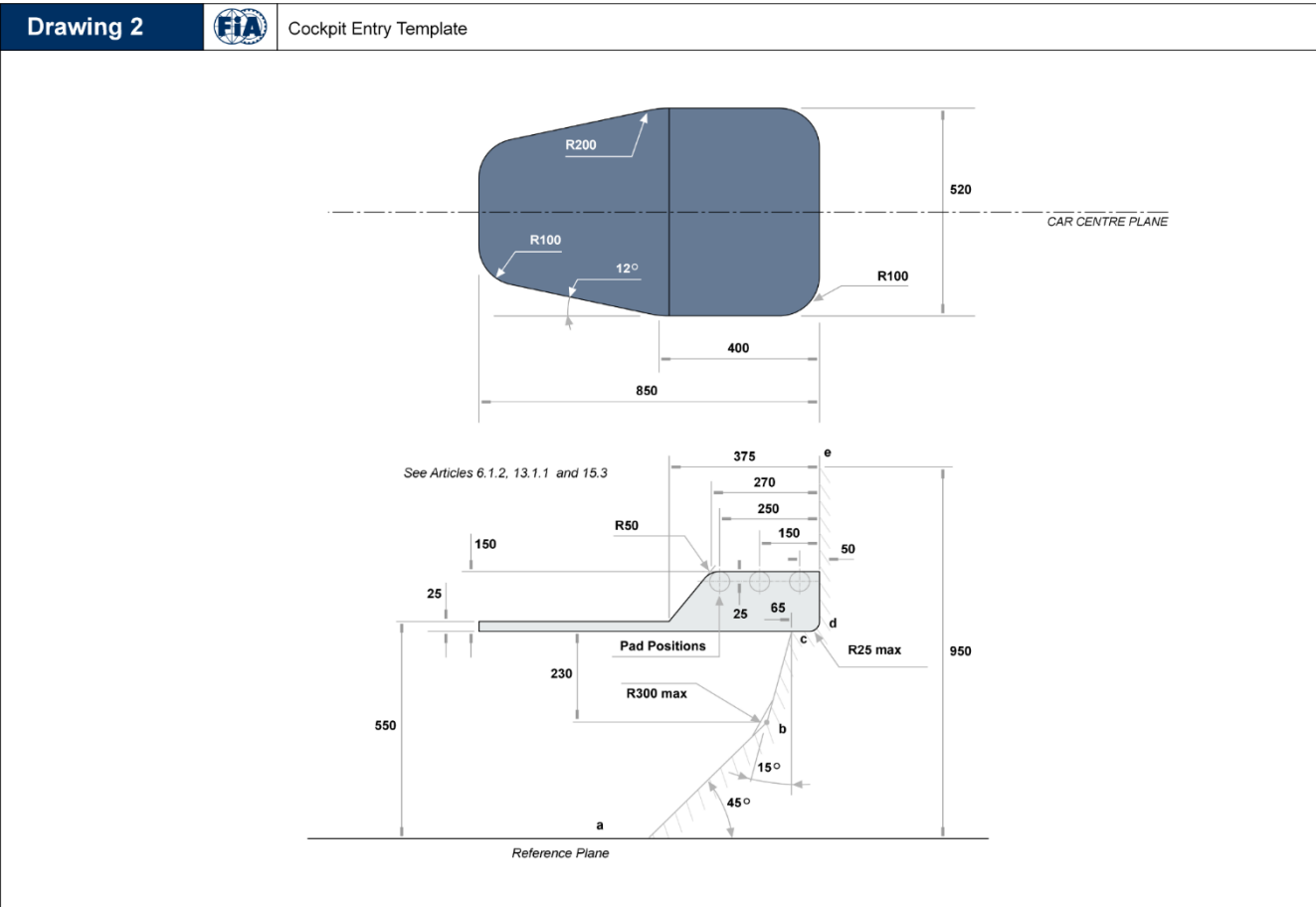
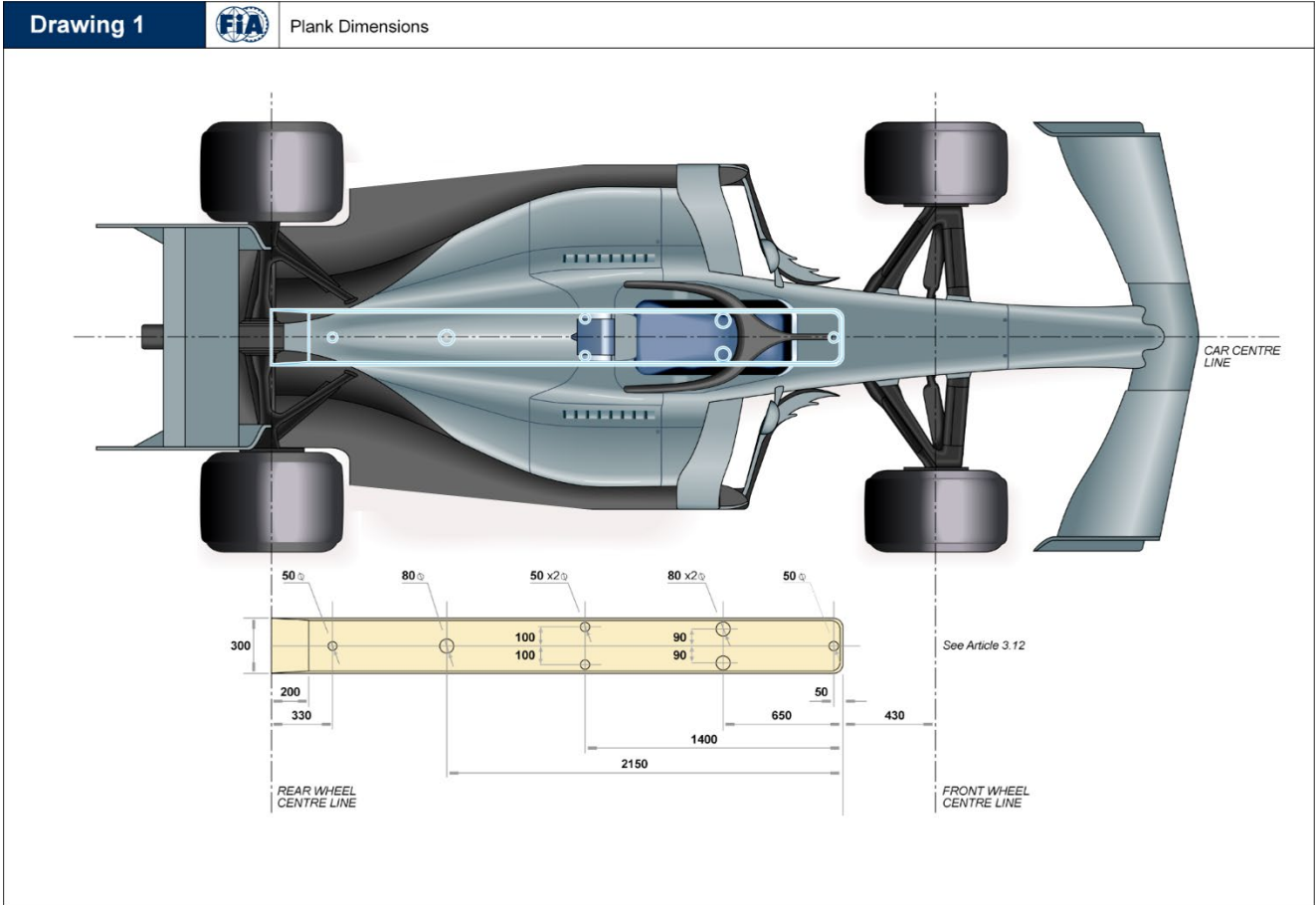

Drawing 3



Cockpit Cross Section Template

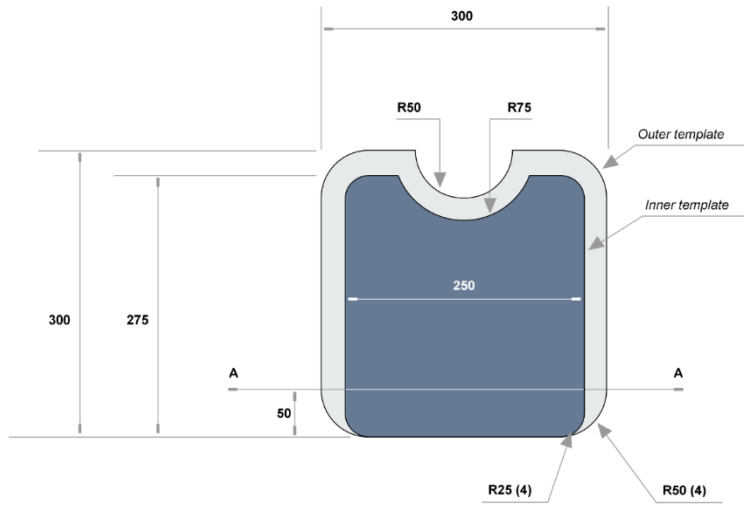

See Article 13.3.1 & Article 14.6.7

Drawing 4



Cockpit Padding

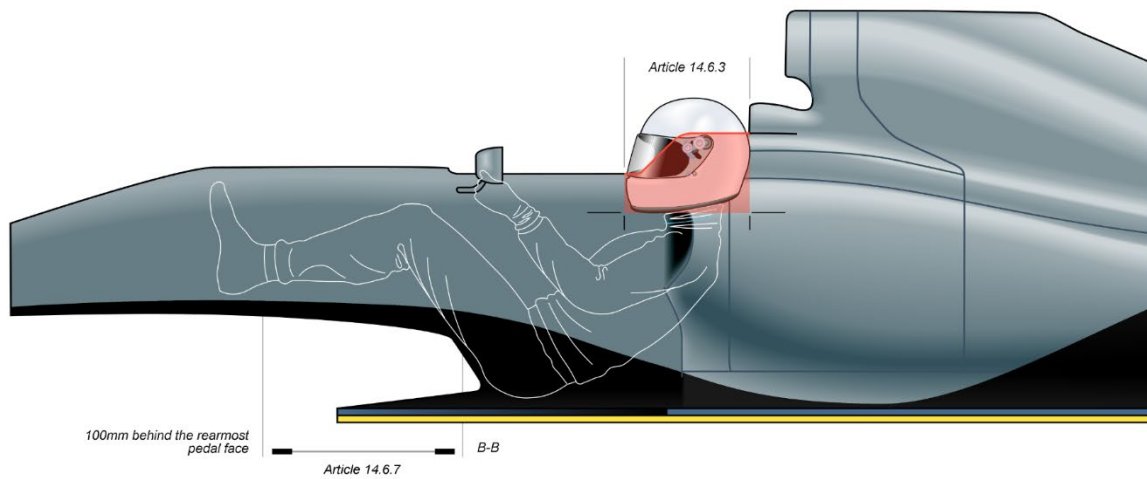

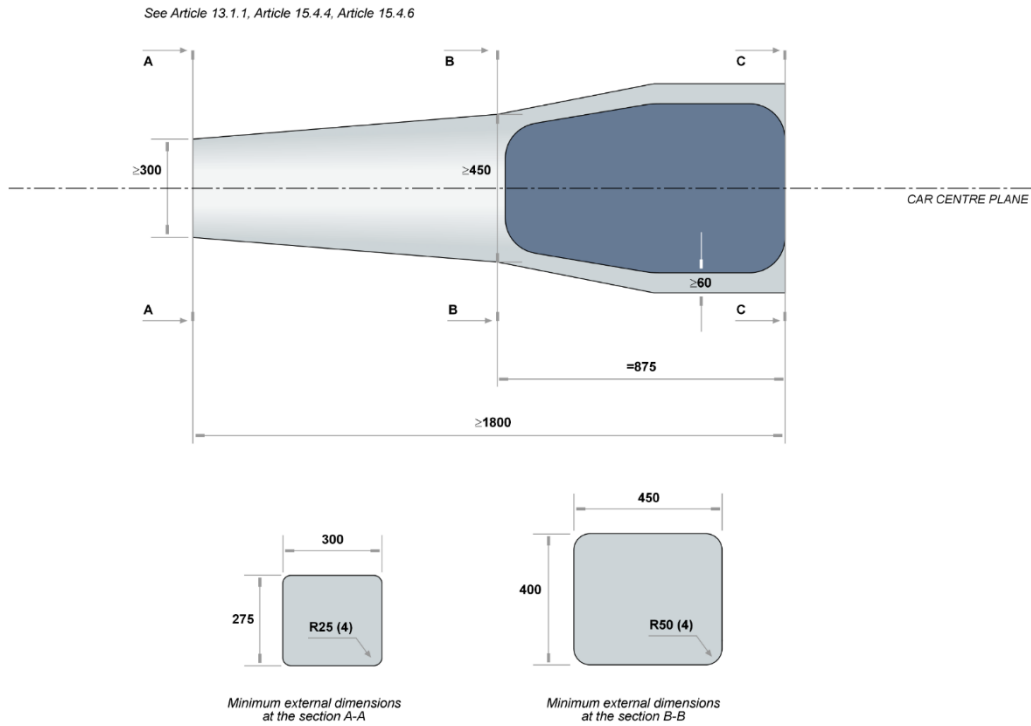

21.2 Location and fitting of camera equipment :

21.2.1 Any camera fitted in positions 2, 3 or 4 shown in Drawing 6 must be mounted in order that its major axis does not subtend an angle greater than 1° to the reference plane, and its lateral axis is normal to the car centre plane.

21.2.2 Any camera fitted in position 1 must be fitted above the survival cell, forward of the cockpit opening, rearwards of the forward attachment of the Secondary Roll Structure described in Article 15.2.3, and symmetrically with respect to the car centre plane, with the camera pointing towards the driver. The electronic conditioning unit for this camera must be positioned within the survival cell and in accordance with the Appendix to the Technical Regulations.

21.2.3 When viewed from the side of the car, the entire camera in position 2 must lie within the area formed by two vertical lines 150mm and 450mm forward of the front wheel centre line, a horizontal line 325mm above the reference plane and a diagonal line from a point on A-A and 550mm above the reference plane to a point 50mm rearward of the forward-most point of the impact absorbing structure defined in Article 15.5.8 and 220mm above the reference plane. Furthermore, the entire camera in position 2 must be mounted more than 150mm from car centre plane.

Any camera fitted in the left hand position 2 shown in Drawing 6 must be mounted in order that its major axis where passing through the centre of the camera lens does not intersect any part of the car lying forward of the camera.

Any part provided by the Competitor for the purpose of aligning the camera in positions 2 correctly will be considered part of the camera provided it does not exceed 15mm in width and is being fitted for that sole purpose.

21.2.4 The camera fitted in position 3 must be mounted in order that its forward-most point is situated between 140mm and 300mm rearward of the plane C-C and 870mm (+/-5mm) above the reference plane. The inner face of the camera unit should be between 120mm and 150mm from the car centre plane.

Any part provided by the Competitor for the purpose of aligning the camera in position 3 must be an extrusion of the camera unit profile. A radius of up to 10mm will be permitted where this component meets the bodywork or survival cell.

21.2.5 The camera fitted in position 4 must be mounted in order that its forward-most point is no more than 80mm rearward of the plane C-C.

21.2.6 The camera fitted in position 5 should be mounted parallel to the reference plane, symmetrically about the car centre plane and at least 400mm forward of the cockpit opening. In order to not impinge on its 360deg image, any shrouding or cut-out should be no higher than shoulder X, as defined in the Appendix to the Technical Regulations.

21.3 Transponders :

All cars must be fitted with two timing transponders supplied by the officially appointed timekeepers. These transponders must be fitted in strict accordance with the instructions detailed in the Appendix to the Technical Regulations. Teams must use their best endeavours to ensure that the transponders are in working order at all times.

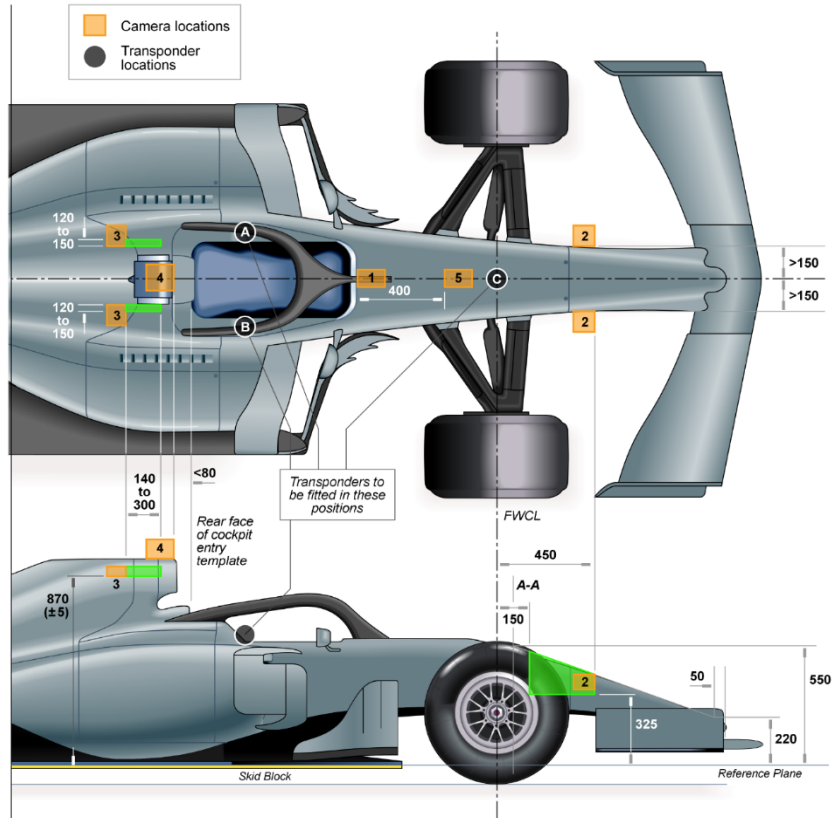

Drawing 7



Front Wing Section - Side, Front & Plan View

Tolerances are to help overcome any possible manufacturing problems, and not to permit any design which may contravene any part of these regulations

Profile co-ordinates (relative to the lower trailing edge point)

lower TE point				Tolerance on profile coordinates ±0.500mm			
x	z	x	z	x	z	x	z
0,000	0,000						
lower side				upper side			
x	z	x	z	x	z	x	z
-0,467	-0,080	-153,542	-9,818	-239,274	18,299	-142,525	32,855
-1,314	-0,217	-156,159	-9,675	-239,125	19,055	-139,816	32,468
-2,398	-0,398	-158,752	-9,425	-238,936	19,631	-137,088	32,257
-3,675	-0,605	-161,316	-9,158	-238,668	20,210	-134,342	32,021
-5,107	-0,942	-163,851	-8,884	-238,349	20,757	-131,576	31,771
-6,681	-1,097	-166,361	-8,601	-237,967	21,347	-128,757	31,487
-8,372	-1,368	-168,842	-8,303	-237,522	21,906	-126,006	31,209
-10,176	-1,658	-171,291	-7,995	-237,023	22,456	-123,197	30,897
-12,078	-1,963	-173,711	-7,678	-236,464	22,995	-120,377	30,567
-14,073	-2,280	-176,098	-7,350	-235,846	23,517	-117,546	30,217
-16,148	-2,604	-178,452	-7,017	-235,173	24,031	-114,705	29,846
-18,302	-2,939	-180,774	-6,670	-234,440	24,533	-111,854	29,458
-20,529	-3,281	-183,059	-6,318	-233,652	25,019	-108,995	29,050
-22,813	-3,630	-185,315	-5,962	-232,808	25,489	-106,130	28,621
-25,159	-3,987	-187,530	-5,590	-231,914	25,960	-103,258	28,171
-27,566	-4,344	-189,713	-5,199	-230,961	26,407	-100,384	27,702
-30,021	-4,702	-191,855	-4,813	-229,955	26,846	-97,503	27,215
-32,524	-5,064	-193,960	-4,413	-228,895	27,269	-94,623	26,709
-35,078	-5,427	-196,029	-4,008	-227,784	27,681	-91,745	26,187
-37,687	-5,787	-198,057	-3,583	-226,618	28,078	-88,864	25,645
-40,295	-6,144	-200,045	-3,174	-225,404	28,460	-85,984	25,083
-42,862	-6,499	-201,991	-2,741	-224,139	28,833	-83,109	24,505
-45,691	-6,852	-203,897	-2,303	-222,823	29,190	-80,239	23,911
-48,388	-7,198	-205,759	-1,860	-221,455	29,536	-77,379	23,302
-51,142	-7,535	-207,580	-1,404	-220,041	29,866	-74,524	22,677
-53,924	-7,866	-209,356	-9,943	-218,578	30,185	-71,677	22,037
-56,726	-8,191	-211,091	-8,476	-217,070	30,489	-68,844	21,386
-59,550	-8,503	-212,778	-8,002	-215,514	30,778	-66,023	20,720
-62,394	-8,805	-214,421	0,482	-213,911	31,053	-63,216	20,046
-65,254	-9,099	-216,014	0,974	-212,264	31,319	-60,425	19,358
-68,126	-9,375	-217,563	1,472	-210,571	31,569	-57,651	18,653
-71,014	-9,642	-219,064	1,974	-208,834	31,805	-54,897	17,961
-73,910	-9,893	-220,516	2,484	-207,050	32,025	-52,168	17,249
-76,818	-10,130	-221,919	3,003	-205,227	32,234	-49,459	16,534
-79,732	-10,352	-223,274	3,527	-203,361	32,432	-46,779	15,817
-82,650	-10,557	-224,580	4,059	-201,456	32,612	-44,127	15,095
-85,574	-10,745	-225,833	4,596	-199,507	32,780	-41,503	14,370
-88,501	-10,917	-227,034	5,141	-197,519	32,939	-38,911	13,647
-91,431	-11,073	-228,183	5,691	-195,493	33,077	-36,359	12,927
-94,360	-11,209	-229,283	6,245	-193,427	33,205	-33,843	12,210
-97,283	-11,326	-230,326	6,807	-191,322	33,319	-31,366	11,496
-100,205	-11,426	-231,317	7,374	-189,181	33,422	-28,938	10,789
-103,126	-11,507	-232,251	7,946	-187,009	33,506	-26,557	10,093
-106,037	-11,572	-233,133	8,523	-184,792	33,580	-24,223	9,404
-108,944	-11,617	-233,955	9,106	-182,546	33,639	-21,949	8,724
-111,841	-11,643	-234,723	9,697	-180,261	33,689	-19,730	8,060
-114,728	-11,650	-235,436	10,288	-177,949	33,719	-17,578	7,412
-117,606	-11,637	-236,092	10,897	-175,602	33,739	-15,493	6,781
-120,471	-11,609	-236,697	11,490	-173,224	33,741	-13,462	6,171
-123,323	-11,562	-237,226	12,093	-170,815	33,733	-11,551	5,578
-126,161	-11,496	-237,705	12,704	-168,375	33,711	-9,710	5,013
-128,986	-11,414	-238,123	13,319	-165,907	33,675	-7,963	4,474
-131,799	-11,311	-238,485	13,934	-163,408	33,624	-6,326	3,971
-134,581	-11,196	-238,781	14,572	-160,883	33,556	-4,804	3,499
-137,354	-11,058	-239,021	15,158	-158,335	33,474	-3,418	3,066
-140,106	-10,910	-239,192	15,798	-155,759	33,382	-2,162	2,682
-142,837	-10,739	-239,313	16,385	-153,156	33,289	-1,135	2,353
-145,547	-10,557	-239,356	17,134	-150,531	33,145	-0,314	2,090
-148,236	-10,357	-239,347	17,719	-147,886	33,000	0,137	1,855
-150,903	-10,143			-145,215	32,841		

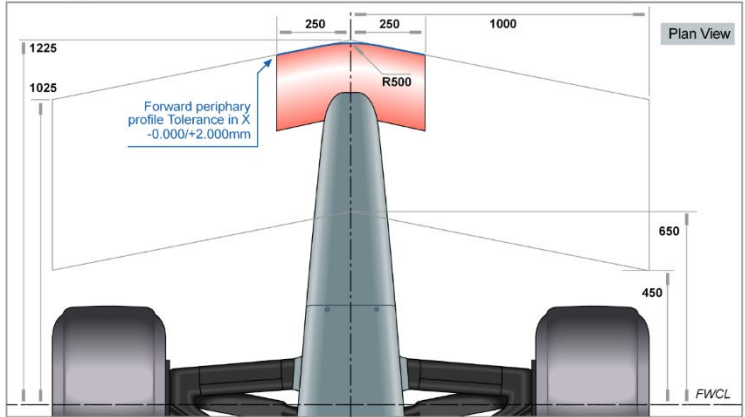
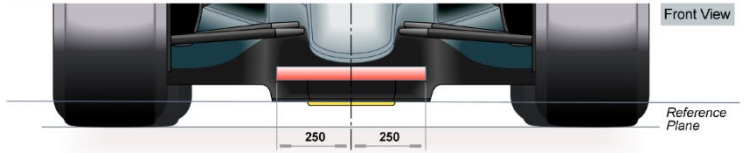
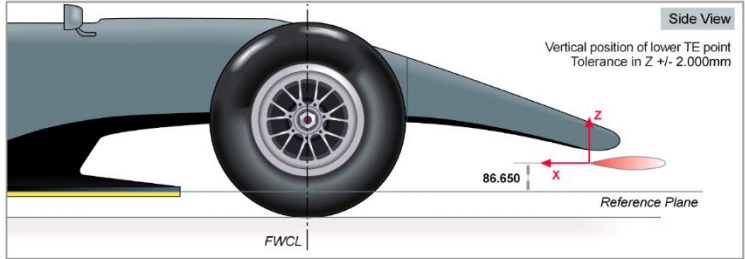

Drawing 8



Crankshaft Mass

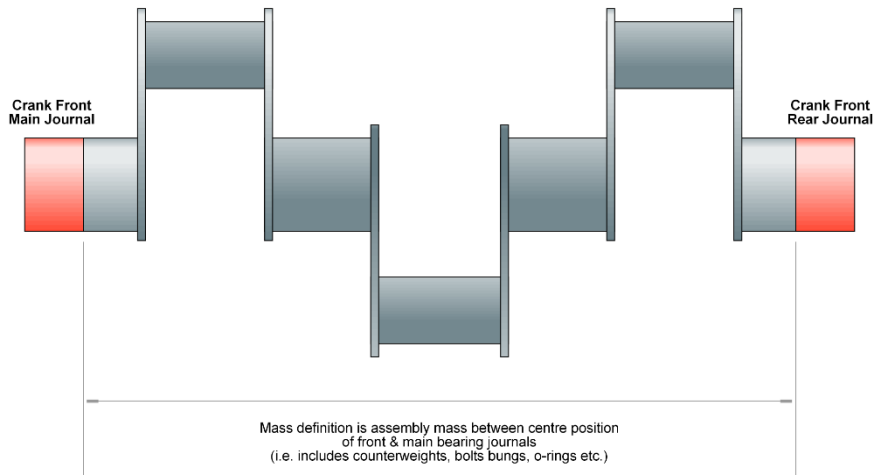

APPENDIX 2: POWER UNIT SYSTEMS, FUNCTIONS AND COMPONENTS

Item No	List of PU functions/systems/components	Art. 1.22	Art. 5.3.7	Art. 5.4.1	Art. 5.4.2	Art. 5.22	App. 4 (SR)	App. 4 - 5) & 7) (SR)
		Defin.	Legal. Box	Weight	Centre Grav.	Seal. Perim.	PU Homol.	PU Element associated
1	All Engine sub-assemblies sealed according to Article 23 of the F1 Sporting Regulations (e.g. engine components within cam-covers, cylinder heads, crankcase, any gear case)	INC	INC	INC	INC	INC	INC	ICE
2	PU pressure charging components (e.g. compressor from inlet to outlet including wheel; turbine from inlet to outlet including wheel; shaft, bearings and housings)	INC	INC	INC	INC	INC	INC	TC
3	Wastegate, Pop-off valve or similar	INC	INC	INC	INC	EXC	INC	ICE or TC or Engine Exhaust System
4	PU Engine air inlet system from Engine plenum entry to cylinder head (e.g. plenum, trumpets, throttles)	INC	INC	INC	INC	EXC	INC	ICE
5	Engine exhaust system (excluding fasteners & seals)	INC	INC	INC	EXC	INC	INC	Engine Exhaust System
6	PU mounted fuel system components: (e.g. High Pressure fuel hose, fuel rail, fuel injectors, accumulators)	INC	INC	INC	INC	EXC	INC	ICE
7	PU mounted electrical components (e.g. wiring loom within legality volume, sensors, actuators, ignition coils, alternator, spark plugs)	INC	INC	INC	INC	EXC	INC	ICE or TC or MGU-H or MGU-K or Engine Exhaust System
8	All PU coolant pumps, oil pumps, scavenge pumps, oil air separators and fuel high pressure pumps (delivering more than 10barG) including any of the following associated components: motors, actuators, filters, brackets, supports, screws, nuts, dowels, washers, cables, oil or air seals. All tubes or hoses between components of the PU that are not described by line 28. Excludes hydraulic pumps and ERS parts described in line 9.	INC	INC	INC	INC	EXC	INC	ICE

Item No	List of PU functions/systems/components	Art. 1.22	Art. 5.3.7	Art. 5.4.1	Art. 5.4.2	Art. 5.22	App. 4 (SR)	App. 4 - 5) & 7) (SR)
		Defin.	Legal. Box	Weight	Centre Grav.	Seal. Perim.	PU Homol.	PU Element associated
9	Cooling pumps (and associated motors, actuators, associated filters, brackets, support, screws, nuts, dowels, washers, cables, tubes, hoses, oil or air seals) partly or wholly for ERS components not mandatorily included in the PU legality volume.	INC	EXC	INC	EXC	EXC	INC	ICE or ES or MGU-H or MGU-K or CE
10	Main PU oil tank, catch tanks, and any breather system connected to the PU and associated filters, brackets, support, screws, nuts, dowels, washers, cables, tubes, hoses, oil or air seals, with the exception of parts described in line 11.	INC	INC	INC	INC	EXC	INC	ICE
11	Any breather system ducting between the PU and the orifice referenced in Article 5.1.13.	EXC	EXC	EXC	EXC	EXC	EXC	-
12	MGU-K excluding mechanical power transmission components and mounting accessories	INC	INC	INC	INC	INC	INC	MGU-K
13	MGU-K mechanical power transmission components and mounting accessories	INC	INC	INC	INC	EXC	INC	ICE or MGU-K
14	MGU-H excluding mechanical power transmission components and mounting accessories.	INC	INC	INC	INC	INC	INC	MGU-H
15	MGU-H mechanical power transmission components and mounting accessories	INC	INC	INC	INC	EXC	INC	TC or MGU-H
16	ES parts defined in Article 5.4.3	INC	EXC	EXC	EXC	INC	INC	ES
17	ES excluding parts defined in Article 5.4.3	INC	EXC	EXC	EXC	EXC	INC	ES
18	Wiring between any ECU and phases of MGU-K	INC	EXC	INC	EXC	EXC	INC	MGU-K or CE
19	Wiring between any ECU and phases of MGU-H	INC	EXC	INC	EXC	EXC	INC	MGU-H or CE
20	Wiring between any ECU and ES	INC	EXC	INC	EXC	EXC	INC	ES or CE
21	PU-CE excluding associated brackets, supports, screws, nuts, dowels, washers or cables.	INC	EXC	INC	EXC	INC	INC	CE
22	Brackets, supports, screws, nuts, dowels, washers or cables associated to the parts listed in line 21.	INC	EXC	INC	EXC	EXC	INC	CE

Item No	List of PU functions/systems/components	Art. 1.22	Art. 5.3.7	Art. 5.4.1	Art. 5.4.2	Art. 5.22	App. 4 (SR)	App. 4 - 5) & 7) (SR)
		Defin.	Legal. Box	Weight	Centre Grav.	Seal. Perim.	PU Homol.	PU Element associated
23	FIA Standard ECU.	INC	EXC	EXC	EXC	EXC	INC	-
24	Any actuators needed to make the PU function at all times. (except specific exclusions)	INC	INC	INC	INC	EXC	INC	ICE or TC or ES or Engine Exhaust System
25	Intake upstream of compressor inlet up to and including the air filter.	EXC	EXC	EXC	EXC	EXC	EXC	-
26	Heat Shields and associated mounting hardware.	EXC	EXC	EXC	EXC	EXC	EXC	-
27	Water system accumulators	EXC	EXC	EXC	EXC	EXC	EXC	-
28	Heat exchangers and their associated accessories. (including but not limited to housings, tubes, pipes, hoses, supports, brackets and fasteners)	EXC	EXC	EXC	EXC	EXC	EXC	-
29	Hydraulic system (e.g. pumps, accumulators, manifolds, servo-valves, solenoids, actuators) other than servo valve(s) and actuator(s) for PU control.	EXC	EXC	EXC	EXC	EXC	EXC	-
30	Hydraulic system servo valve(s) and actuator(s) for PU control.	INC	INC	INC	INC	EXC	INC	ICE or TC or Engine Exhaust System
31	Fuel feed pumps delivering less than 10 barG and their associated accessories (included but not limited to tubes, hoses, supports, brackets and fasteners).	EXC	EXC	EXC	EXC	EXC	EXC	-
32	Any ancillary equipment associated with the PU air valve system such as regulators or compressors.	INC	EXC	EXC	EXC	EXC	INC	ICE
33	Exhaust beyond turbine exit and WG exit and associated brackets, support, screws, nuts, dowels, washers or cables.	EXC	EXC	EXC	EXC	EXC	EXC	-
34	Studs used to mount PU to chassis or gearbox.	EXC	EXC	EXC	EXC	EXC	EXC	-
35	Flywheel	INC	EXC	EXC	EXC	EXC	EXC	-
36	Clutch and clutch actuation system between the PU and the gearbox	EXC	EXC	EXC	EXC	EXC	EXC	-
37	Fuel	EXC	EXC	EXC	EXC	EXC	INC	Fuel
38	Engine oil	EXC	EXC	EXC	EXC	EXC	INC	Engine Oil
39	Liquids other than Fuel and Engine oil.	EXC	EXC	EXC	EXC	EXC	EXC	-

Item No	List of PU functions/systems/components	Art. 1.22	Art. 5.3.7	Art. 5.4.1	Art. 5.4.2	Art. 5.22	App. 4 (SR)	App. 4 - 5) & 7) (SR)
		Defin.	Legal. Box	Weight	Centre Grav.	Seal. Perim.	PU Homol.	PU Element associated
40	Ballast mounted on the PU up to 2kg. This is permitted (subject to Article 4.4) but any in excess of 2kg will be removed before measuring PU weight.	INC	INC	INC	INC	EXC	EXC	-
41	Ballast mounted on the PU in excess of 2kg.	EXC	EXC	EXC	EXC	EXC	EXC	-
42	Wiring harnesses which are not ordinarily part of a power unit.	EXC	EXC	EXC	EXC	EXC	EXC	-

If more than one PU Element is listed in the last column of the above table, the PU Manufacturer will have to specify for any item for which it wishes to modify the specification which PU Element it belongs to in the updated homologation dossier. It is not mandatory that it be associated with the same PU Element for every change of specification.

For items in rows 7, 24 & 30 above, an independent change of specification as per the table below will be permitted for each individual component directly affected.

Maximum permitted number of specifications per PU Element and per Season	2020	2021	2022	2023 / Year N-3	Year N-2	Year N-1
Engine (ICE)	0	1	1	1	0	0
Turbocharger (TC)	0	1	1	1	0	0
Motor Generator Unit – Heat (MGU-H)	0	1	1	1	0	0
Motor Generator Unit – Kinetic (MGU-K)		1		1	0	0
Energy Store (ES)		1		1	0	0
Control Electronics (CE)*		1		1	0	0
Engine Exhaust System	0	1	1	1	0	0
Fuel	0	1	1	1	1	0
Engine Oil	0	1	1	1	1	0

* above limits apply separately to each individual Control Electronics unit.

n : Championship season on which new PU regulations will come into force.

0: In 2020, it means that first race specification must be kept during the complete season. From 2021 onwards it means the previous season's specification

1: In 2020 it means that 1 specification update is possible during the season. From 2021 onwards, it means that 1 specification update is possible between end of previous season and end of current season.

APPENDIX 3: POWER UNIT ENERGY FLOW

POWER UNIT ENERGY FLOW
Legend: Engine - ERS - Other

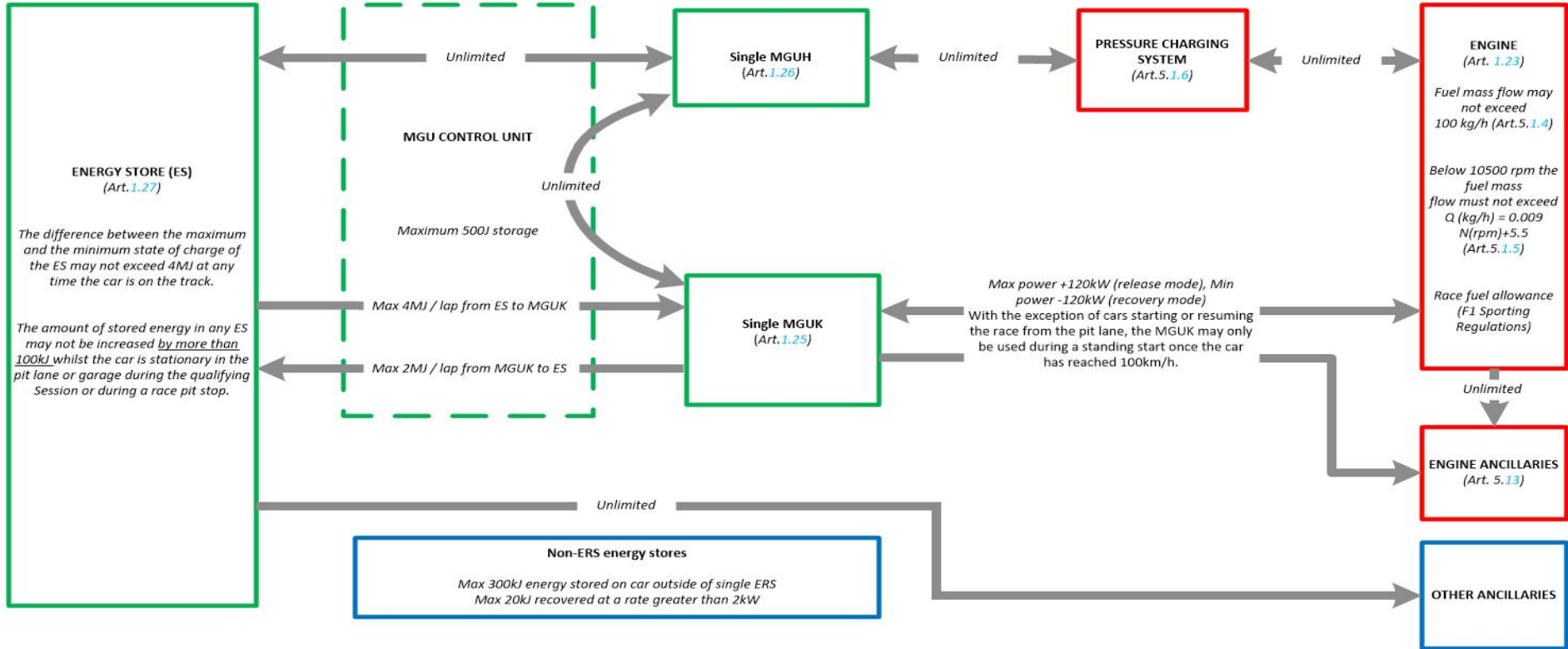

Control of Energy Management:
 -One sensor is connected to measure all electrical energy into and out of the Energy Store.
 -One Sensor is connected to measure all electrical energy into and out of the MGU-K.
 -The DC-DC convertor may only consume energy. This will be verified by inspection.

Issue 07 - 30/04/2020

APPENDIX 4: COMPONENTS' CLASSIFICATION, HOMOLOGATION STATUS AND PERIMETER

The following table defines the classification and homologation status, freeze date and tokens, of components for Formula One cars and support equipment in respect of the 2021 Championship.

In the case where a component's homologation requirements are covered by another Article or Appendix of the Technical or Sporting Regulations, those will still apply, regardless of the presence or not of this component in the list below. Should there be any contradiction or any issues related to the perimeter of the homologated component the Competitor should contact the FIA for guidance.

The table also defines the perimeter of the homologated (HC), transferable (TRC) or transitional carry-over (TCO) components and, where applicable, their sub-assemblies, for the purposes of determining homologation perimeter, the Notional Values, or to be used for TCO allowances, as defined in the Financial Regulations.

In the cases where there is doubt on the inclusion of not of a component in an assembly, or in the exact boundary between two sub-assemblies of the same component or assembly, the Competitor should approach the FIA for guidance.

Ref	Component name	Reg. Article	Class.	Freeze Date	Notes & Permitted (token-free) minimal exceptions	Tokens	TCO	System Description & Boundaries	Included Components (List not exhaustive)	Excluded Components and notes
1	Survival Cell Items & Safety Structures									
1A	Survival Cell / forward of B-B		LTC-H	R1-2020		2	Y	The structure that includes the cockpit, takes suspension loads and aerodynamic loads and transfers them from and to the FIS through the FIS fixings and power unit through the engine studs	Bonded component as submitted for homologation.	Any additional bonded components not required for FIA tests, any components fitted for FIA tests that are then subsequently removed
1B	Survival Cell / behind B-B		LTC-H	R1-2020		2	Y			
1C	Primary Roll Structure		LTC-H	R1-2020		2	Y	Roll structure as defined in A15.2		Fairings, ducts

Ref	Component name	Reg. Article	Class.	Freeze Date	Notes & Permitted (token-free) minimal exceptions	Tokens	TCO	System Description & Boundaries	Included Components (List not exhaustive)	Excluded Components and notes
1D	Front Floor Structure		FSC-H	R1-2020	modifications for wheelbase changes	1	Y	Front floor assembly	Front floor structure, mounting brackets and any stay or structure between the front of the bodywork lying on the reference plane and the survival cell.	Fixings to the survival cell, fairings.
1G	Front Impact structure		LTC-H	mid-2020	changes to fairings not deemed to affect impact	2	Y	The structure that takes aerodynamic loads from the front wing and transfers them to the chassis	FIS, hangers, fixings to chassis that are part of the FIS assembly	Fairings, Camera brackets
1H	Rear Impact structure (for 2020 and 2021 NOT including transition to Gearbox)		FSC-H	R1-2020		2	Y	The structure that mounts to the rear of the gearbox behind the differential	Part as bonded to gearbox carrier	Fairings, bolted components
1J	Any component inside the survival cell, unless otherwise specified (e.g. fire extinguisher)		FSC-H	R1-2020	changes for driver fit	1 each				
1K	Pedals		FSC-H	R1-2020	changes for driver fit	1	Y	Pedal Assembly	Brake pedal assembly including throttle Pedal including throttle damper, heel-rest, mounting brackets and local electrical and electronic components	Fixings to the survival cell.

Ref	Component name	Reg. Article	Class.	Freeze Date	Notes & Permitted (token-free) minimal exceptions	Tokens	TCO	System Description & Boundaries	Included Components (List not exhaustive)	Excluded Components and notes
2 Aerodynamic components										
2A	Aerodynamic components, unless otherwise specified	3	LTC							
2B	Plank assembly	3.7.11, 3.7.12, 3.7.13	LTC-H	mid-2020	modifications for wheelbase changes 2 Options may be homologated and combined	1		Plank assembly as defined in A3.7.11, A3.7.12 of the 2021 TR	Plank structure and skids	
2C	Rear wing adjuster (DRS)	3.5.8	LTC-H	mid-2020	-possible to homologate 2 options for different levels of downforce -linkages to achieve different kinematic characteristics are allowed	1	Y	DRS actuator including linkages	Machined DRS Actuators, linkages, local electrical and electronic components	Hoses, any component rigidly attached to the rear wing flap.
2D	Air ducts	11.4-11.6	LTC							
3 Transmission										

Ref	Component name	Reg. Article	Class.	Freeze Date	Notes & Permitted (token-free) minimal exceptions	Tokens	TCO	System Description & Boundaries	Included Components (List not exhaustive)	Excluded Components and notes
3A	Gearbox Carrier (for 2020 and 2021, includes the transition between gearbox and RIS crushable part)	9.5	TRC-H	R1-2020		2	Y	The structure that supports the Cassette, mounts the rear impact structure, takes suspension loads and aerodynamic loads and transfers them to the power unit through the engine studs.	Gearbox carrier, associated fastenings, internal heat shields	RIS, Inboard suspension components, Engine mountings
3B	Gearbox Cassette	9.5	TRC-H	R1-2020			Y	The housing that immediately encloses the Driveline Components and Gear-Change Components including all associated covers, integrated or not to the Gearbox carrier.	Cassette, Front Cover, Diff Cap, Seals, Fasteners, Cross-shaft Covers	
3C	Clutch	9.2	TRC-H	R1-2020		1	Y	Rotating clutch assembly and fixings to PU or Gearbox as appropriate.	Clutch basket assembly, Plates, Spring, fixings to PU or Gearbox, Spigot bearing	
3D	Clutch actuation system	9.2	TRC-H	R1-2020		1	Y	Clutch actuator assembly including sensors and cooling shroud and sensors	Clutch Actuator, Actuator support, local electrical and electronic components, Fixings to PU or Gearbox, Cooling Shroud.	Servo Valves
3E	Clutch shaft	9.2	TRC-H	R1-2020		1	Y	Shaft between clutch and gearbox (if PU mounted) or PU (if Gearbox mounted)	Clutch shaft, intermediate support bearing and bracket if required.	Clutch shaft torque sensor
3F	Clutch shaft torque sensor	9.2	FSC-H	R1-2020		1	Y			

Ref	Component name	Reg. Article	Class.	Freeze Date	Notes & Permitted (token-free) minimal exceptions	Tokens	TCO	System Description & Boundaries	Included Components (List not exhaustive)	Excluded Components and notes
3G	Driveline Components (Shafts, bearings, gears except ratio pairs)	9.5	TRC-H	R1-2020	The differential may be rotated around the cross-shaft	2	Y	The rotating components involved in transmitting torque between the gearbox input shaft and the drive shafts.	Shafts and associated bearings, Gear Ratio pairs, Dog Rings, Bevel Gears, Cross shaft, Differential and rotating parts of differential control mechanism.	Servo valves
3H	Gear Ratios	9.6	TRC-H	R1-2021		n/a	Y	Forward Ratio Pairs		
3J	Gear change Components (actuators, barrels, forks, sensors etc.)	9.5	TRC-H	R1-2020		2	Y	Mechanical components that are involved in selecting the forward gears.	Barrel(s) and associated bearings, Selector Forks, Selector Rail, Detent Mechanisms, Hydraulic Actuator(s), local electrical and electronic components	
3K	Auxiliary Components (Oil system, reverse gear etc.)	9.5	TRC-H	R1-2020	Hoses	1	Y	Components that are not included in Driveline or Gear-Change Components but interact directly with these components and are essential for the functioning of the gearbox.	Oil Pressure and Scavenge Pumps, Oil Filter, Oil Tank, Reverse-gear idler & Actuator, Differential Actuator, local electrical and electronic components.	Oil cooler
3L	Drive shaft		FSC-H	R1-2021		n/a		The assembly that transfers load from the gearbox driveline components to the Axles	Driveshaft, joints, bearings and any required fixings, torque sensors and/or trigger wheels if present	
4	Suspension and steering									

Ref	Component name	Reg. Article	Class.	Freeze Date	Notes & Permitted (token-free) minimal exceptions	Tokens	TCO	System Description & Boundaries	Included Components (List not exhaustive)	Excluded Components and notes
4A	Inboard Front Suspension		TRC-H	mid-2020	Spring elements & damper internals may be changed, and more options may be available	2	Y	All parts of the front suspension between the connection to the push / pull rod and the survival cell.	Rockers, springs, ARB system, dampers, inerters, bearings, local electrical and electronic components, ride height adjustment, any brackets which are not integral with the survival cell. A range of set-up options	
4B	Front Suspension Members		TRC-H	R1-2021	+1 version to be used only in Monaco 2021 Changes to brackets or spacers for setup changes are permitted.	n/a	Y	Structural members connecting the upright to the survival cell, steering or inboard suspension	Wishbones / Links, Track-rod, Push/pull Rod, Bearings, Inboard Brackets not integrated in the survival cell, Fasteners, Wheel Tethers, local electrical and electronic components	
4C	Front Upright Assembly (Excluding Axles, bearings, nuts & retention system)		TRC-H	R1-2021	Changes to brackets or spacers for setup changes are permitted.	n/a	Y	Upright assembly between the connection to the suspension members and the wheel bearings	Upright, Brackets - including variants for set-up changes, Fasteners, local electrical and electronic components, Upright Loom.	Any braking system components described in Article 11
4D	Front Axles (Inboard of the contact surface with the wheel spacer) and bearings,		FSC-H	R1-2020		1	Y	Axle geometry lying inboard of the contact surface with the wheel spacers and wheel bearing assembly	Axle geometry lying inboard of the contact surface with the wheel spacers, wheel bearings and spacers, interface and mounting to the brake disc bell,	

Ref	Component name	Reg. Article	Class.	Freeze Date	Notes & Permitted (token-free) minimal exceptions	Tokens	TCO	System Description & Boundaries	Included Components (List not exhaustive)	Excluded Components and notes
	Front Axles (outboard of the contact surface with the wheel spacer), nuts & retention system							Axle geometry lying outboard of the contact surface with the wheel spacers, wheel nut and dual stage mechanism to retain nut if loose	Axle geometry lying outboard of the contact surface with the wheel spacers, axle nuts, wheel nut, fasteners and wheel nut retention	
4E	Front Suspension Fairings		TRC			n/a	Y		Fairings attached to structural suspension members	(2021 Only)
4F	Inboard Rear Suspension		TRC-H	mid-2020	spring elements & damper internals may be changed, and more options may be available	2	Y	All parts of the rear suspension between the connection to the push / pull rod and the gearbox carrier	Rockers, springs, ARB system, dampers, inerters, hydro-gas spring systems, bearings, local electrical and electronic components, ride height adjustment, any brackets which are not integral with the Gearbox Carrier. A range of set-up options	
4G	Rear Suspension Members		TRC-H	R1-2021	Changes to brackets or spacers for setup changes are permitted.	n/a	Y	Structural members connecting the upright to the gearbox case or inboard suspension	Wishbones / Links, Track-rod, Push/pull Rod, Bearings, Inboard Brackets not integrated in the Gearbox Carrier, Fasteners, Wheel Tethers, local electrical and electronic components.	
4H	Rear Upright Assembly (Excluding Axles, bearings, nuts & retention system)		TRC-H	R1-2021	Changes to brackets or spacers for setup changes are permitted.	n/a	Y	Upright assembly between the connection to the suspension members and the wheel bearings	Upright, Brackets - including variants for set-up changes, Fasteners, local electrical and electronic components.	Any braking system components described in Article 11

Ref	Component name	Reg. Article	Class.	Freeze Date	Notes & Permitted (token-free) minimal exceptions	Tokens	TCO	System Description & Boundaries	Included Components (List not exhaustive)	Excluded Components and notes
4J	Rear Axles (Inboard of the contact surface with the wheel spacer) and bearings,		FSC-H	R1-2020		1	Y	Axle geometry lying inboard of the contact surface with the wheel spacers and wheel bearing assembly	Axle geometry lying inboard of the contact surface with the wheel spacers, wheel bearings and spacers, interface and mounting to the brake disc bell,	
	Rear Axles (outboard of the contact surface with the wheel spacer), nuts & retention system							Axle geometry lying outboard of the contact surface with the wheel spacers, wheel nut and dual stage mechanism to retain nut if loose	Axle geometry lying outboard of the contact surface with the wheel spacers, axle nuts, wheel nut, fasteners and wheel nut retention	
4K	Rear Suspension Fairings		TRC			n/a	Y		Fairings attached to structural suspension members	(2021 Only)
4L	Power Assisted Steering		TRC-H	R1-2021	2 options may be available, setup changes are permitted	n/a	Y	Steering unit from the attachment to the steering column to the clevises for the track rods, connection to the hydraulic system and connection to the electrical loom	Rack assembly, local electrical and electronic components, protective cover, fasteners to survival cell, options for varying assistance.	
4M	Steering column		FSC-H	R1-2021	changes for driver fit	n/a	Y	The assembly that transfers load from the steering wheel QD through to the Power Assisted Steering	Forward and Rearward columns, bearings, mounting brackets, attachments to chassis, parts required to pass impact test. local electrical and electronic components.	Fixings to the survival cell.

Ref	Component name	Reg. Article	Class.	Freeze Date	Notes & Permitted (token-free) minimal exceptions	Tokens	TCO	System Description & Boundaries	Included Components (List not exhaustive)	Excluded Components and notes
4N	Steering wheel and quick release		FSC-H	R1-2021	Two specifications may be homologated. Changes for driver fit	n/a	Y	The assembly that transfers load from the driver to the steering column	Steering Wheel, quick release mechanism, gear shift and clutch paddles, local electrical and electronic components, SECU elements integrated in the assembly	Any component that cannot be removed via the operation of the quick release
4P	Wheel rims		FSC-H	R1-2020	Single specification only allowed in 2021	2	Y	Wheel Rim Assembly	Rim, drive pegs, spacers, valve	TPMS sensor
4Q	Tyre pressure sensor (TPMS)		FSC-H	R1-2020		1				
4R	Tyres		SSC							
4S	Tyre Blankets and control boxes		FSC-H	R1-2020						
5	Brakes									
5A	Brake disc, disk bell and pad assembly		FSC-H	mid-2020	changes permitted for change of supplier 3 assembly options may be used per axle	1			Structural brake disk bell transferring torque from the axle to the brake disc, brake disk and pads	Any component bolted on the structural disk bell (i.e. deflectors) pads
5B	Brake calipers		FSC-H	R1-2020		1 each	Y		Machined Brake Calipers, pistons, seals, QD's, local electrical and electronic components	Hoses, pipes and mounting system to the uprights.

Ref	Component name	Reg. Article	Class.	Freeze Date	Notes & Permitted (token-free) minimal exceptions	Tokens	TCO	System Description & Boundaries	Included Components (List not exhaustive)	Excluded Components and notes
5C	Rear brake control system (BBW)		FSC-H	R1-2020		1 each	Y		BBW master cylinder and actuator, servo or solenoid valves, directly mounted local electrical and electronic components master cylinders, balance bar assembly	Hoses and pipes
5D	Brake master cylinder		FSC-H	R1-2020		1	Y		Master cylinder(s), push-rods, brake balance system, local electrical and electronic components	Fixings to the survival cell.
6	Fuel system									
6A	Collector	6	FSC-H	R1-2020		1	Y		Collector assembly including any local electrical and electronic components, filters, AV mounts and mounting fasteners	Hoses and pipes
6B	Primer pumps, damper, pipes	6	FSC-H	R1-2020		1	Y	Primer pump and pipes between pump and breakaway valve.	Primer pump, pipes between pump and breakaway valve, fittings between pump and breakaway valve.	Components classified as part of collector. Components upstream of pump.
6C	Fuel Bag	6	FSC-H	R1-2020		1		Fuel bag to contain fuel within the survival cell	Flap-Valves, fuel bag fittings, fuel bag hatches	
6D	Fuel system components not listed as FSC or SSC - but NOT external fuel bag	6	FSC-H	R1-2020		1	Y	Lift pumps, hoses, filters upstream of collector	All lift pumps, hoses, filters upstream of collector, electrical looms, PRVs, NRVs	
7	Hydraulic System									

Ref	Component name	Reg. Article	Class.	Freeze Date	Notes & Permitted (token-free) minimal exceptions	Tokens	TCO	System Description & Boundaries	Included Components (List not exhaustive)	Excluded Components and notes
7A	Hydraulic pump and accumulator		TRC-H	R1-2020		1	Y		Hydraulic pump, hydraulic accumulator, local electrical and electronic components, parts required to mount the unit to the PU	
7B	Hydraulic manifold, sensors & control valves		TRC-H	R1-2020		1	Y		Hydraulic manifold block, servo valves, solenoid valves, filters, local electrical and electronic components, AV mounts.	
7C	Pipes between hydraulic pump, hydraulic manifold & gearbox or engine actuators		TRC						Pipes, fittings, QD connectors.	Pipes to/from cooler, pipes to/from actuators not associated with gearbox, PU (BBW, PAS etc).
8	Engine Systems									
8A	Auxiliary oil tank		FSC-H	R1-2020		1				
9	Oil & Coolant Systems									
9A	Engine-mounted Y=0 Water-cooled charge air cooler	7	TRC-H	R1-2021		n/a	Y	System between Compressor Outlet and Plenum Inlet.	Heat exchanger, ducting from the compressor to the heat exchanger, Ducting from the heat exchanger to the plenums, directly mounted electrical and electronic components	

Ref	Component name	Reg. Article	Class.	Freeze Date	Notes & Permitted (token-free) minimal exceptions	Tokens	TCO	System Description & Boundaries	Included Components (List not exhaustive)	Excluded Components and notes
9B	Engine-mounted Y=0 Air-cooled charge air cooler	7	LTC-H	R1-2021		n/a	Y	System between Compressor Outlet and Plenum Inlet.	Heat exchanger, ducting from the compressor to the heat exchanger, ducting from the heat exchanger to the plenums, directly mounted electrical and electronic components	Ducts feeding cooling air.
9C	All other air-cooled coolers	7	LTC-H	R1-2021	2 specs allowed provided they are of the same fundamental technology and to cover different climatic conditions	n/a	Y	Cooler assembly excluding piping	Welded cooler, electrical and electronic components directly fitted to cooler	Fittings, hoses, pipes, AV mounts
9D	All water-oil or water-water coolers	7	FSC-H	R1-2020	Minor sizing differences due to PU heat rejection compatibility	2	Y	Cooler assembly excluding piping	Welded cooler, electrical and electronic components directly fitted to cooler	Fittings, hoses, pipes, AV mounts
					Complete removal is acceptable.					
10 Power Unit ancillaries and sensors										
10A	ERS DC sensor		SSC							
10B	Fuel Flow Meter	5.10.3	SSC				Y	Prescribed fuel flow meters		Fittings, hoses, pipes, AV mounts
10C	Power Unit Pressure and Temperature sensors	5.10.4	SSC							
		5.13.2								
		5.13.3								

Ref	Component name	Reg. Article	Class.	Freeze Date	Notes & Permitted (token-free) minimal exceptions	Tokens	TCO	System Description & Boundaries	Included Components (List not exhaustive)	Excluded Components and notes
10D	Power Unit mountings to gearbox and survival cell	5.3.8	TRC				Y	Studs between PU and Survival Cell and between PU and Gearbox.	Studs, Nuts, Top-hat Bushes, Barrel nuts.	Inserts integrated into survival cell or gearbox carrier
11 Electrical systems hardware										
11A	Mandated Electrical Components	8.2.1	SSC				Y		Elements of the SECU unless already included in another assembly, rear lights (RIS and end plate), ERS status lights, medical light, 2 x Triax	In-ear accelerometers, biometric glove, components or services that are leased are not included (SDR, HSC, F1MS, SCS), FFM, LVDT interface unit
11B	Electrical looms With the exception of test installations linked to Article 8.11.1		TRC-H	mid-2020	incidental changes affected by other components	2	Y	Looms interfacing the main chassis electrical system with PU systems, transmission systems and other peripheral control or measurement systems.	Main chassis looms, can be made of separate parts, up to and including the connectors to local PU looms, transmission looms or other local looms for peripheral control or measurement systems.	
11C	car to team telemetry	8.5.1	SSC							
11D	Driver radio	8.7	FSC-H	R1-2020		2				
11E	Accident Data Recorder (ADR)	8.8	SSC							
11F	High speed camera	SR	SSC							
11G	In-ear accelerometers	SR	SSC							
11H	Biometric gloves	SR	SSC							

Ref	Component name	Reg. Article	Class.	Freeze Date	Notes & Permitted (token-free) minimal exceptions	Tokens	TCO	System Description & Boundaries	Included Components (List not exhaustive)	Excluded Components and notes
11J	Marshalling system	SR	SSC							
11K	Timing Transponders	21.3	SSC							
11L	TV Cameras	21	SSC							
11P	Additional logging components (logging units, sensor nodes) With the exception of test installations linked to Article 8.11.1		FSC-H	mid-2020	incidental changes affected by other components	1 each				
11Q	Electrical and electronic components, unless otherwise specified With the exception of test installations linked to Article 8.11.1		FSC-H	mid-2020	incidental changes affected by other components	1 each				
12 Safety Equipment										
12A	Fire Extinguishers		FSC-H	R1-2020		1				Pipes, hoses, mountings to the survival cell.
12B	Rear lights		SSC							

Ref	Component name	Reg. Article	Class.	Freeze Date	Notes & Permitted (token-free) minimal exceptions	Tokens	TCO	System Description & Boundaries	Included Components (List not exhaustive)	Excluded Components and notes
12C	ERS status lights	5.12.3	SSC							
13	Miscellaneous components									
13A	Water drink system		FSC-H	R1-2020		1				Pipes, hoses, mountings to the survival cell.
14	Track Equipment									
14A	Pit stop equipment (guns, F&R jack, gantry & electronics)		FSC-H	mid-2020	adjustments permitted for setup reasons	1			Wheel Guns, F&R jacks, gantry and electronics	

APPENDIX 5: TERMS AND CONDITIONS FOR THE USE OF THE FIA SERVER

NOTE:

In order to protect the intellectual property rights and liability position of teams (and the FIA) that are responsible for supplying OSC design specifications (and uploading the same to the FIA's server), the FIA is preparing terms and conditions applicable to the FIA's designated server that will be included in this Appendix 5 to the Technical Regulations, and will share a draft with the teams in due course.

These terms and conditions will apply to all access to, and/or use of, any information made available through the server, including any Design Specifications made available by either the FIA or a supplying team in the case of OSCs. As a condition of accessing the relevant Design Specification, a team (or any individual acting on behalf of that team) will be required to expressly agree to the terms by opting 'Yes' in the tick box to the terms. The terms and conditions will therefore apply every time that a team access and/or uses any Design Specification. The terms and conditions will include an express waiver by any team that accesses and/or uses a Design Specification of any claims for loss or damages in respect of any use of, or reliance on, any component specification, and any liability in connection with the same will be disclaimed and released accordingly (to the extent permitted by applicable law). In addition, the terms will provide that no other team (i.e. a non-supplying team) will acquire any right, title or interest to any Design Specification (or any intellectual property right relating to any Design Specification) by virtue of accessing and/or using any such Design Specification.